

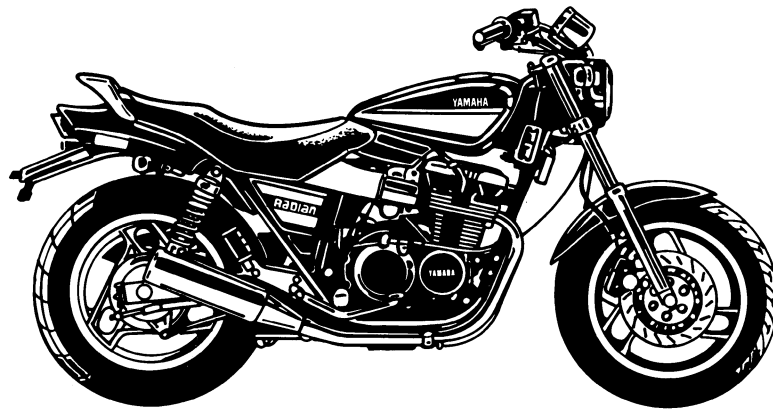

YX600 (S-A)



Service Manual

LIT-11616-06-16

NOTICE

This manual was written by the Yamaha Motor Company primarily for use by Yamaha dealers and their qualified mechanics. It is not possible to put an entire mechanic's education into one manual, so it is assumed that persons using this book to perform maintenance and repairs on Yamaha motorcycles have a basic understanding of the mechanical concepts and procedures inherent in motorcycle repair technology. Without such knowledge, attempted repairs or service to this model may render it unfit to use and/or unsafe.

Yamaha Motor Company, Ltd. is continually striving to improve all models manufactured by Yamaha. Modifications and significant changes in specifications or procedures will be forwarded to all Authorized Yamaha dealers and will, where applicable, appear in future editions of this manual.

**TECHNICAL PUBLICATIONS
SERVICE DIVISION
MOTORCYCLE OPERATIONS
YAMAHA MOTOR CO., LTD.**

HOW TO USE THIS MANUAL

PARTICULARLY IMPORTANT INFORMATION

This material is distinguished by the following notation.

NOTE: A NOTE provides key information to make procedures easier or clearer.

CAUTION: A CAUTION indicates special procedures that must be followed to avoid damage to the motorcycle.

WARNING: A WARNING indicates special procedures that must be followed to avoid injury to a motorcycle operator or person inspecting or repairing the motorcycle.

MANUAL FORMAT

















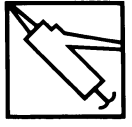

All of the procedures in this manual are organized in a sequential, step-by-step format. The information has been compiled to provide the mechanic with an easy to read, handy reference that contains comprehensive explanations of all disassembly, repair, assembly, and inspection operations.

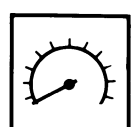
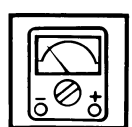
In this revised format, the condition of a faulty component will precede an arrow symbol and the course of action required will follow the symbol, e.g.,

- Bearings
Pitting/Damage → Replace.

EXPLODED DIAGRAM

Each chapter provides exploded diagrams before each disassembly section for ease in identifying correct disassembly and assembly procedures.

<p>①</p> <p>GEN INFO </p>	<p>②</p> <p>INSP ADJ </p>	
<p>③</p> <p>ENG </p>	<p>④</p> <p>COOL </p>	
<p>⑤</p> <p>CARB </p>	<p>⑥</p> <p>CHAS </p>	
<p>⑦</p> <p>ELEC </p>	<p>⑧</p> <p>APPX </p>	
<p>⑨</p> 	<p>⑩</p> 	
<p>⑪</p> 	<p>⑫</p> 	
<p>⑬</p> 	<p>⑭</p> 	
<p>⑮</p> 	<p>⑯</p> 	<p>⑰</p> 
<p>⑱</p> 	<p>⑲</p> 	<p>⑳</p> 
<p>㉑</p> 		

ILLUSTRATED SYMBOLS (Refer to the illustration)

Illustrated symbols ① to ⑧ are designed as thumb tabs to indicate the chapter's number and content.

- ① General information
- ② Periodic inspection and adjustment
- ③ Engine
- ④ Cooling system
- ⑤ Carburetion
- ⑥ Chassis
- ⑦ Electrical
- ⑧ Appendices







Illustrated symbols ⑨ to ⑭ are used to identify the specifications appearing in the text.

- ⑨ Filling fluid
- ⑩ Lubricant
- ⑪ Tightening
- ⑫ Wear limit, clearance
- ⑬ Engine speed
- ⑭ Ω , V, A

Illustrated symbols ⑮ to ㉑ in the exploded diagram indicate grade of lubricant and location of lubrication point.

- ⑮ Apply engine oil
- ⑯ Apply gear oil
- ⑰ Apply molybdenum disulfide oil
- ⑱ Apply wheel bearing grease
- ⑲ Apply lightweight lithium-soap base grease
- ⑳ Apply molybdenum disulfide grease
- ㉑ Apply locking agent (LOCTITE®)

INDEX

GENERAL INFORMATION	 GEN INFO 1
PERIODIC INSPECTIONS AND ADJUSTMENTS	 INSP ADJ 2
ENGINE OVERHAUL	 ENG 3
CARBURETION	 CARB 4
CHASSIS	 CHAS 5
ELECTRICAL	 ELEC 6
APPENDICES	 APPX 7

CHAPTER 1

GENERAL INFORMATION

MOTORCYCLE IDENTIFICATION1-1

 VEHICLE IDENTIFICATION NUMBER1-1

 ENGINE SERIAL NUMBER1-1

IMPORTANT INFORMATION1-2

 ALL REPLACEMENT PARTS1-2

 GASKETS, OIL SEALS, AND O-RINGS1-2

 LOCK WASHERS/PLATES AND COTTER PINS1-2

 BEARINGS AND OIL SEALS1-2

SPECIAL TOOLS1-3

 FOR TUNE UP1-3

 FOR ENGINE SERVICE1-4

 FOR CHASSIS SERVICE1-7

 FOR ELECTRICAL COMPONENTS1-7

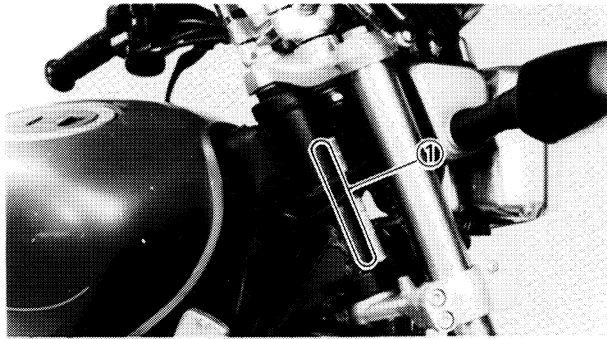

**GENERAL
INFORMATION**

**MOTORCYCLE IDENTIFICATION
VEHICLE IDENTIFICATION NUMBER**

The vehicle identification number ① is stamped into the right side of the steering head pipe.

Starting Serial Number:
YX600S (Except for California)
JYA1UJ00*GA000101
YX600SC (For California)
JYA1UL00*GA000101

NOTE: _____
The vehicle identification number is used to identify your motorcycle and may be used to register your motorcycle with the licensing authority in your state.

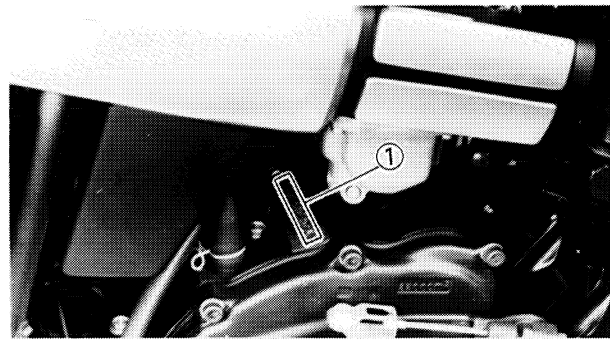

ENGINE SERIAL NUMBER

The engine serial number ① is stamped into the elevated part of the left rear section of the engine.

Starting Serial Number:
YX600S (Except for California)
1UJ-000101
YX600SC (For California)
1UL-000101

NOTE: _____
•The first three digits of these numbers are for model identifications; the remaining digits are the unit production number.
•Designs and specifications are subject to change without notice.

IMPORTANT INFORMATION

ALL REPLACEMENT PARTS

1. Use only genuine Yamaha parts for all replacements. Use oil and/or grease recommended by Yamaha for assembly and adjustment. Other brands may be similar in function and appearance, but inferior in quality.

GASKETS, OIL SEALS, AND O-RINGS

1. All gaskets, seals and O-rings should be replaced when an engine is overhauled. All gasket surfaces, oil seal lips and O-rings must be cleaned.
2. Properly oil all mating parts and bearings during reassembly. Apply grease to the oil seal lips.

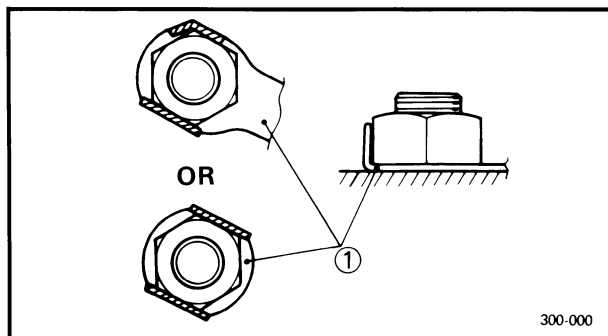

LOCK WASHERS/PLATES AND COTTER PINS

1. All lock washers/Plates ① and cotter pins must be replaced when they are removed. Lock tab(s) should be bent along the bolt or nut flat(s) after the bolt or nut has been properly tightened.

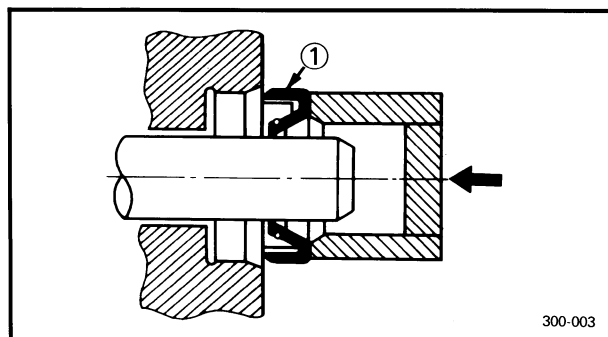

BEARINGS AND OIL SEALS

1. Install the bearing(s) and oil seal(s) with their manufacturer's marks or numbers facing outward. (In other words, the stamped letters must be on the side exposed to view.) When installing oil seal(s), apply a light coating of light-weight lithium base grease to the seal lip(s). Oil the bearings liberally when installing.

① Oil seal

CAUTION:

Do not use compressed air to spin the bearings dry. This causes damage to the bearing surfaces.

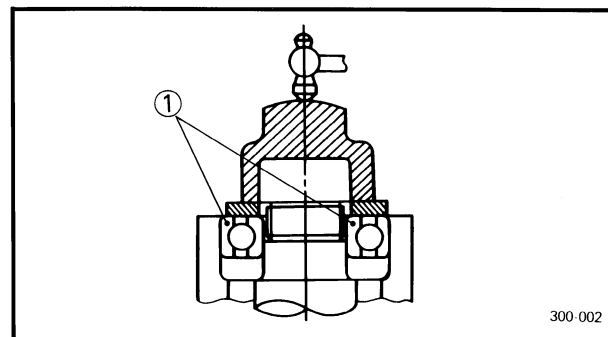

① Bearing



SPECIAL TOOLS

The proper special tools are necessary for complete and accurate tune-up and assembly. Using the correct special tool will help prevent damage caused by the use of improper tools or improvised techniques.

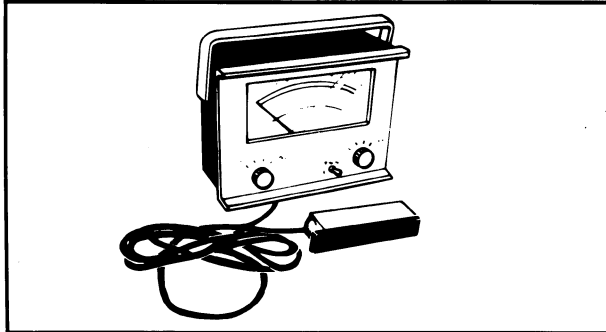

FOR TUNE UP

1. Inductive Tachometer
P/N. YU-08036

This tool is needed for detecting engine rpm.

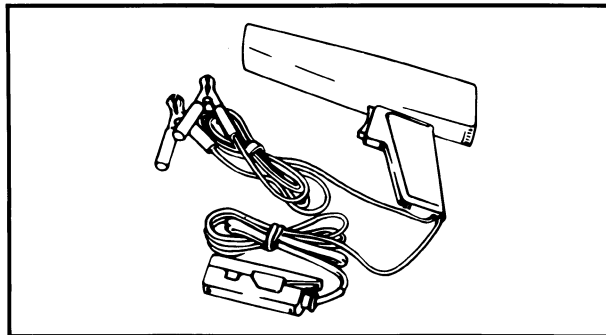

2. Inductive Timing Light
P/N. YU-08037

This tool is necessary for adjusting timing.

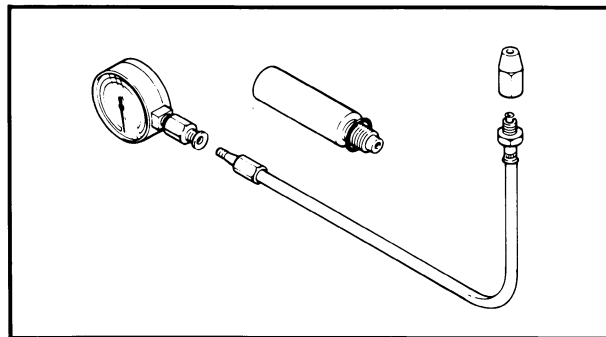

3. Compression Gauge
P/N. YU-33223

This gauge is used to measure the engine compression.

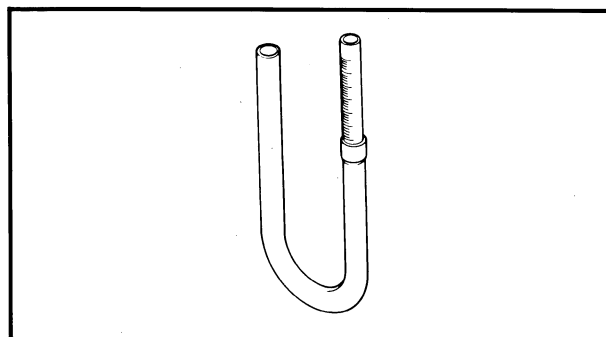

4. Fuel Level Gauge
P/N. YM-01312

This gauge is used to measure the fuel level in the float chamber.

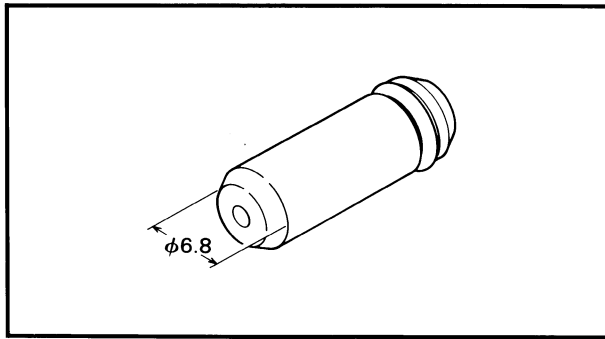

5. Fuel Level Gauge Adapter
P/N. YM-01329

This tool is needed when measuring the carburetor fuel level together with fuel level gauge.

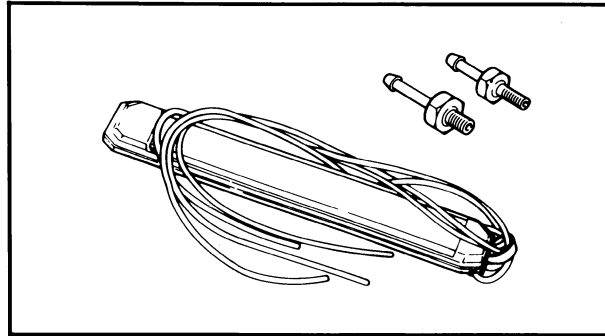

6. Vacuum Gauge
P/N. YU-08030

This gauge is needed for carburetor synchronization.

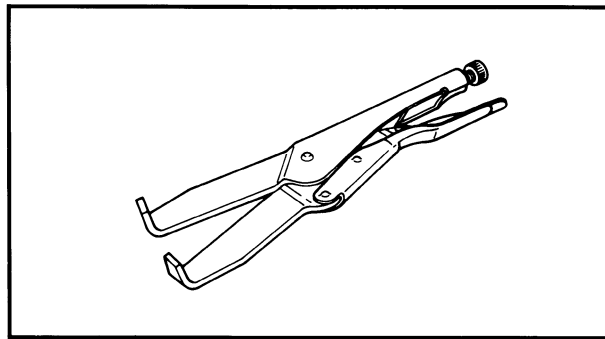

FOR ENGINE SERVICE

1. Universal Clutch Holder
P/N. YM-91042

This tool is used to hold the clutch when removing or installing the clutch boss locknut.

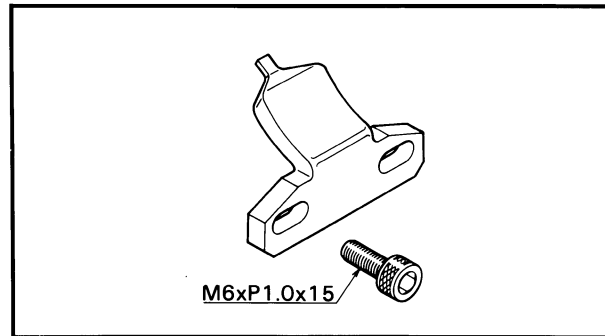

2. Tappet Adjusting Tool
P/N. YM-01245

This tool is necessary to replace valve adjusting pads.

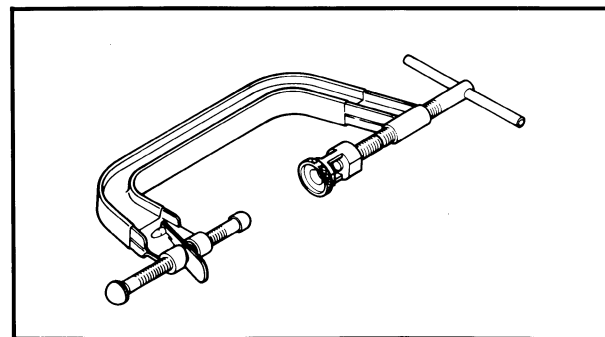

3. Valve Spring Compressor
P/N. YM-04019

This tool is needed to remove and install the valve assemblies.

1

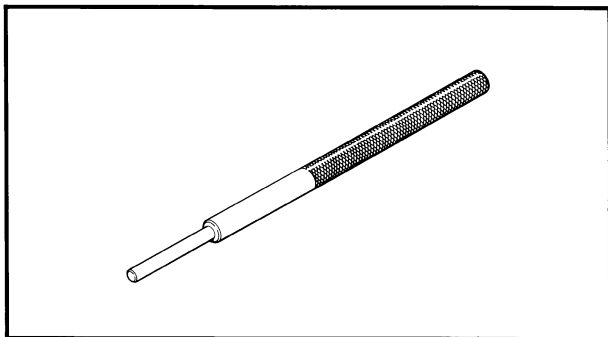

4. Valve Guide Remover
P/N. YM-04064

This tool is used to remove the valve guides.

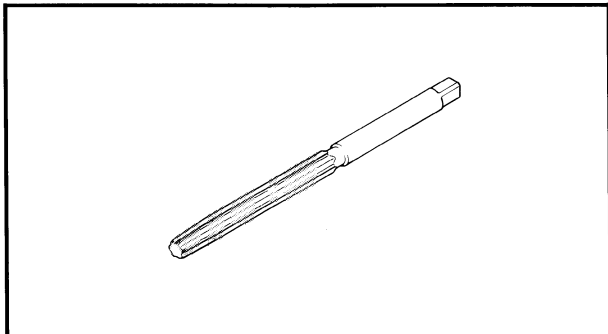

5. Valve Guide Reamer
P/N. YM-04066

This tool is used to rebores the new valve guide.

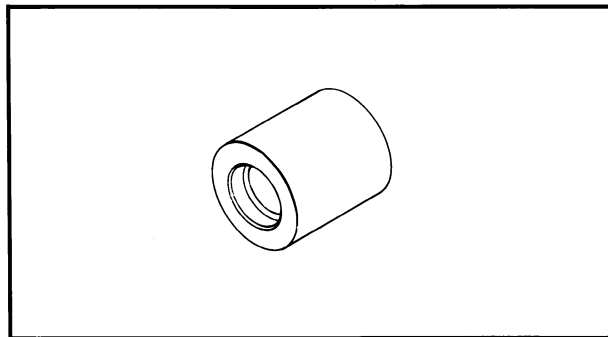

6. Valve Guide Installer
P/N. YM-04065

This tool is needed to install the valve guides properly together with valve guide remover.

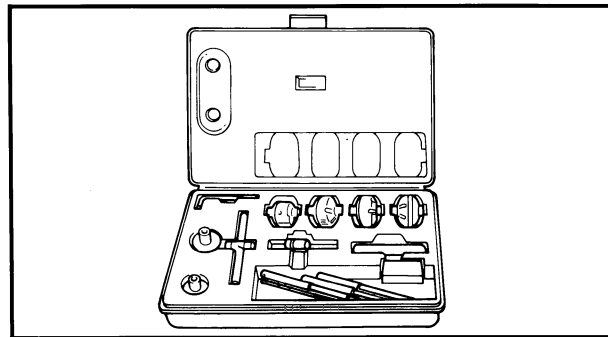

7. Valve Seat Cutter Set
P/N. YM-91043

This tool is needed to resurface the valve seat.

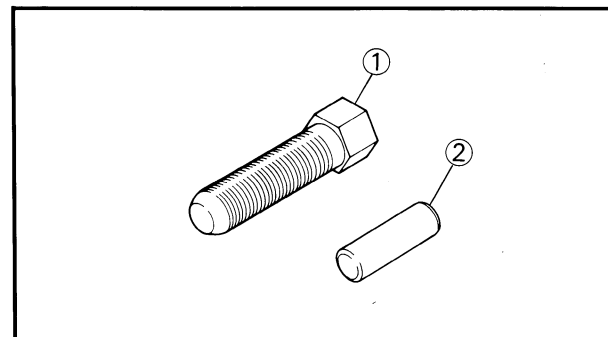

8. Rotor Puller ①
P/N. YM-01080
Pin ②
P/N. YM-04052

This tool is needed to remove the A.C. Generator rotor.

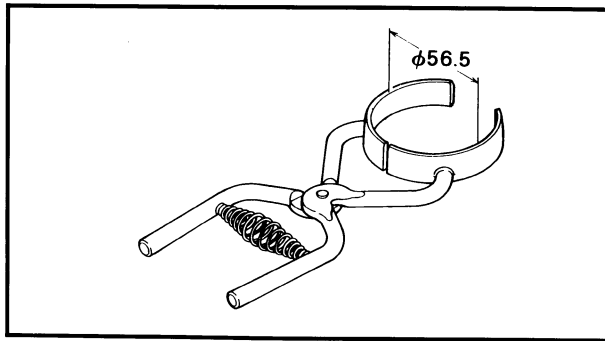

9. Piston Ring Compressor
P/N. YM-04047

This tool is used when installing the piston into the cylinder.

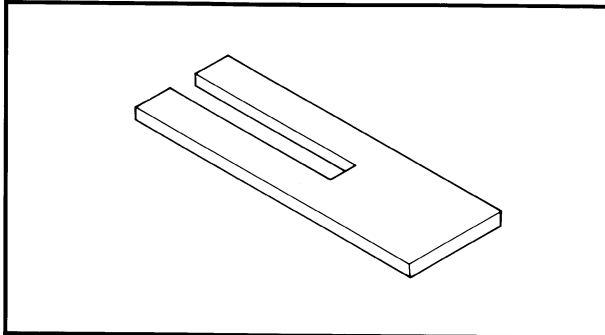

10. Piston Base
P/N. YM-01067

Use 4 of these to hold the pistons during cylinder installation.

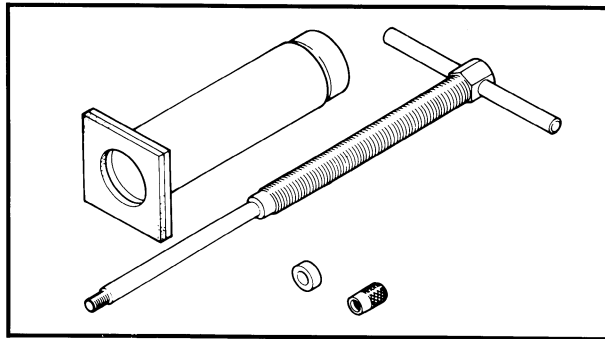

11. Piston Pin Puller
P/N. YU-01304

This tool is used to remove the piston pin.

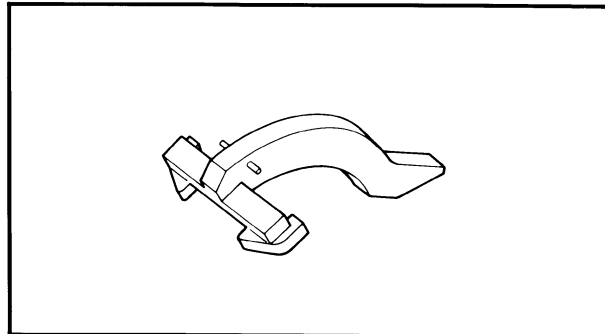

12. Rotor Holding Tool
P/N. YM-04043

This tool is used to hold the A.C. Generator rotor during removal and installation.

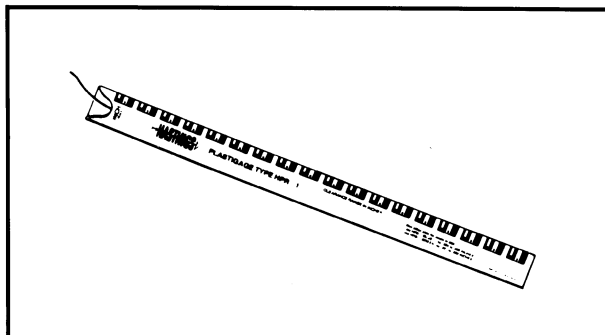

13. Plastigage® Set "Green"
P/N. YU-33210

This gauge is needed to measure the clearance for the connecting rod bearing.

1

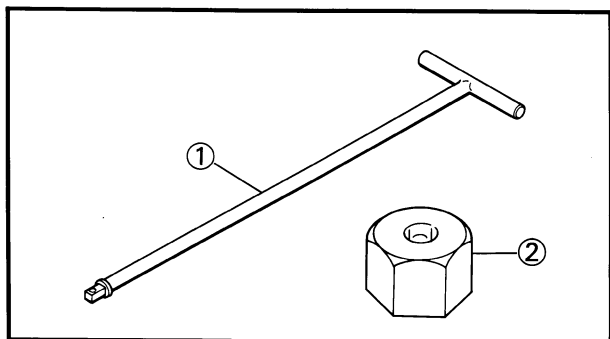

FOR CHASSIS SERVICE

- 1. T-Handle ①
P/N. YM-01326
- Front Fork Cylinder Holder ②
P/N. YM-33298

This tool is used to loosen and tighten the front fork cylinder holding bolt.

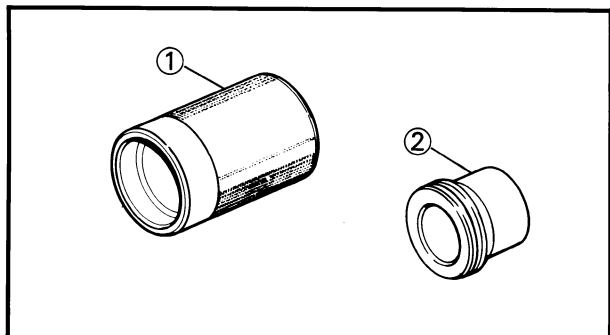

- 2. Front Fork Seal Driver (Weight) ①
P/N. YM-33963
- Adapter ②
P/N. YM-08010

These tools are used when installing the fork seal.

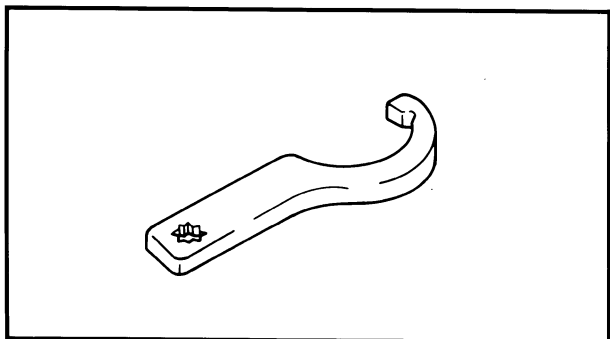

- 3. Ring Nut Wrench
P/N. YU-33975

This tool is used to loosen and tighten the steering ring nut.

FOR ELECTRICAL COMPONENTS

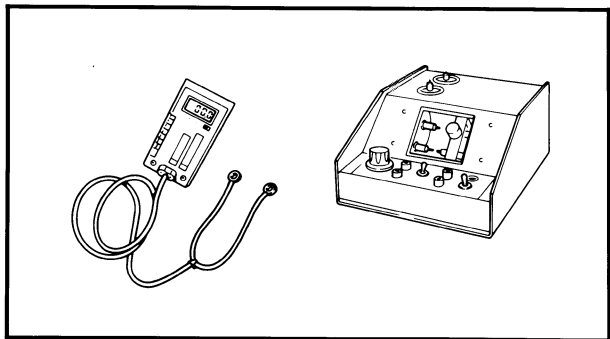

- 1. Electro Tester
P/N. YU-33260

This instrument is necessary for checking the ignition system components.

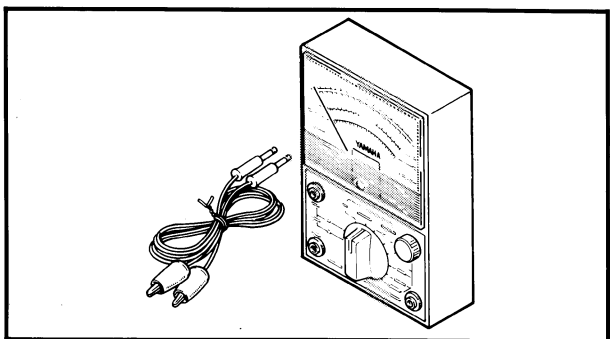

- 2. Pocket Tester
P/N. YU-03112

This instrument is invaluable for checking the electrical system.

CHAPTER 2

PERIODIC INSPECTIONS AND ADJUSTMENTS

INTRODUCTION	2-1
MAINTENANCE INTERVALS CHART	2-1
PERIODIC MAINTENANCE EMISSION CONTROL SYSTEM	2-1
GENERAL MAINTENANCE/LUBRICATION	2-2
ENGINE	2-4
VALVE CLEARANCE ADJUSTMENT	2-4
CAM CHAIN ADJUSTMENT	2-9
CARBURETOR SYNCHRONIZATION	2-10
IDLE SPEED ADJUSTMENT	2-12
ENGINE OIL LEVEL INSPECTION	2-12
ENGINE OIL REPLACEMENT	2-13
CLUTCH LEVER FREE PLAY ADJUSTMENT	2-16
COMPRESSION PRESSURE MEASUREMENT	2-16
FUEL LINE INSPECTION	2-18
CARBURETOR JOINT INSPECTION	2-18
CRANKCASE VENTILATION PIPE INSPECTION	2-19
EXHAUST SYSTEM INSPECTION	2-19
AIR FILTER CLEANING	2-20
CHASSIS	2-20
FUEL COCK CLEANING	2-20
FRONT BRAKE FLUID INSPECTION	2-21
FRONT BRAKE PAD INSPECTION	2-22
FRONT BRAKE LEVER FREE PLAY ADJUSTMENT	2-22
REAR BRAKE PEDAL HEIGHT ADJUSTMENT	2-23
BRAKE PEDAL FREE PLAY ADJUSTMENT	2-23
REAR BRAKE LINING INSPECTION	2-24
REAR BRAKE LIGHT SWITCH ADJUSTMENT	2-24
DRIVE CHAIN SLACK CHECK	2-25
DRIVE CHAIN SLACK ADJUSTMENT	2-25
DRIVE CHAIN LUBRICATION	2-26
CABLE INSPECTION AND LUBRICATION	2-26
LEVER AND PEDAL LUBRICATION	2-27
CENTERSTAND AND SIDESTAND LUBRICATION	2-27
FRONT FORK OIL CHANGE	2-27
REAR SHOCK ABSORBER ADJUSTMENT	2-29
STEERING HEAD INSPECTION	2-29
STEERING HEAD ADJUSTMENT	2-30
FRONT WHEEL BEARING INSPECTION	2-30
REAR WHEEL BEARING INSPECTION	2-31
TUBELESS TIRES AND ALUMINUM WHEELS INSPECTION	2-31
THROTTLE CABLE ADJUSTMENT	2-33



ELECTRICAL	2-33
IGNITION TIMING CHECK	2-33
SPARK PLUG INSPECTION	2-34
BATTERY INSPECTION	2-35
FUSE INSPECTION	2-37
HEADLIGHT BEAM ADJUSTMENT	2-38
HEADLIGHT BULB REPLACEMENT	2-39
TAILLIGHT BULB REPLACEMENT	2-40
CARBURETOR AIR VENT SYSTEM INSPECTION (CALIFORNIA ONLY)	2-40

PERIODIC INSPECTIONS AND ADJUSTMENTS

INTRODUCTION

This chapter includes all information necessary to perform recommended inspections and adjustments. These preventive maintenance procedures, if followed, will ensure more reliable vehicle operation and a longer service life. The need for costly overhaul work will be greatly reduced. This information applies to vehicles already in service as well as new vehicles that are being prepared for sale. All service technicians should be familiar with this entire chapter.

MAINTENANCE INTERVALS CHART

Proper periodic maintenance is important. Especially important are the maintenance services related to emissions controls. These controls not only function to ensure cleaner air but are also vital to proper engine operation and maximum performance. In the following maintenance tables, the services related to emissions control are grouped separately.

PERIODIC MAINTENANCE EMISSION CONTROL SYSTEM

No.	Item	Remarks	Initial	Odometer readings					
			1,000 km or 1 month (600 mi)	**1 7,000 km or 7 months (4,400 mi)	**2 13,000 km or 13 months (8,200 mi)	19,000 km or 19 months (12,000 mi)	**3 25,000 km or 25 months (15,800 mi)	31,000 km or 31 months (19,600 mi)	
1*	Cam chain	Adjust chain tension.	*○	○	○	○	○	○	
2*	Valve clearance	Check and adjust valve clearance when engine is cold.					○		
3*	Spark plug	Check condition. Adjust gap and clean. Replace at 13,000 km (or 13 months) and thereafter every 12,000 km (or 12 months).		○	Replace	○	Replace	○	
4*	Crankcase ventilation system	Check ventilation hose for cracks or damage. Replace if necessary.		○	○	○	○	○	
5*	Fuel line	Check fuel hose and vacuum pipe for cracks or damage. Replace if necessary.		○	○	○	○	○	
6*	Exhaust system	Check for leakage. Retighten if necessary. Replace gasket(s) if necessary.		○	○	○	○	○	
7*	Carburetor synchronization	Adjust synchronization of carburetors.	*○	○	○	○	○	○	
8*	Idle speed	Check and adjust engine idle speed. Adjust cable free play.		○	○	○	○	○	

* It is recommended that these items be serviced by a Yamaha dealer or other qualified mechanic.

NOTE:

For father odometer reading, repeat the above maintenance at the period established; **1: Every 6,000 km (3,800 mi), **2: Every 12,000 km (7,600 mi), and **3: Every 30,000 km (19,000 mi) intervals.

MAINTENANCE INTERVALS CHART



GENERAL MAINTENANCE/LUBRICATION

No.	Item	Remarks	Type	Initial	Odometer readings					
				1,000 km or 1 month (600 mi)	**1 7,000 km or 7 months (4,400 mi)	**2 13,000 km or 13 months (8,200 mi)	19,000 km or 19 months (12,000 mi)	**3 25,000 km or 25 months (15,800 mi)	31,000 km or 31 months (19,600 mi)	
1	Engine oil	Warm-up engine before draining	*1) Yamalube 4-cycle oil or SAE 20W40 type "SE" motor oil *2) SAE 10W30 type "SE" motor oil	○	○	○	○	○	○	
2	Oil filter	Replace.	—	○		○		○		
3*	Air filter	Clean with compressed air. Replace if necessary.	—		○	○	○	○	○	
4*	Brake system	Adjust free play. Replace pads if necessary. (Front) Replace shoes if necessary. (Rear)	—	○	○	○	○	○	○	
5*	Clutch	Adjust free play.	—	○	○	○	○	○	○	
6	Drive chain	Check chain condition. Adjust and lubricate chain thoroughly.	SAE 30W-50W motor oil.	Every 500 km (300 mi)						
7	Control and meter cable	Apply chain lube thoroughly.	Yamaha chain and cable lube or SAE 10W30 motor oil.	○	○	○	○	○	○	
8*	Rear arm pivot bearing	Check bearing assembly for looseness. Moderately repack every 24,000 km (15,200 mi).	Medium weight wheel bearing grease.					Repack		
9	Brake/Clutch lever pivot shaft	Apply chain lube lightly.	Yamaha chain and cable lube or SAE 10W30 motor oil.		○	○	○	○	○	
10	Brake pedal and change pedal shaft	Lubricate. Apply chain lube lightly.	Yamaha chain and cable lube or SAE 10W30 motor oil.		○	○	○	○	○	
11*	Center/Side stand pivots	Check operation and lubricate. Apply chain lube lightly.	Yamaha chain and cable lube or SAE 10W30 motor oil.		○	○	○	○	○	

2

MAINTENANCE INTERVALS CHART

No.	Item	Remarks	Type	Initial	Odometer readings					
				1,000 km or 1 month (600 mi)	**1 7,000 km or 7 months (4,400 mi)	**2 13,000 km or 13 months (8,200 mi)	19,000 km or 19 months (12,000 mi)	**3 25,000 km or 25 months (15,800 mi)	31,000 km or 31 months (19,600 mi)	
12*	Front fork oil	Check operation and leakage.	Yamaha Fork Oil 10WT or equivalent		○	○	○	○	○	
13*	Steering bearing	Check bearings assembly for looseness. Moderately repack every 24,000 km (15,000 mi).	Medium weight wheel bearing grease.		○	○	○	Repack	○	
14*	Wheel bearings	Check bearings for smooth rotation.	Medium weight wheel bearing grease		○	○	○	○	○	
15	Battery	Check specific gravity and breather pipe for proper operation.	—		○	○	○	○	○	
16*	A.C. Generator	Replace generator brushes.	—			○		○		
17*	Sidestand switch	Check and clean or replace if necessary.	—	○	○	○	○	○	○	

*1) If ambient temperature does not go below 5°C (41°F).

*2) If ambient temperature does not go below 15°C (59°F).

* It is recommended that these items be serviced by a Yamaha dealer or other qualified mechanic.

NOTE: _____

For father odometer reading, repeat the above maintenance at the period established, **1: Every 6,000 km (3,800 mi), **2: Every 12,000 km (7,600 mi) and **3: Every 24,000 km (15,200 mi) intervals.

ENGINE

VALVE CLEARANCE ADJUSTMENT

NOTE:

- Valve clearance must be measured and adjusted when the engine is cool to the touch.
- Measure and adjust valve clearance when piston is at TDC on compression stroke.

1. Remove:

- Seat

2. Turn the fuel cock to "ON" position.

2

3. Remove:

- Cover ①

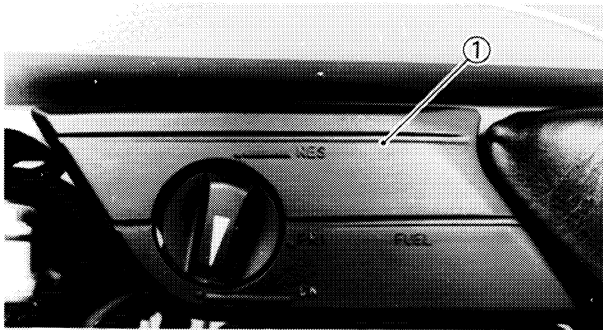

4. Disconnect:

- Fuel pipe ①
- Vacuum pipe ②
- Fuel tank breather pipe ③

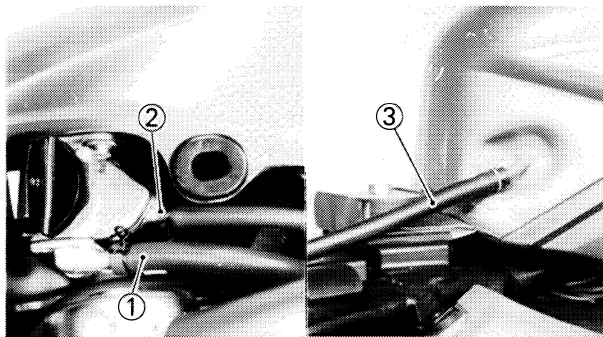

5. Remove:

- Fuel tank



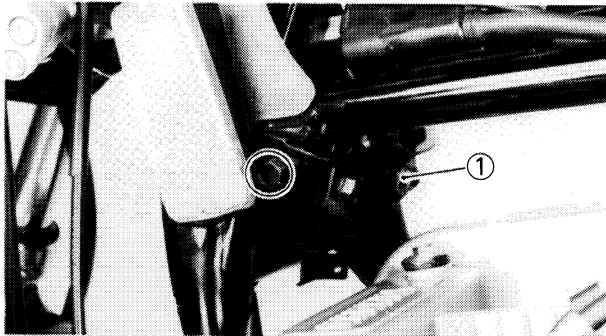

6. Remove:
- Spark plugs
 - Horn ①

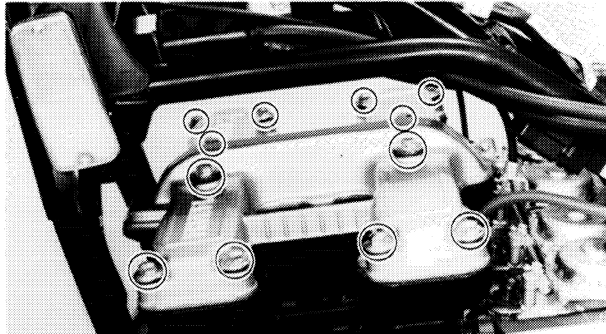

7. Remove:
- Cylinder head cover

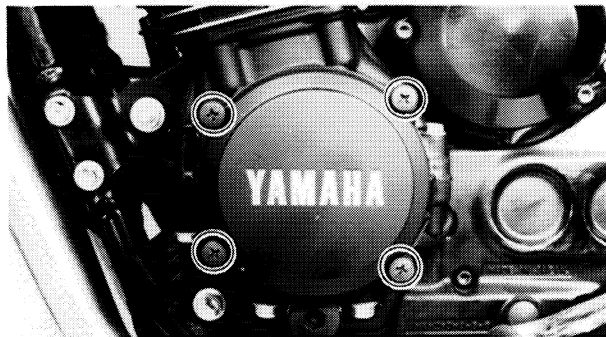

8. Remove:
- Crankcase cover

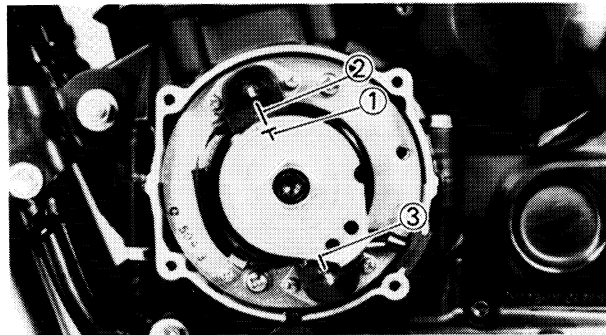

9. Measure:
- Valve clearance

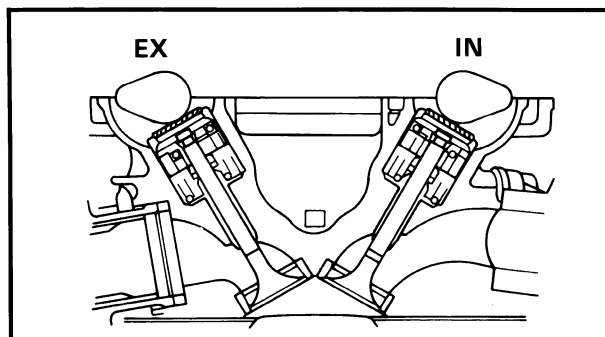

Valve clearance measurement steps:

- Turn the crankshaft counterclockwise.
- Align the "T" mark ① on the timing plate with the pickup coil mark (② or ③) when the piston is at Top Dead Center (T.D.C.) on compression stroke.

NOTE:

- Compression T.D.C. can be found when the cam lobes are apart from each other, as shown.
- Measure the valve clearance by aligning the "T" mark with the upper pickup coil mark ② for the #1 and #4 cylinders and with the lower pickup coil mark ③ for the #2 and #3 cylinders.

VALVE CLEARANCE ADJUSTMENT

INSP
ADJ

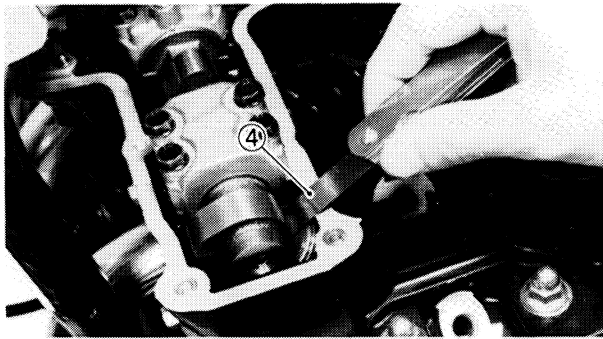

- Measure the valve clearance using feeler gauge ④.
- Out of specification → Adjust valve clearance.



Intake Valve (Cold):
0.11 ~ 0.15 mm (0.004 ~ 0.006 in)

Exhaust Valve (Cold):
0.16 ~ 0.20 mm (0.006 ~ 0.008 in)

NOTE:

- Record the measured amount if the clearance is incorrect.
- Measure valve clearance in sequence.

Measuring Sequence:

1 → # 2 → # 4 → # 3

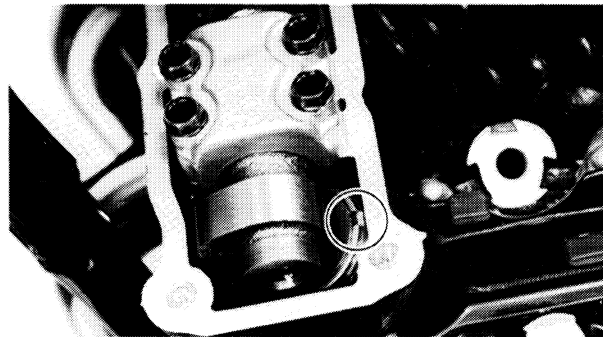
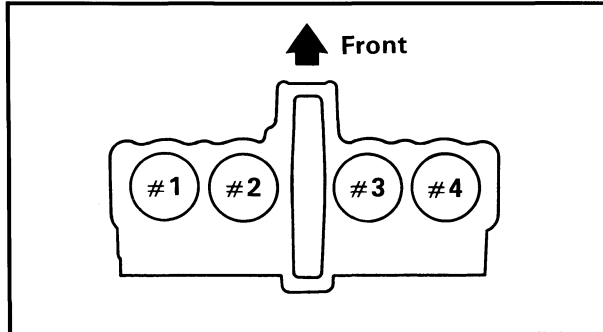

10. Adjust:
- Valve clearance

Valve clearance adjustment steps:

- Position the valve lifter slots (intake and exhaust) opposite each other.

- Turn the camshaft until the lobe fully depresses the valve lifter and opens the valve.
- Attach the Tappet Adjusting Tool ① (YM-01245) onto the cylinder head.

NOTE:

Make sure that the tool contacts the lifter ③ only, and not the pad ②.

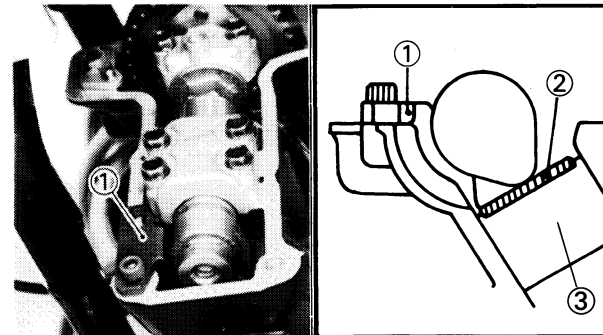

- Carefully rotate the camshaft so that the pads can be removed. To avoid cam touching the adjusting tool, turn cams as shown.

Intake: Carefully rotate CLOCKWISE.

Exhaust:

Carefully rotate COUNTER-CLOCKWISE.

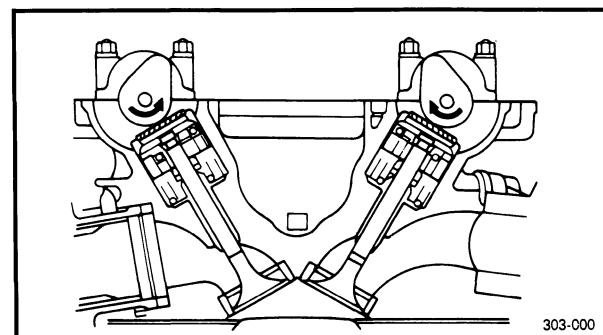

303-000

2

VALVE CLEARANCE ADJUSTMENT

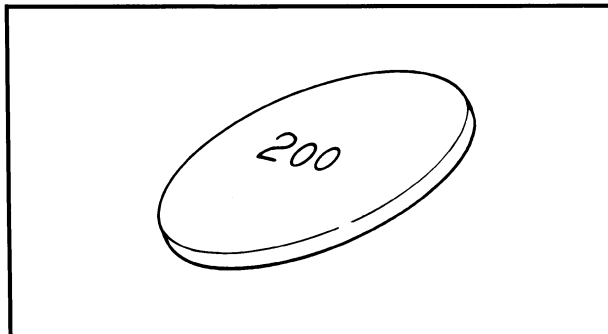
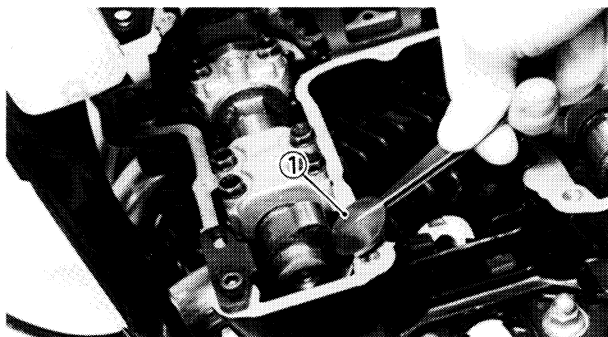

- Remove the pads ① from the lifters. Use a small screwdriver and a pair of tweezers for removal.

Note pad numbers.

- Select the proper valve adjusting pad from the chart below:

Pad range		Pad availability: 25 increments
No. 200 ~ No. 320	200 mm (0.079 in) 320 mm (0.130 in)	Pads stepped in 0.05 mm (0.002 in) increments

NOTE: _____

Thickness of each pad is marked on the pad face that contacts the valve lifter (not the cam).

- Round off the hundredths digit of the original pad number to the nearest 0.05 mm increment.

Hundredths digit	Rounded valve
0 or 2	0
5	(NOT ROUNDED OFF)
8	10

EXAMPLE:

Original pad number = 258 (2.58 mm)

Rounded off digit = 260

NOTE: _____

Pads can only be selected in 0.05 mm (0.002 in) increments.

- Locate the "Installed Pad Number" on the chart, and then find the measured valve clearance. The point where these coordinates intersect is the new pad number.

NOTE: _____

Use the new pad number as a guide only as the number must be verified.

VALVE CLEARANCE ADJUSTMENT



INTAKE

[B] MEASURED CLEARANCE	[A] INSTALLED PAD NUMBER																															
	200	205	210	215	220	225	230	235	240	245	250	255	260	265	270	275	280	285	290	295	300	305	310	315	320							
0.00 ~ 0.05			200	205	210	215	220	225	230	235	240	245	250	255	260	265	270	275	280	285	290	295	300	305	310	315	320					
0.06 ~ 0.10		200	205	210	215	220	225	230	235	240	245	250	255	260	265	270	275	280	285	290	295	300	305	310	315	320						
0.11 ~ 0.15																																
0.16 ~ 0.20	205	210	215	220	225	230	235	240	245	250	255	260	265	270	275	280	285	290	295	300	305	310	315	320								
0.21 ~ 0.25	210	215	220	225	230	235	240	245	250	255	260	265	270	275	280	285	290	295	300	305	310	315	320									
0.26 ~ 0.30	215	220	225	230	235	240	245	250	255	260	265	270	275	280	285	290	295	300	305	310	315	320										
0.31 ~ 0.35	220	225	230	235	240	245	250	255	260	265	270	275	280	285	290	295	300	305	310	315	320											
0.36 ~ 0.40	225	230	235	240	245	250	255	260	265	270	275	280	285	290	295	300	305	310	315	320												
0.41 ~ 0.45	230	235	240	245	250	255	260	265	270	275	280	285	290	295	300	305	310	315	320													
0.46 ~ 0.50	235	240	245	250	255	260	265	270	275	280	285	290	295	300	305	310	315	320														
0.51 ~ 0.55	240	245	250	255	260	265	270	275	280	285	290	295	300	305	310	315	320															
0.56 ~ 0.60	245	250	255	260	265	270	275	280	285	290	295	300	305	310	315	320																
0.61 ~ 0.65	250	255	260	265	270	275	280	285	290	295	300	305	310	315	320																	
0.66 ~ 0.70	255	260	265	270	275	280	285	290	295	300	305	310	315	320																		
0.71 ~ 0.75	260	265	270	275	280	285	290	295	300	305	310	315	320																			
0.76 ~ 0.80	265	270	275	280	285	290	295	300	305	310	315	320																				
0.81 ~ 0.85	270	275	280	285	290	295	300	305	310	315	320																					
0.86 ~ 0.90	275	280	285	290	295	300	305	310	315	320																						
0.91 ~ 0.95	280	285	290	295	300	305	310	315	320																							
0.96 ~ 1.00	285	290	295	300	305	310	315	320																								
1.01 ~ 1.05	290	295	300	305	310	315	320																									
1.06 ~ 1.10	295	300	305	310	315	320																										
1.11 ~ 1.15	300	305	310	315	320																											
1.16 ~ 1.20	305	310	315	320																												
1.21 ~ 1.25	310	315	320																													
1.26 ~ 1.30	315	320																														
1.31 ~ 1.35	320																															

VALVE CLEARANCE (cold):
 0.11 ~ 0.15 mm (0.004 ~ 0.006 in)
 Example: Installed is 250
 Measured clearance is 0.32 mm (0.013 in)
 Replace 250 pad with 270 pad
 Pad number: (example)
 Pad No. 250 = 2.50 mm (0.098 in)
 Pad No. 255 = 2.55 mm (0.100 in)
 Always install pad with number down.



EXHAUST

[B] MEASURED CLEARANCE	[A] INSTALLED PAD NUMBER																															
	200	205	210	215	220	225	230	235	240	245	250	255	260	265	270	275	280	285	290	295	300	305	310	315	320							
0.00 ~ 0.05				200	205	210	215	220	225	230	235	240	245	250	255	260	265	270	275	280	285	290	295	300	305	310	315	320				
0.06 ~ 0.10			200	205	210	215	220	225	230	235	240	245	250	255	260	265	270	275	280	285	290	295	300	305	310	315	320					
0.11 ~ 0.15		200	205	210	215	220	225	230	235	240	245	250	255	260	265	270	275	280	285	290	295	300	305	310	315	320						
0.16 ~ 0.20																																
0.21 ~ 0.25	205	210	215	220	225	230	235	240	245	250	255	260	265	270	275	280	285	290	295	300	305	310	315	320								
0.26 ~ 0.30	210	215	220	225	230	235	240	245	250	255	260	265	270	275	280	285	290	295	300	305	310	315	320									
0.31 ~ 0.35	215	220	225	230	235	240	245	250	255	260	265	270	275	280	285	290	295	300	305	310	315	320										
0.36 ~ 0.40	220	225	230	235	240	245	250	255	260	265	270	275	280	285	290	295	300	305	310	315	320											
0.41 ~ 0.45	225	230	235	240	245	250	255	260	265	270	275	280	285	290	295	300	305	310	315	320												
0.46 ~ 0.50	230	235	240	245	250	255	260	265	270	275	280	285	290	295	300	305	310	315	320													
0.51 ~ 0.55	235	240	245	250	255	260	265	270	275	280	285	290	295	300	305	310	315	320														
0.56 ~ 0.60	240	245	250	255	260	265	270	275	280	285	290	295	300	305	310	315	320															
0.61 ~ 0.65	245	250	255	260	265	270	275	280	285	290	295	300	305	310	315	320																
0.66 ~ 0.70	250	255	260	265	270	275	280	285	290	295	300	305	310	315	320																	
0.71 ~ 0.75	255	260	265	270	275	280	285	290	295	300	305	310	315	320																		
0.76 ~ 0.80	260	265	270	275	280	285	290	295	300	305	310	315	320																			
0.81 ~ 0.85	265	270	275	280	285	290	295	300	305	310	315	320																				
0.86 ~ 0.90	270	275	280	285	290	295	300	305	310	315	320																					
0.91 ~ 0.95	275	280	285	290	295	300	305	310	315	320																						
0.96 ~ 1.00	280	285	290	295	300	305	310	315	320																							
1.01 ~ 1.05	285	290	295	300	305	310	315	320																								
1.06 ~ 1.10	290	295	300	305	310	315	320																									
1.11 ~ 1.15	295	300	305	310	315	320																										
1.16 ~ 1.20	300	305	310	315	320																											
1.21 ~ 1.25	305	310	315	320																												
1.26 ~ 1.30	310	315	320																													
1.31 ~ 1.35	315	320																														
1.36 ~ 1.40	320																															

VALVE CLEARANCE (cold):
 0.16 ~ 0.20 mm (0.006 ~ 0.008 in)
 Example: Installed is 250
 Measured clearance is 0.32 mm (0.013 in)
 Replace 250 pad with 265 pad
 Pad number: (example)
 Pad No. 250 = 2.50 mm (0.098 in)
 Pad No. 255 = 2.55 mm (0.100 in)
 Always install pad with number down.

Pad number verification steps:

- Install the new pad with the number down.
- Remove the adjusting tool.
- Recheck the valve clearance.
- If the clearance is incorrect, repeat all of the clearance adjustment steps until the proper clearance is obtained.

11. Install:

Reverse removal steps.

- Crankcase cover (Left)
- Cylinder head cover
- Horn
- Spark plugs
- Fuel tank



Screw (Crankcase Cover):

10 Nm (1.0 m•kg, 7.2 ft•lb)

Bolt (Cylinder Head Cover):

10 Nm (1.0 m•kg, 7.2 ft•lb)

Spark Plug:

18 Nm (1.8 m•kg, 13 ft•lb)

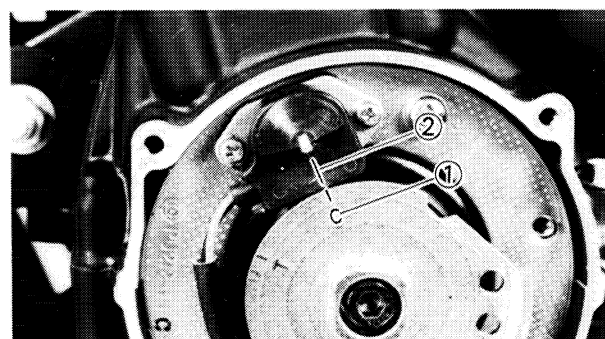
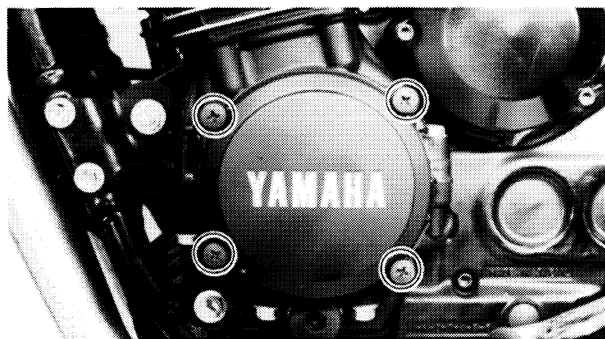

CAM CHAIN ADJUSTMENT

1. Remove:

- Crankcase cover (Left)

2. Turn crankshaft counterclockwise.

3. Align the timing plate "C" mark ① with the upper pickup coil mark ②.

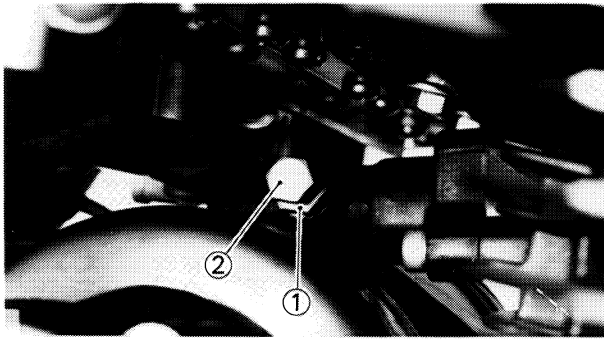

4. Loosen:
- Locknut (Chain tensioner) ①
 - Stopper bolt (Chain tensioner) ②

5. Tighten:
- Locknut (Chain tensioner)
 - Stopper bolt (Chain tensioner)

	Locknut: 6 Nm (0.6 m•kg, 4.3 ft•lb)
	Stopper Bolt: 9 Nm (0.9 m•kg, 6.5 ft•lb)

2

6. Install:
- Crankcase cover (Left)

	Screw (Crankcase Cover): 10 Nm (1.0 m•kg, 7.2 ft•lb)
--	--

CARBURETOR SYNCHRONIZATION

Carburetors must be adjusted to open and close simultaneously.

NOTE: _____

Valve clearance must be set properly before synchronizing the carburetors.

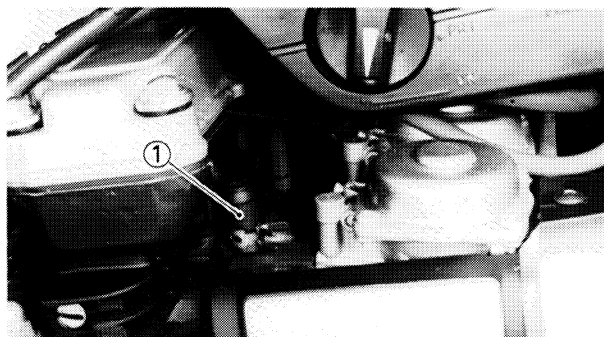

1. Remove:
- Vacuum plugs ①

2. Remove:
 - Seat
 - Side covers (Fuel tank)
 - Bolt (Fuel tank)
3. Install:
 - Vacuum Gauge (YU-08030)
4. Start the engine and let it warm up.
5. Adjust:
 - Idle speed
 Turn the throttle stop screw ①.

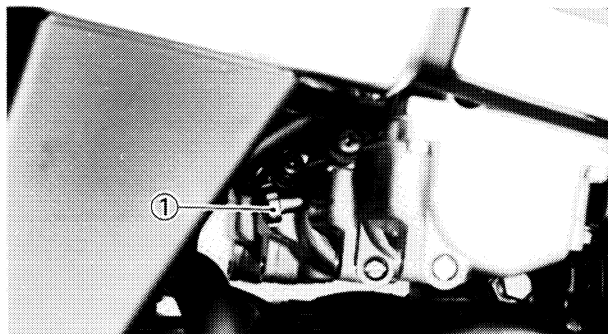

Turn in	Engine speed is increased.
Turn out	Engine speed is decreased.

	Idle Speed: 1,250 ~ 1,350 r/min
---	---------------------------------

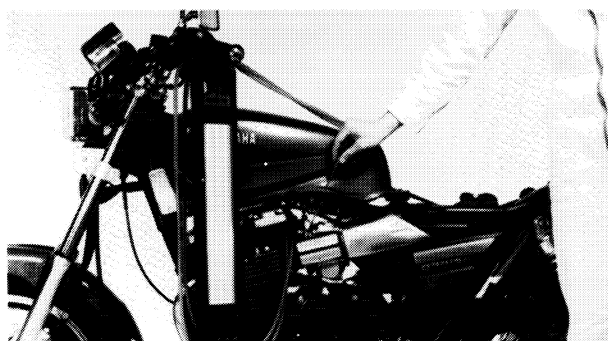
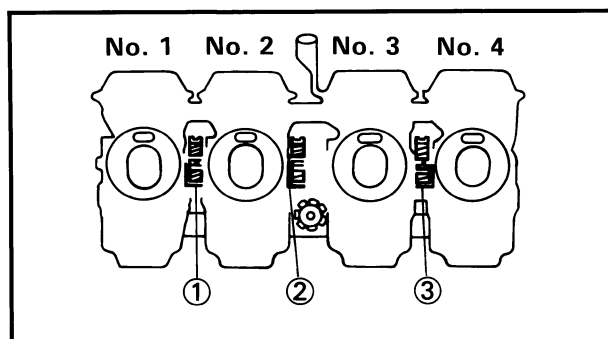

6. Adjust:
 - Carburetors

Carburetor adjustment steps:

- Lift up the rear of fuel tank
- Synchronize carburetor No. 1 to carburetor No. 2 by turning synchronizing screw ① until both gauges read the same.
- Rev the engine for a fraction of a second, two or three times, and check the synchronization again.

Vacuum Pressure at Idle Speed:

22.7 ~ 24.0 kPa

(170 ~ 180 mm Hg, 6.69 ~ 7.09 in Hg)

Vacuum Synchronous Difference:

1.33 kPa (10 mm Hg, 0.4 in Hg)

- Repeat the above steps to synchronize carburetor No. 4 to carburetor No. 3 by turning synchronizing screw ③ until both gauges read the same.
- Repeat the same steps to synchronize No. 2 carburetor to No. 3 carburetor by turning synchronizing screw ② until both gauges read the same.

7. Adjust:
 - Idle speed

8. Install:
 - Bolt (Fuel tank)
 - Side covers (Fuel tank)
 - Seat
 - Vacuum plugs

IDLE SPEED ADJUSTMENT

1. Inspect:
 - Idle speed
 Out of specification → Adjust.

	1,250 ~ 1,350 r/min
---	----------------------------

2

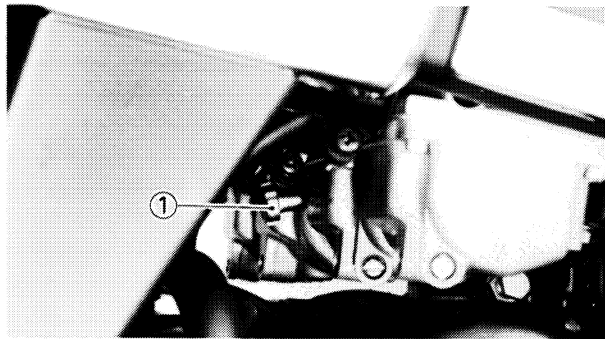

2. Adjust:
 - Idle speed
 Turn the throttle stop screw ①.

Turn in	Engine speed is increased.
Turn out	Engine speed is decreased.

ENGINE OIL LEVEL INSPECTION

1. Place the motorcycle on its centerstand and warm up the engine for several minutes.

NOTE: _____
 Position motorcycle straight up when checking oil level, a slight tilt to the side can produce false readings.

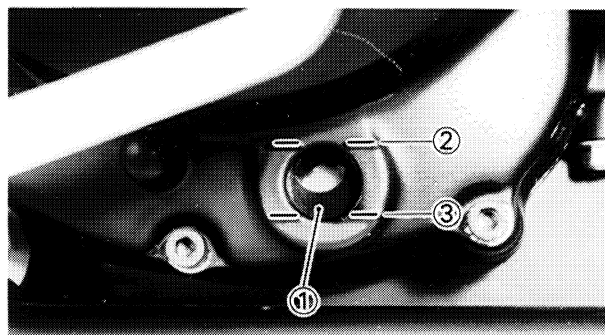

2. Stop the engine and visually check the oil level through the level window ①.

3. Inspect:
 - Oil level
 Oil level should be between maximum ② and minimum ③ marks.
 Oil level low → Add oil to proper level.

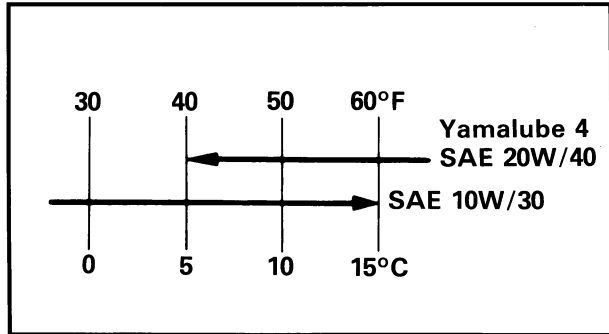

NOTE: _____
 Wait a few minutes until level settles before inspecting.



Recommended Oil:
 At 5°C (40°F) or Higher:
 Yamalube 4-cycle Oil or
 SAE 20W40 Type SE Motor Oil
 At 15°C (60°F) or Lower:
 SAE 10W30 Type SE Motor Oil

ENGINE OIL REPLACEMENT

Without Filter Change

1. Warm up the engine for several minutes, then place a receptacle under the engine.
2. Remove:
 - Oil filler cap
3. Remove:
 - Drain plug ①
 Drain the engine oil.
4. Install:
 - Drain plug ①

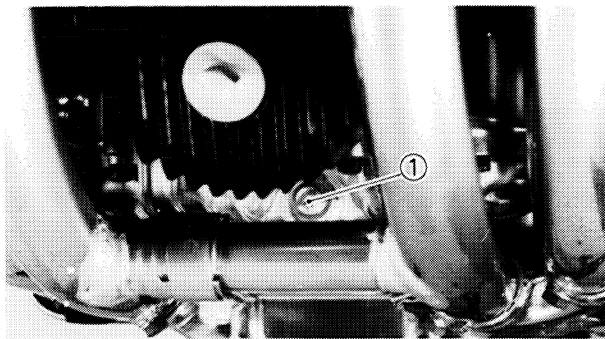

43 Nm (4.3 m•kg, 31 ft•lb)

5. Fill:
 - Crankcase



2.2 L (1.9 Imp qt, 2.3 US qt)

CAUTION: _____

Do not allow foreign material to enter the crankcase.



Recommended Oil:
At 5°C (40°F) or Higher:
 Yamalube 4-cycle Oil or
 SAE 20W40 Type SE Motor Oil
At 15°C (60°F) or Lower:
 SAE 10W30 Type SE Motor Oil

6. Install:
- Oil filler cap

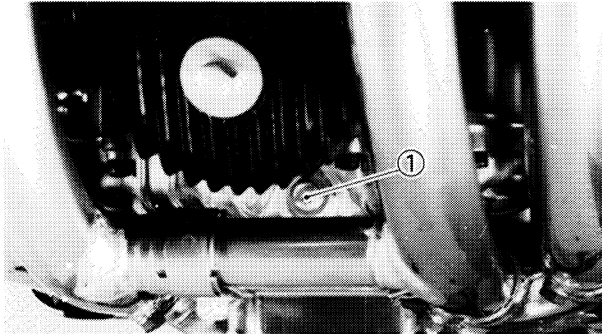

With Filter Change

1. Warm up the engine for several minutes, then place a receptacle under the engine.
2. Remove:
 - Oil filler cap
 - Drain plug ①
 Drain the engine oil.

2

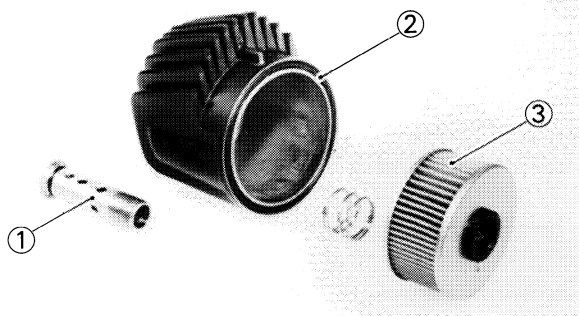

3. Remove:
 - Oil filter bolt ①
 - Filter cover ②
 - Oil filter ③

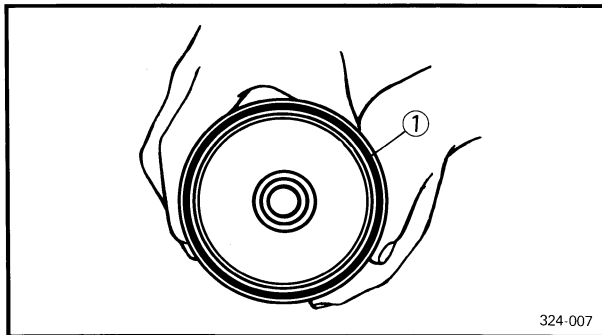

4. Install:
 - Drain plug
 - Oil filter (New)
 - Plain washer
 - Spring
 - Filter cover
 - Oil filter bolt

NOTE: _____
 Be sure the O-ring ① is positioned properly.



Drain Plug:
 43 Nm (4.3 m•kg, 31 ft•lb)
Oil Filter Bolt:
 15 Nm (1.5 m•kg, 11 ft•lb)

5. Fill:
- Crankcase

	2.5 L (2.2 Imp qt, 2.6 US qt)
---	-------------------------------

CAUTION: _____

Do not allow foreign material to enter the crankcase.

	<p>Recommended Oil: At 5°C (40°F) or Higher: Yamalube 4-cycle Oil or SAE 20W40 Type SE Motor Oil At 15°C (60°F) or Lower: SAE 10W30 Type SE Motor Oil</p>
---	---

6. Install:
- Oil filler cap
7. Warm up engine and check for oil leaks.
 Stop engine instantly if leaking occurs.
 Leaks→Check cause.



CAUTION: _____

After replacing the engine oil, be sure to check the oil flow in the following procedures:

- Slightly loosen the oil gallery bolt ① in the cylinder head.
- Start the engine and keep it idling until oil begins to seep from the oil gallery bolt. If no oil comes out after one minute, turn the engine off so it will not seize.
- Restart the engine after solving the problem(s), and recheck the oil pressure.
- After checking, tighten the oil gallery bolt to specification.

	<p>Oil Gallery Bolt: 7 Nm (0.7 m•kg, 5.1 ft•lb)</p>
---	---

CLUTCH LEVER FREE PLAY ADJUSTMENT/ COMPRESSION PRESSURE MEASUREMENT

INSP
ADJ

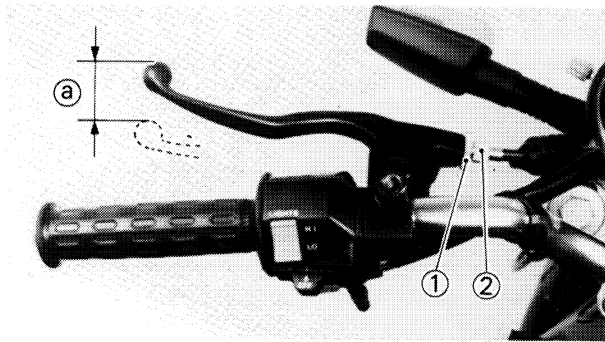

CLUTCH LEVER FREE PLAY ADJUSTMENT

1. Loosen:
 - Locknut ①

2. Adjust:
 - Clutch lever free play ①
 - Turn the adjuster ② in or out.

Turn in	Free play is increased.
Turn out	Free play is decreased.

	Free Play:
	10 ~ 15 mm (0.4 ~ 0.6 in)

2

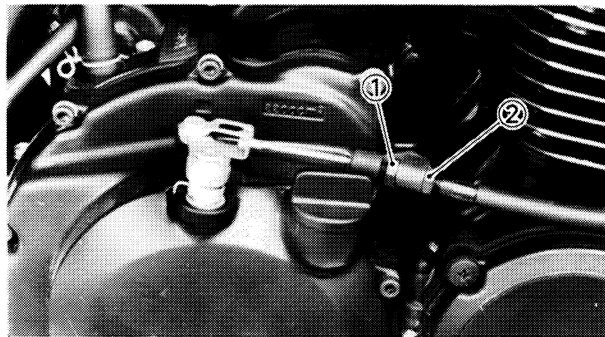

3. If free play can not be adjusted, adjust free play by the adjuster ① at right side of the crankcase.

4. Loosen:
 - Locknut ②

5. Adjust:
 - Clutch lever free play
 - Turn the adjuster in or out.

Turn in	Free play is increased.
Turn out	Free play is decreased.

6. Tighten:
 - Locknut

COMPRESSION PRESSURE MEASUREMENT

NOTE: _____

Insufficient compression pressure will result in performance loss.

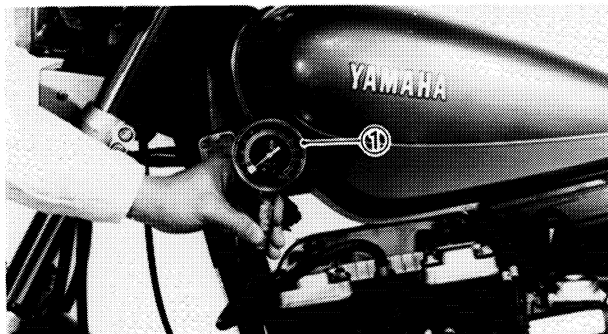

1. Measure:
 - Valve clearance
Out of specification → Adjust.
Refer to "VALVE CLEARANCE ADJUSTMENT" section.
2. Warm up the engine.
3. Remove:
 - Spark plugs
4. Measure:
 - Compression pressure

Compression pressure measurement steps:

- Install the Compression Gauge (YU-33223) ① using an adapter.
- Crank over the engine with the electric starter (be sure the battery is fully charged) with the throttle wide open until the compression reading on the gauge stabilizes.
- Check readings with specified levels (See chart).

Compression Pressure

(At sea level):

Standard:

1,079 kPa (11 kg/cm², 156 psi)

Minimum:

980 kPa (10 kg/cm², 142 psi)

Maximum:

1,128 kPa (11.5 kg/cm², 164 psi)

WARNING:

When cranking the engine, ground spark plug lead to prevent sparking.

- Repeat the previous steps for the other cylinders.
- If pressure falls below the minimum level:
 1. Squirt a few drops of oil into the affected cylinder.
 2. Measure the compression again.



Compression Pressure (with oil introduced into cylinder)	
Reading	Diagnosis
Higher than without oil	Worn or damaged pistons
Same as without oil	Defective ring(s), valves, cylinder head gasket or piston is possible.
Above maximum level	Inspect cylinder head, valve surfaces, or piston crown for carbon deposits.

NOTE: _____

The difference between the highest and lowest cylinder compression readings must not vary more than the specified value.

2

**Difference Between Each Cylinder:
Less than 98 kPa (1 kg/cm², 14 psi)**

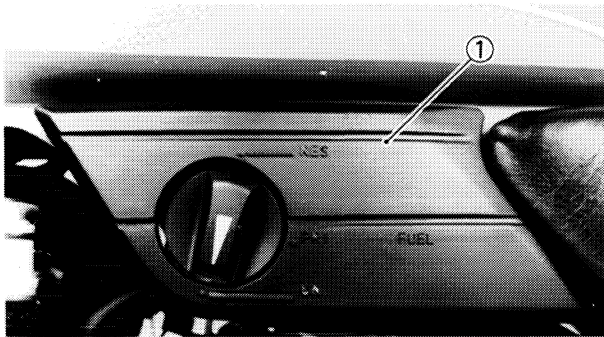

FUEL LINE INSPECTION

1. Remove:
 - Cover ①

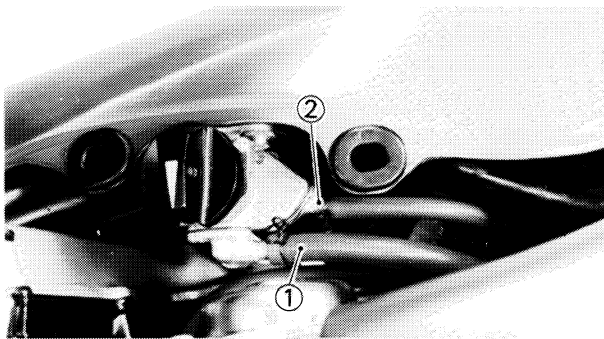

2. Inspect:
 - Fuel pipe ①
 - Vacuum pipe ②
 Cracks/Damage → Replace.

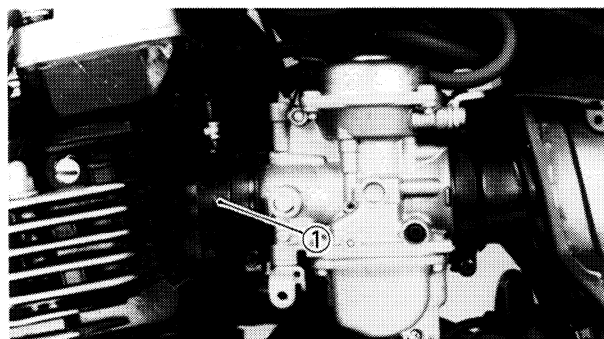

CARBURETOR JOINT INSPECTION

1. Inspect:
 - Carburetor joint ①
 Cracks/Damage → Replace.

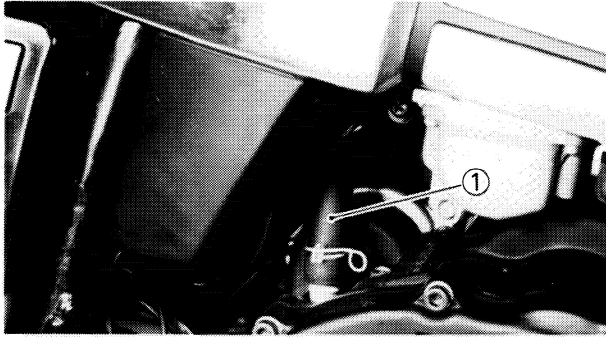

CRANKCASE VENTILATION PIPE INSPECTION

1. Inspect:
 - Crankcase ventilation pipe ①
 - Cracks/Damage→Replace.

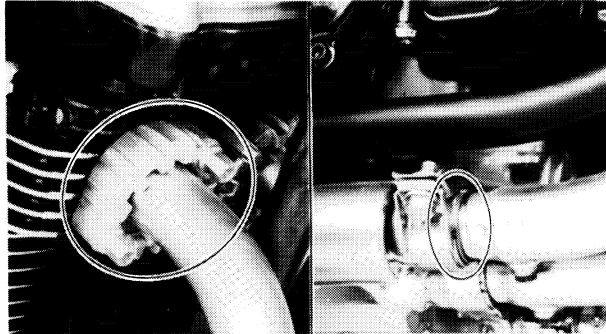

EXHAUST SYSTEM INSPECTION

1. Inspect:
 - Exhaust pipe
 - Muffler
 - Cracks/Damage→Replace.
 - Gaskets
 - Exhaust gas leaks→Replace.

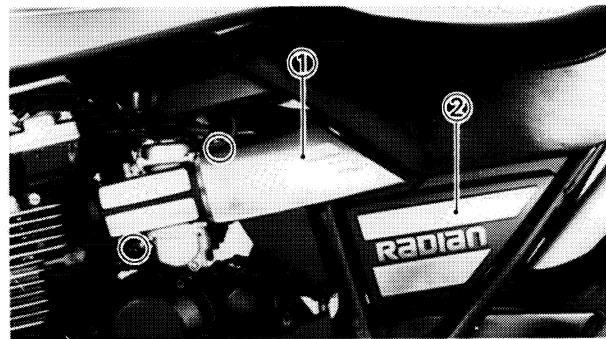

AIR FILTER CLEANING

1. Remove:
 - Cover (Carburetor) ①
 - Side cover (Left) ②

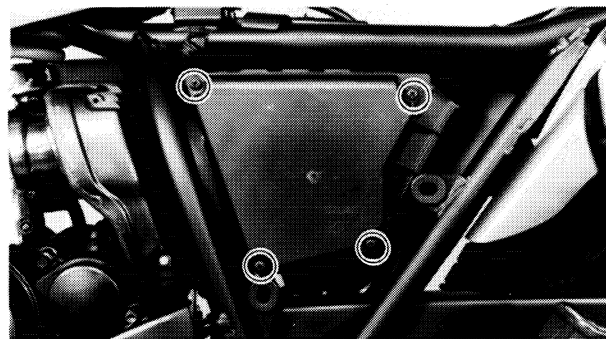

2. Remove:
 - Air filter case cover (Left)

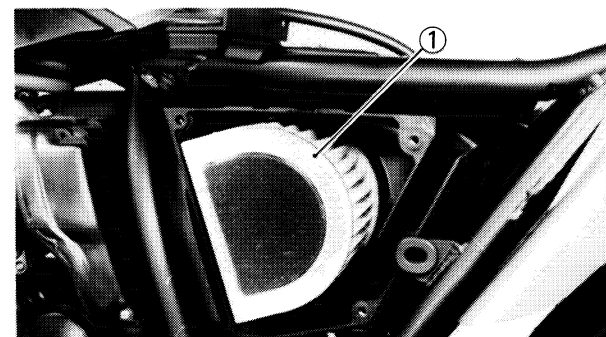

3. Remove:
 - Air filter element ①

CAUTION:

The engine should never be run without the air filter element; excessive piston and cylinder wear may result.

FUEL COCK CLEANING

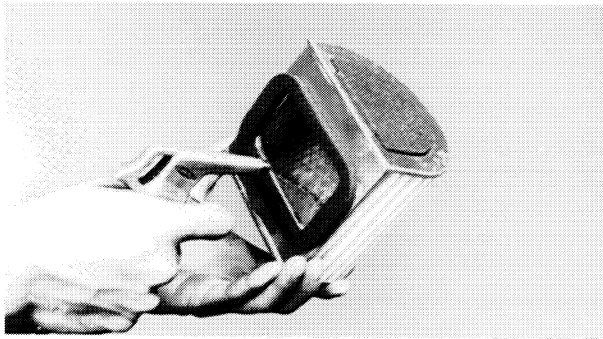

4. Clean:
 - Air filter elementBlow out dust in the element from the inner surface using compressed air.
5. Inspect:
 - Air filter elementDamage → Replace.
6. Install:
 - Air filter element
 - Air filter case cover (Left)
 - Side cover (Left)
 - Cover (Carburetor)

2

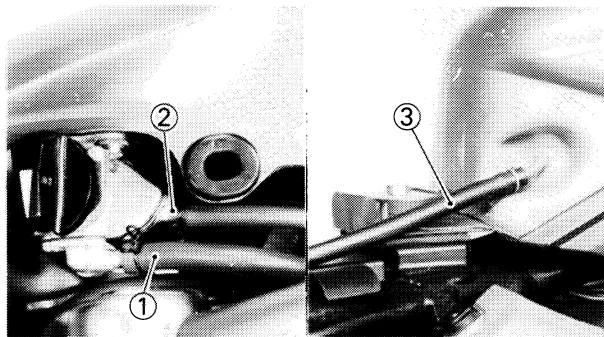
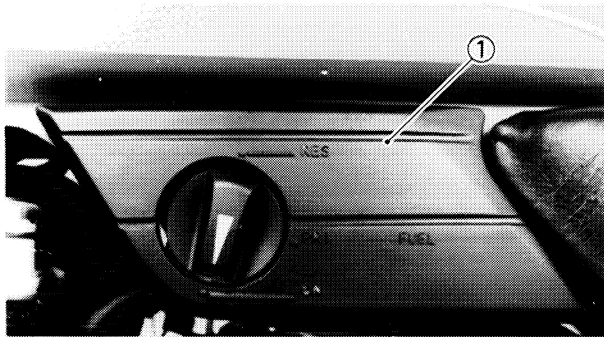

CHASSIS

FUEL COCK CLEANING

1. Turn the fuel cock to "ON" position.
2. Remove:
 - Cover (Fuel tank) ①
 - Seat
3. Disconnect:
 - Fuel pipe ①
 - Vacuum pipe ②
 - Fuel tank breather pipe ③
4. Remove:
 - Fuel tank
5. Drain
 - Fuel

WARNING:

FUEL IS HIGHLY FLAMMABLE:

- Always turn off the engine when draining.
- Take care not to spill any fuel on the engine or exhaust pipe/muffler when draining.
- Never drain fuel while smoking or in the vicinity an open flame.

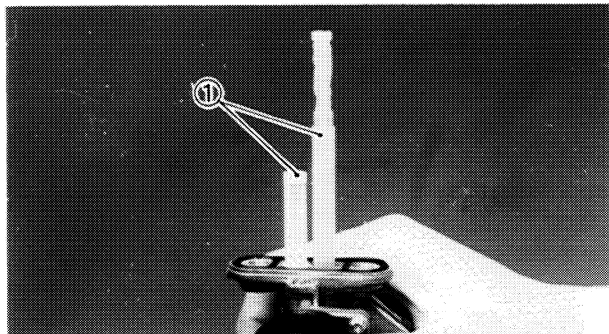

6. Remove:
 - Fuel cock
7. Clean:
 - Filter screen ①
Clean it with solvent.

8. Inspect:
 - Filter screen
 - O-ring
Damage → Replace.

9. Install:
 - Fuel cock
 - Fuel tank
 - Seat
 - Cover (Fuel tank)

NOTE:

Be careful not to clamp the fuel cock too tightly as this may unseat the O-ring and lead to a fuel leak.

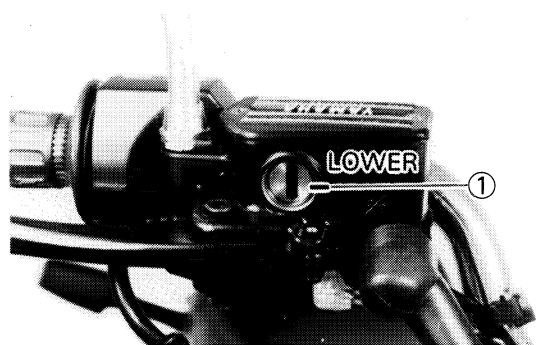

FRONT BRAKE FLUID INSPECTION

1. Inspect:
 - Brake fluid level
Fluid at lower level → Replenish.

① Front brake fluid lower level



Brake Fluid: DOT #3

FRONT BRAKE PAD INSPECTION/ FRONT BRAKE LEVER FREE PLAY ADJUSTMENT

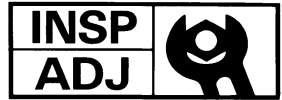

2

WARNING:

- Use only designated quality brake fluid to avoid poor brake performance.
- Refill with same type and brand of brake fluid; mixing fluids could result in poor brake performance.
- Be sure that water or other contaminants do not enter master cylinder when refilling.
- Clean up spilled fluid immediately to avoid erosion of painted surfaces or plastic parts.

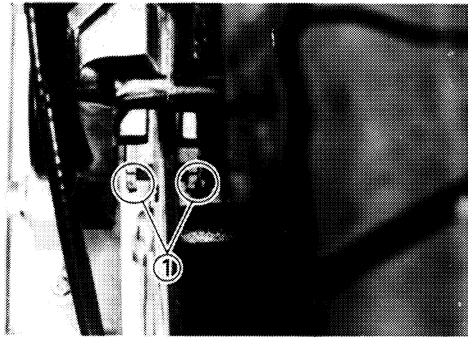

FRONT BRAKE PAD INSPECTION

1. Depress the brake lever.
2. Inspect:
 - Wear indicator ①
 - Indicator almost contacts disc → Replace pads.

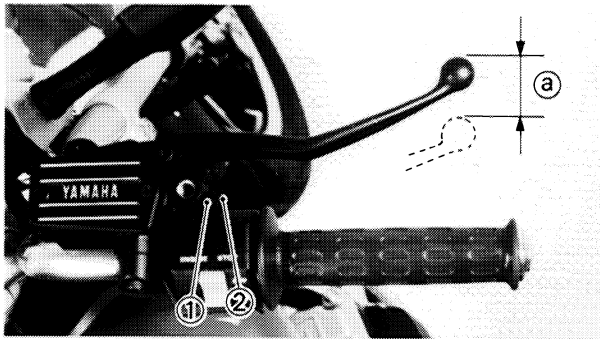

FRONT BRAKE LEVER FREE PLAY ADJUSTMENT

1. Loosen:
 - Locknut ①
2. Adjust:
 - Free play ②
 - Turn the adjuster ② in or out.

Turn in	Free play is decreased.
Turn out	Free play is increased.

	Free Play: 2 ~ 5 mm (0.08 ~ 0.20 in)
--	---

CAUTION:

Proper lever free play is essential to avoid excessive brake drag.

- Tighten:
 - Locknut

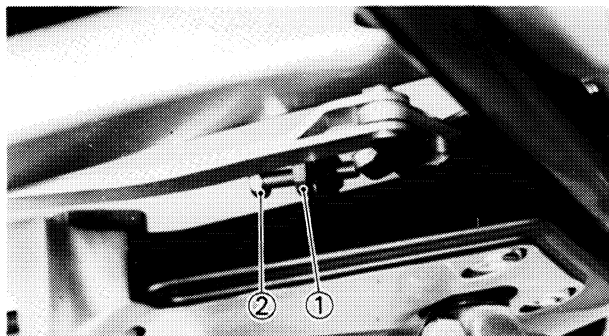

REAR BRAKE PEDAL HEIGHT ADJUSTMENT

- Loosen:
 - Locknut ①

② Adjuster

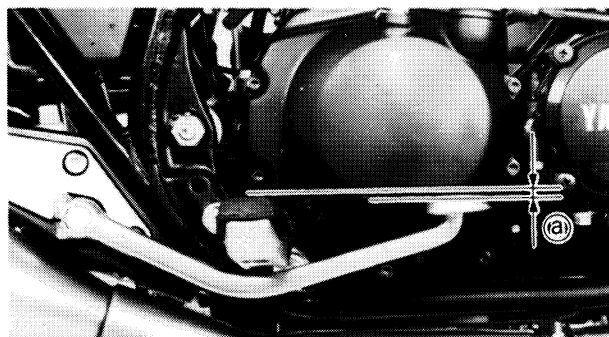

- Adjust:
 - Brake pedal height ③
 Turn the adjuster in or out.

Turn in	Pedal height is increased.
Turn out	Pedal height is decreased.



Pedal Height:
15 mm (0.6 in)
Below the top of the footrest.

WARNING:

After adjusting the pedal height, adjust brake pedal free play.

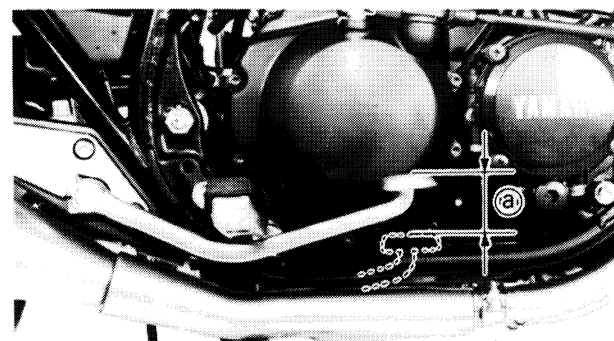

BRAKE PEDAL FREE PLAY ADJUSTMENT

- Adjust:
 - Free play ④
 Turn the adjuster ① in or out.

Turn in	Free play is decreased.
Turn out	Free play is increased.

REAR BRAKE LINING INSPECTION/ REAR BRAKE LIGHT SWITCH ADJUSTMENT

INSP
ADJ

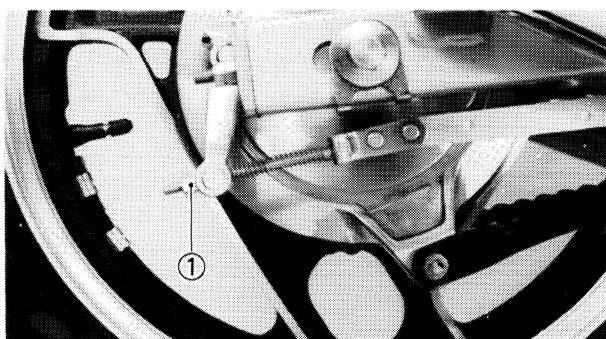

Free Play:
20 ~ 30 mm (0.8 ~ 1.2 in)

WARNING:

Check the operation of the brake light after adjusting the rear brake.

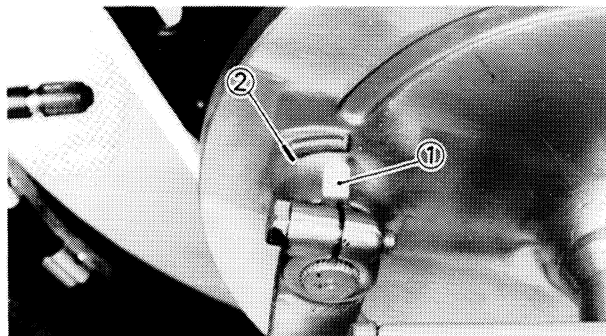

REAR BRAKE LINING INSPECTION

1. Depress the brake pedal.

2. Inspect:

- War indicator ①
 - Indicator reaches the wear limit line ② →
- Replace shoes.

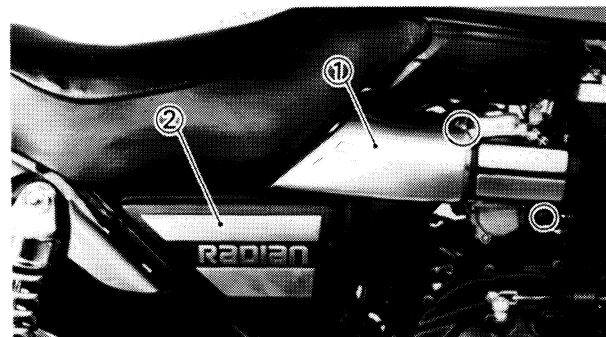

REAR BRAKE LIGHT SWITCH ADJUSTMENT

1. Remove:

- Cover (Carburetor) ①
- Side cover (Right) ②

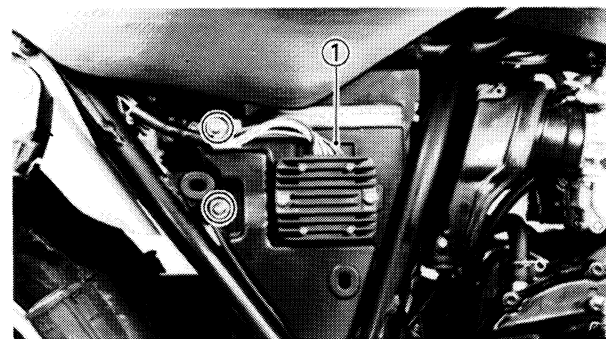

2. Remove:

- Battery case cover ①



3. Adjust:

- Rear brake light switch
- Hold the switch body ① with your hand so it does not rotate and turn the adjuster ②.

NOTE:

Proper adjustment is achieved when the brake light comes on just before the brake begins to take effect.

2

DRIVE CHAIN SLACK CHECK

NOTE:

Before checking and/or adjusting the chain slack, rotate the rear wheel through several revolutions. Check the chain slack several times to find the point where the chain is the tightest. Check and/or adjust the chain slack where the rear wheel is in this "tight chain" position.

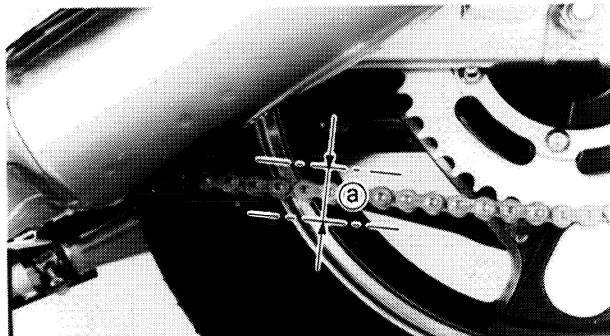

1. Place the motorcycle on the centerstand.
2. Measure:
 - Drive chain slack (a)
 Out of specification → Adjust.



Drive Chain Slack:
20 ~ 30 mm (0.8 ~ 1.2 in)

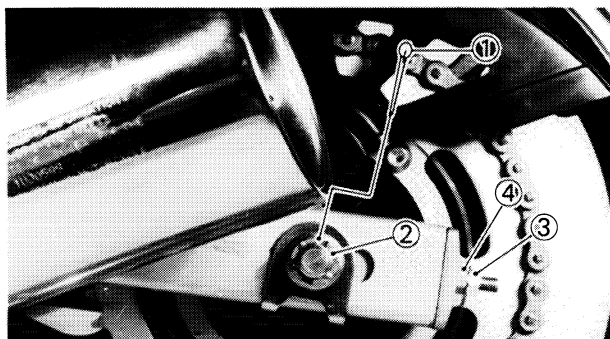

DRIVE CHAIN SLACK ADJUSTMENT

1. Remove:
 - Cotter pin (1)
2. Loosen:
 - Nut (Rear axle) (2)
 - Locknut (3)
3. Adjust:
 - Chain slack
 Turn the adjuster (4) in or out.

Turn in	Chain slack is decreased.
Turn out	Chain slack is increased.

NOTE:

There are marks on each side of rear arm and on each chain puller; use them to check for proper alignment.

CAUTION:

Too small chain slack will overload the engine and other vital parts; keep the slack within the specified limits.

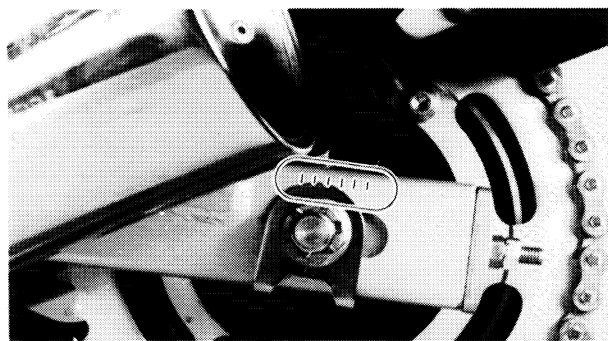

4. Tighten:
- Locknut
 - Nut (Rear axle)

	Nut (Rear Axle): 105 Nm (10.5 m•kg, 75 ft•lb)
---	---

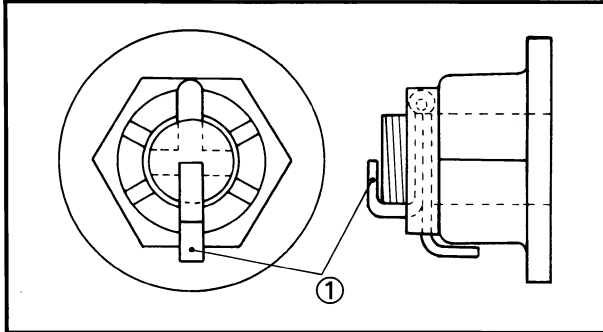

5. Install:
- Cotter pin ① (New)

NOTE: _____

Do not loosen the axle nut after torque tightening. If the axle nut groove is not aligned with the wheel shaft cotter pin hole, align groove to hole by tightening up on the axle nut.

2

DRIVE CHAIN LUBRICATION

The chain consists of many parts which work against each other. If the chain is not maintained properly, it will wear out rapidly, therefore, form the habit of periodically servicing the chain. This service is especially necessary when riding in dusty conditions.

	SAE 10W30 Motor Oil
---	----------------------------

CABLE INSPECTION AND LUBRICATION

Cable inspection and lubrication steps:

- Hold cable end high and apply several drops of lubricant to cable.
- Coat metal surface of disassembled throttle twist grip with suitable all-purpose grease to minimize friction.
- Check for damage to cable insulation. Replace any corroded or obstructed cables.
- Lubricate any cables that do not operate smoothly.

	Yamaha Chain and Cable Lube or SAE 10W30 Motor Oil
---	---

LEVER AND PEDAL LUBRICATION

Lubricate pivoting parts of each lever and pedal.

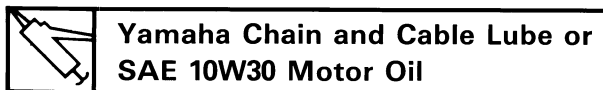

**CENTERSTAND AND SIDESTAND
LUBRICATION**

Lubricate centerstand and sidestand at their pivot points.

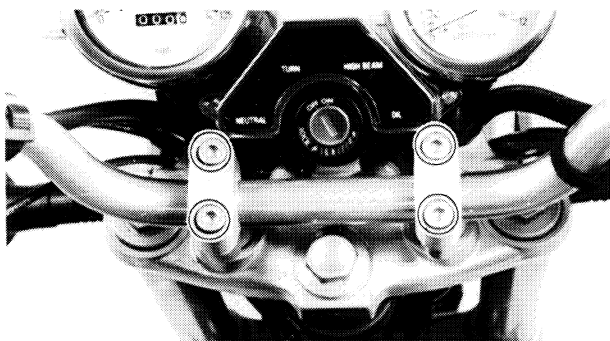
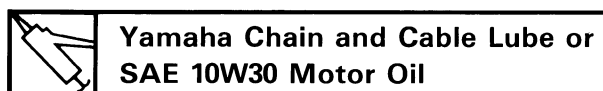

FRONT FORK OIL CHANGE

1. Place the motorcycle on the centerstand.

2. Remove:
• Handlebar

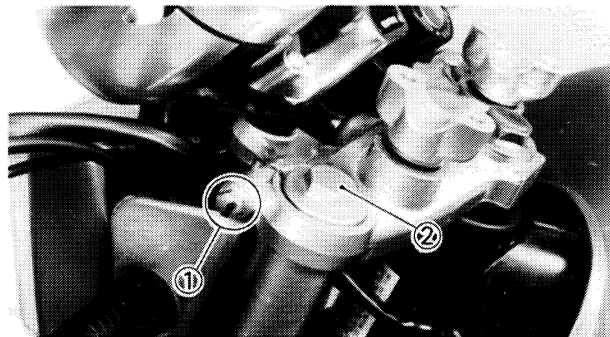

3. Loosen:
• Bolt ① (Handle crown)

4. Remove:
• Cap bolt ②

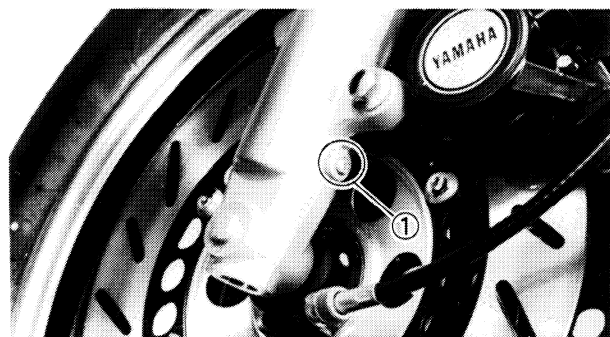

5. Place a receptacle under the drain hole.

6. Remove:
• Drain screw ①
Drain the fork oil

WARNING:

Do not allow any oil to contact the disc brake components. If oil is discovered, be sure to remove it, otherwise diminished braking capacity and damage to the rubber components of the brake assembly will occur.

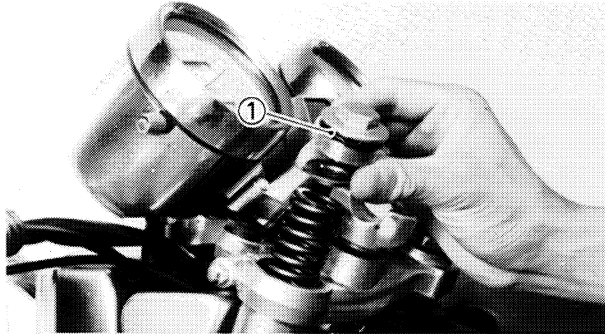

2

7. Inspect:

- O-ring (Cap bolt) ①
 - Gasket (Drain screw)
- Wear/Damage → Replace.

8. Install:

- Drain screw
- Gasket

9. Fill:

- Front fork

	<p>Recommended Oil: Yamaha Fork Oil 10WT or Equivalent For Oil Capacity (Each Fork): 320 cm³ (11.3 Imp oz, 10.8 US oz)</p>
--	--

10. After filling pump the forks slowly up and down to distribute the oil.

11. Tighten:

- Cap bolt
- Bolt (Handle crown)

	<p>Cap Bolt: 23 Nm (2.3 m•kg, 17 ft•lb) Bolt (Handle Crown): 23 Nm (2.3 m•kg, 17 ft•lb)</p>
---	--

12. Install:

- Handlebar

NOTE:

The upper handlebar holder should be installed with the punched mark ① forward.

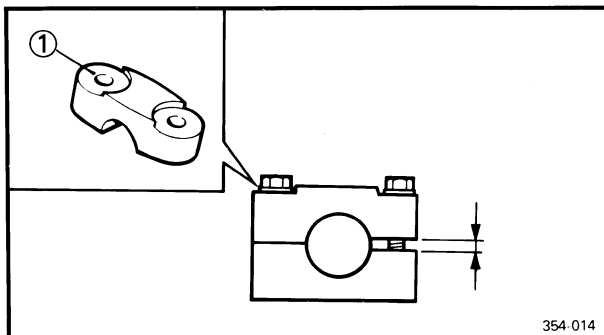

354-014

CAUTION:

First tighten the bolts on the front side of the handlebar holder, and then tighten the bolts on the rear side.



Bolt (Handlebar):
20 Nm (2.0 m•kg, 14 ft•lb)

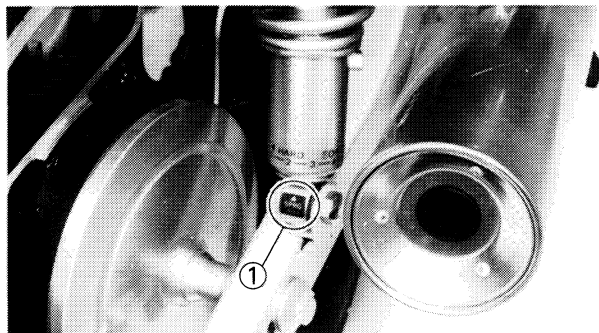

REAR SHOCK ABSORBER ADJUSTMENT

- Adjust:
 - Shock absorber preload

	← Stiffer			Std.	Softer
Adjusting position	5	4	3	2	1

- Match mark

WARNING:

Always adjust each shock absorber to the same setting. Uneven adjustment can cause poor handling and loss of stability.

Recommended Rear Shock Absorber Settings

Use this table as a guide for specific riding and motorcycle load conditions.

Rear shock absorber ◀ HARD SOFT ▶ 1 - 2 - 3 - 4 - 5 ▲ SPRING ADJUSTER	Loading condition			
	Solo rider	With passenger	With accessories and equipment	With accessories, equipment, and passenger
Position	1~2	3~5	3~5	5

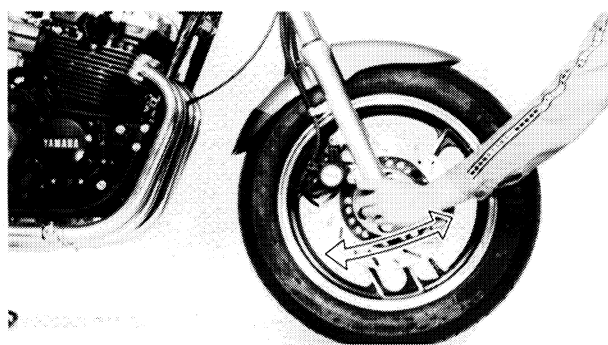

STEERING HEAD INSPECTION

- Place the motorcycle on its centerstand, then elevate the front wheel.
- Check:
 - Steering assembly bearings
 - Grasp the bottom of the forks and gently rock the fork assembly back and forth.
 - Looseness → Adjust steering head.

STEERING HEAD ADJUSTMENT/ FRONT WHEEL BEARING INSPECTION

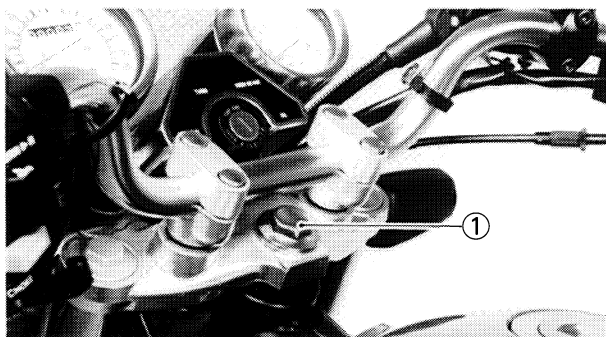

STEERING HEAD ADJUSTMENT

1. Loosen:
 - Bolt (Steering stem) ①

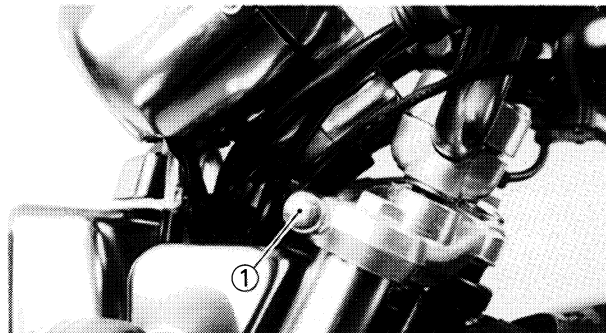

2. Loosen:
 - Bolts (Handle crown) ①

3. Lift the handle crown and handlebar assembly.

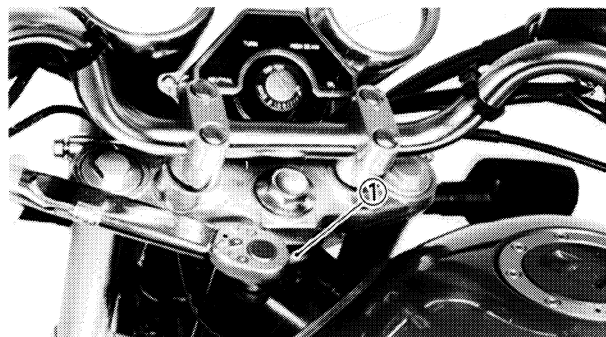

4. Tighten:
 - Ring nut
 - Use the Ring Nut Wrench ① (YU-33975).



Ring Nut:
38 Nm (3.8 m•kg, 27 ft•lb)

NOTE:

If steering is binded, loosen the ring nut so that there is no free play on bearing.

5. Install:
 - Handle crown



Bolt (Steering Stem):
54 Nm (5.4 m•kg, 39 ft•lb)
Bolt (Handle Crown):
20 Nm (2.0 m•kg, 14 ft•lb)

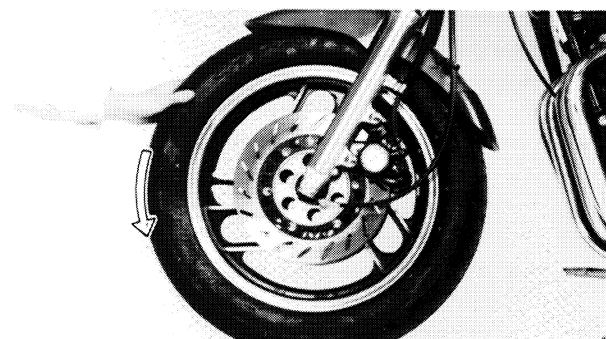

FRONT WHEEL BEARING INSPECTION

1. Raise the front end of the motorcycle, and spin the wheel by hand. Touch the axle or front fender while spinning the wheel. Excessive vibration → Replace bearings.

2



REAR WHEEL BEARING INSPECTION

1. Remove:
 - Cotter pin
 - Rear wheel

2. Check:
 - Bearing movement
With the fingers.
Roughness/Wear → Replace.

3. Install:
 - Rear wheel

4. Adjust:
 - Drive chain slack
Refer to "DRIVE CHAIN SLACK ADJUSTMENT" section.

5. Tighten:
 - Nut (Rear axle)

	Nut (Rear axle): 105 Nm (10.5 m•kg, 75 ft•lb)
---	--

6. Install:
 - Cotter pin (New)

TUBELESS TIRES AND ALUMINUM WHEELS INSPECTION

WARNING: _____

Do not attempt to use tubeless tires on a wheel designed for tube type tires only. Tire failure and personal injury may result from sudden deflation.

Wheel	Tire
Tube type	Tube type only
Tubeless	Tube type or tubeless

Be sure to install the correct tube when using tube type tires.

Always perform the following steps to ensure safe operation, maximum tire performance, and long service.

TUBELESS TIRES AND ALUMINUM WHEELS INSPECTION

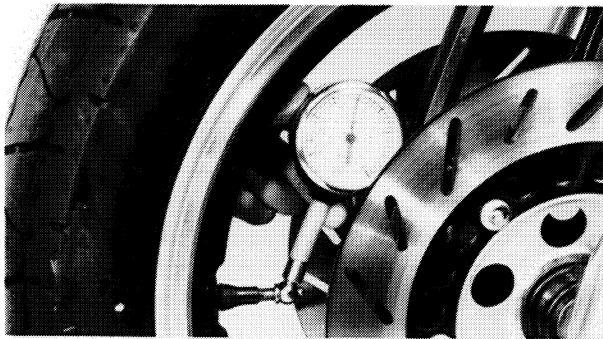

1. Measure:
 - Tire pressure
 - Out of specification → Adjust.

Basic weight: With oil and full fuel tank	197 kg (434 lb)	
Maximum load*	258 kg (569 lb)	
Cold tire pressure	Front	Rear
Up to 90 kg (198 lb) load*	177 kPa (1.8 kg/cm ² , 26 psi)	196 kPa (2.0 kg/cm ² , 28 psi)
90 kg (198 lb) ~ 160 kg (353 lb) load*	196 kPa (2.0 kg/cm ² , 28 psi)	226 kPa (2.3 kg/cm ² , 32 psi)
160 kg (353 lb) ~ Maximum load*	196 kPa (2.0 kg/cm ² , 28 psi)	245 kPa (2.5 kg/cm ² , 36 psi)
High speed riding	196 kPa (2.0 kg/cm ² , 28 psi)	226 kPa (2.3 kg/cm ² , 32 psi)

* Load is the total weight of cargo, rider, passenger, and accessories.

2

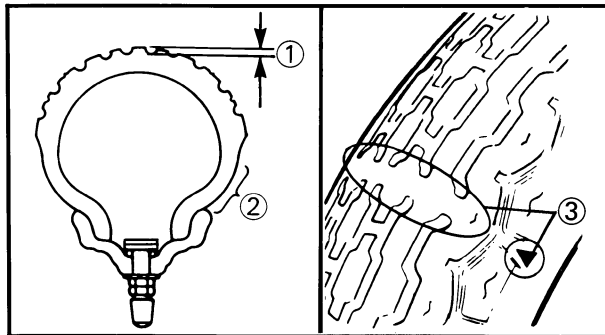

2. Inspect:
 - Tire surfaces
 - Wear/Damage → Replace.

	Minimum Tire Tread Depth:
	(Front and Rear) 0.8 mm (0.03 in)

- ① Tread depth
- ② Side wall
- ③ Wear indicator

3. Inspect:
 - Aluminum wheels
 - Damage/Bends → Replace.
 - Never attempt even small repairs to the wheel.

NOTE: _____

Always balance the wheel when a tire or wheel has been changed or replaced.



IGNITION TIMING CHECK

- Tighten:
 - Valve stem locknut



1.5 Nm (0.15 m•kg, 1.1 ft•lb)

WARNING:

Ride conservatively after installing a tire to allow it to seat itself properly on the rim.

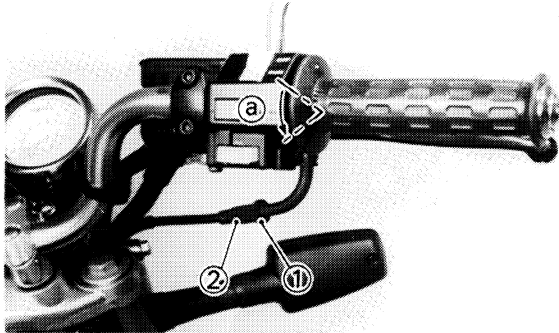

THROTTLE CABLE ADJUSTMENT

- Loosen:
 - Lock nut ①
- Adjust:
 - Throttle cable free play ②
 - Turn the adjuster ② in or out.

Turn in	Free play is increased.
Torn out	Free play is decreased.



Free play:
2~5 mm (0.08~0.20 in)

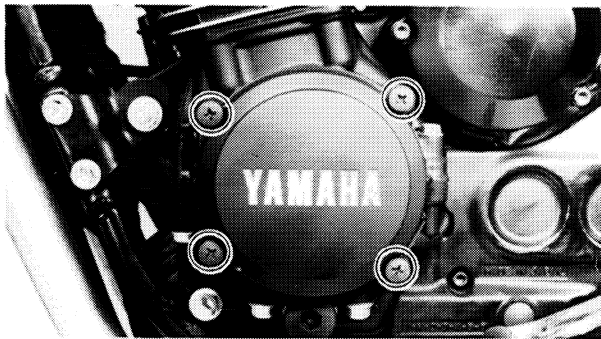

ELECTRICAL

IGNITION TIMING CHECK

- Remove:
 - Crankcase cover (Left)
- Connect:
 - Timing light (YM-33277)
(To the #1 spark plug lead)
- Warm up the engine and allow it to idle at the specified speed.

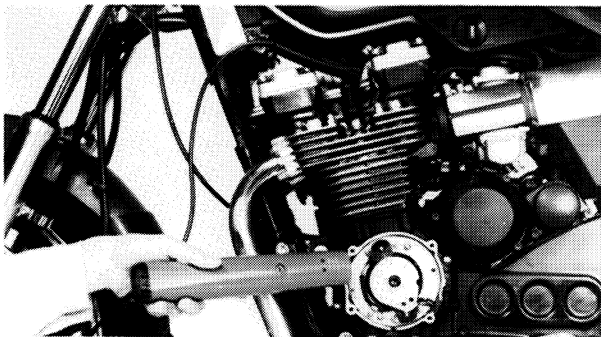

Engine Idle Speed:
1,250 ~ 1,350 r/min

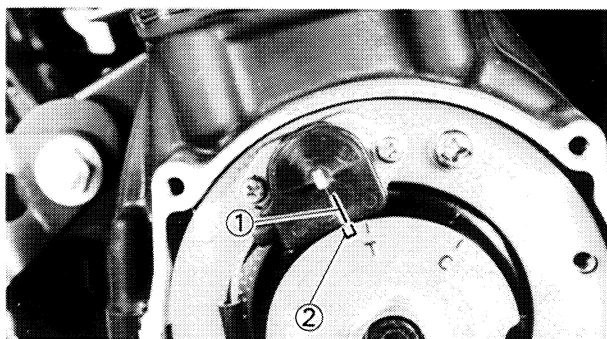

4. Check:

- Ignition timing

Visually check the upper pickup coil mark ① is within the firing range ② indicated on timing plate.

Incorrect firing range → Check flywheel and/or pickup assembly (tightness damage)
Refer to Chapter 6, "ELECTRICAL" for further information.

5. Install:

- Crankcase cover

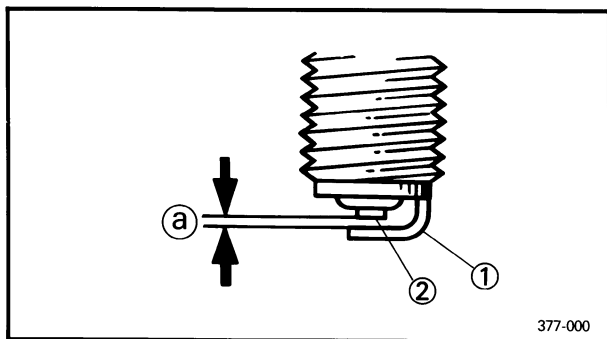

SPARK PLUG INSPECTION

1. Inspect:

- Electrode ①

Wear/Damage → Replace.

- Insulator color ②

Normal condition is a medium to light tan color.

Distinctly different color → Check the engine condition.

Ⓐ Spark plug gap

2. Clean:

- Spark plug

Clean the spark plug with a spark plug cleaner or wire brush.

3. Inspect:

- Spark plug type

Incorrect → Replace.

Standard Spark Plug:

D8EA (NGK), X24ESU (N.D.)

4. Measure:

- Spark plug gap

Out of specification → Regap.

Use a wire gauge.



Spark Plug Gap:

0.6 ~ 0.7 mm (0.024 ~ 0.028 in)

5. Tighten:
 - Spark plug

NOTE: _____

Before installing a spark plug, clean the gasket surface and plug surface.

	Spark Plug: 18 Nm (1.8 m•kg, 13 ft•lb)
---	---

NOTE: _____

If a torque wrench is not available when you are installing a spark plug, a good estimate of the correct torque is 1/4 to 1/2 turns part finger tight. Have the spark plug torqued to the correct value as soon as possible with a torque wrench.

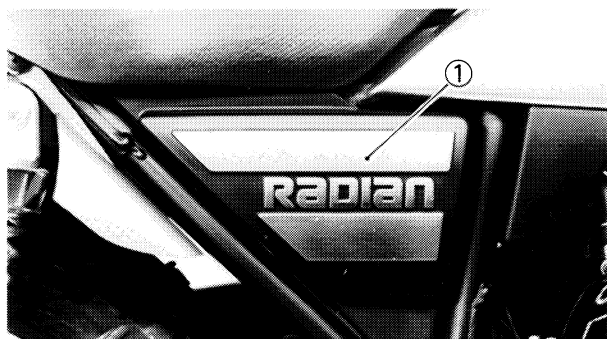

BATTERY INSPECTION

1. Remove:
 - Side cover (Right) ①



2. Inspect:
 - Fluid level should be between upper ① and lower ② level marks.
 - Incorrect → Refill.

CAUTION: _____

Refill with distilled water only; tap water contains minerals harmful to a battery.

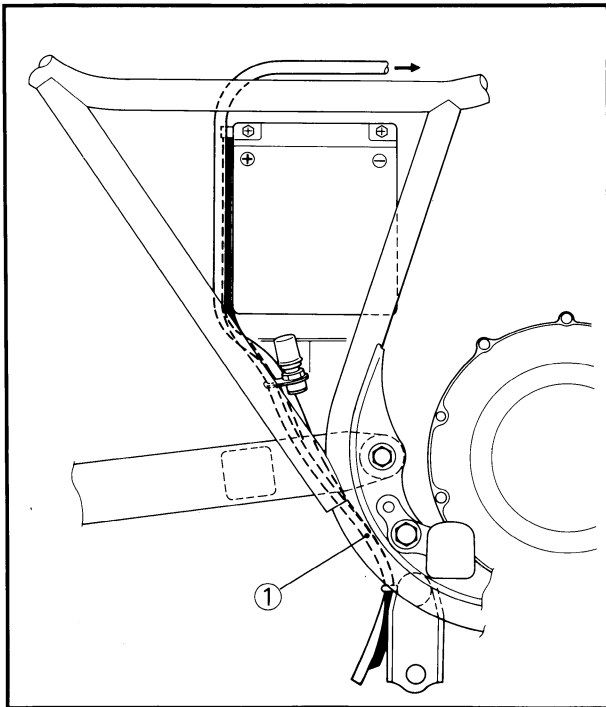

3. Connect:

- Breather pipe ①

Be sure the hose is properly attached and routed.

4. Inspect:

- Breather pipe
Obstruction → Remove.
Damage → Replace.

CAUTION: _____

When inspecting the battery, be sure the breather pipe is routed correctly. If the breather pipe touches the frame or exits in such a way as to cause battery electrolyte or gas to exit onto the frame, structural and cosmetic damage to the motorcycle can occur.

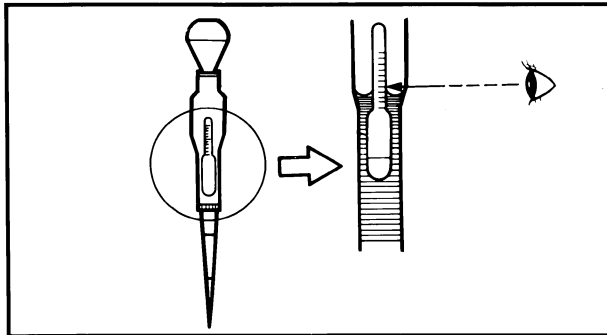

5. Check:

- Specific gravity:
Less than 1.280 → Recharge battery.

Charging Current:

1.2 amps/10 hrs

Specific Gravity:

1.280 at 20°C (68°F)

Replace the battery if:

- Battery voltage will not rise to a specific value or bubbles fail to rise even after many hours of charging.
- Sulfation of one or more cells occurs, as indicated by the plates turning white, or an accumulation of material exists in the bottom of the cell.
- Specific gravity readings after a long, slow charge indicate one cell to be lower than the rest.
- Warpage or buckling of plates or insulators is evident.

CAUTION: _____

Always charge a new battery before using it to ensure maximum performance.



WARNING:

Battery electrolyte is dangerous; it contains sulfuric acid and therefore is poisonous and highly caustic.

Always follow these preventive measures:

- Avoid bodily contact with electrolyte as it can cause severe burns or permanent eye injury.
- Wear protective eye gear when handling or working near batteries.

Antidote (EXTERNAL):

- SKIN – Flush with water.
- EYES – Flush with water for 15 minutes and get immediate medical attention.

Antidote (INTERNAL):

- Drink large quantities of water or milk follow with milk of magnesia, beaten egg, or vegetable oil. Get immediate medical attention.

Batteries also generate explosive hydrogen gas, therefore you should always follow these preventive measures:

- Charge batteries in a well-ventilated area.
- Keep batteries away from fire, sparks, or open flames (e.g., welding equipment, lighted cigarettes, etc.)
- DO NOT SMOKE when charging or handling batteries.

KEEP BATTERIES AND ELECTROLYTE OUT OF REACH OF CHILDREN.

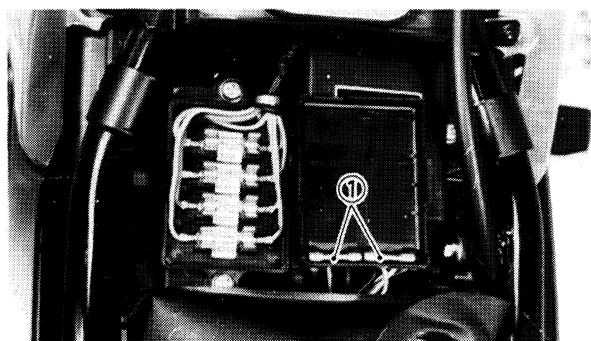

FUSE INSPECTION

The fuse panel is located under the seat.

1. Inspect:

- Fuses
 - Defective → Replace.
 - Blown fuse (New) → Inspect circuit.

NOTE:

Install new fuses of proper amperage.

- ① Spare fuses

Description	Amperage	Quantity
Main	20A	1
Headlight	10A	1
Signal	10A	1
Ignition	10A	1
Reserve	10A	1
	20A	1

Blown fuse replacement steps:

- Turn off ignition and the circuit.
- Install a new fuse of proper amperage.
- Turn on switches to verify operation of electrical device.
- If fuse blows immediately again, check circuit in question.

2

WARNING:

Do not use fuses of higher amperage rating than recommended. Extensive electrical system damage and fire could result from substitution of a fuse of improper amperage.

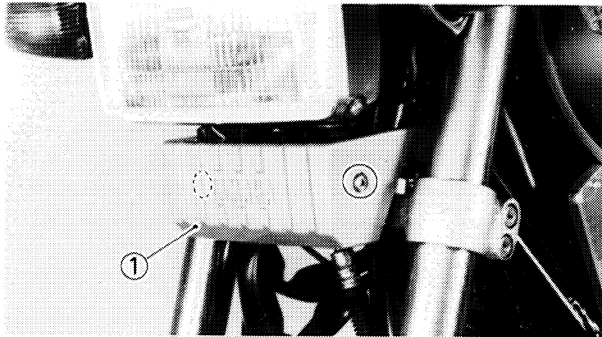

HEADLIGHT BEAM ADJUSTMENT

1. Remove:

- Cover ①

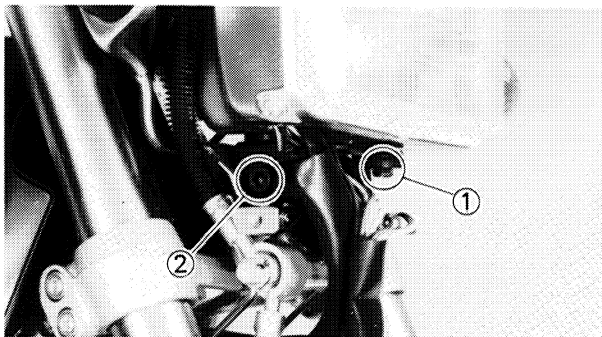

2. Adjust:

- Horizontal beam direction
Loosen the adjusting screw ① and move the headlight body right or left.
When proper adjustment is achieved, retighten the adjusting screw.

3. Adjust:
 - Vertical beam direction
Loosen the adjusting screw ② and move the headlight body up or down.
When proper adjustment is achieved, retighten the adjusting screw.

4. Install:
 - Cover

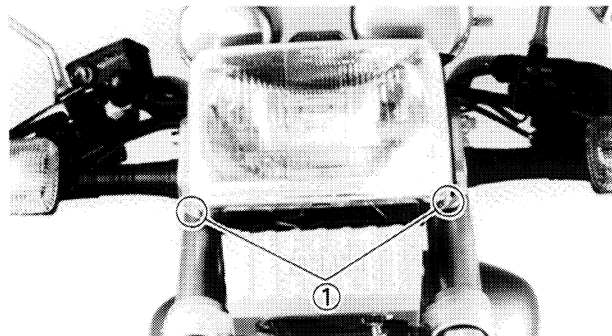

HEADLIGHT BULB REPLACEMENT

1. Remove:
 - Screw ①
2. Disconnect:
 - Headlight leads

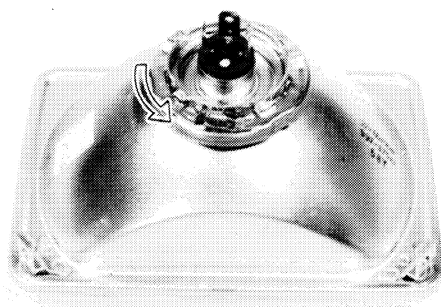

3. Remove:
 - Bulb
Turn the bulb holder counterclockwise to release bulb.

WARNING: _____

Keep flammable products or your hands away from the bulb while it is on, it will be hot. Do not touch the bulb until it cools down.

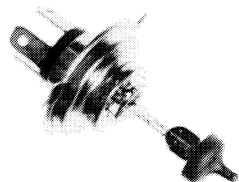

4. Install:
 - Bulb (New)
Secure the new bulb with the bulb holder.

CAUTION: _____

Avoid touching glass part of bulb. Also keep it free from oil otherwise, transparency of glass, bulb life and illuminous flux will be adversely affected. If oil gets on bulb, clean it with a cloth moistened thoroughly with alcohol or lacquer thinner.

5. Install:
 - Headlight lens unit

TAILLIGHT BULB REPLACEMENT

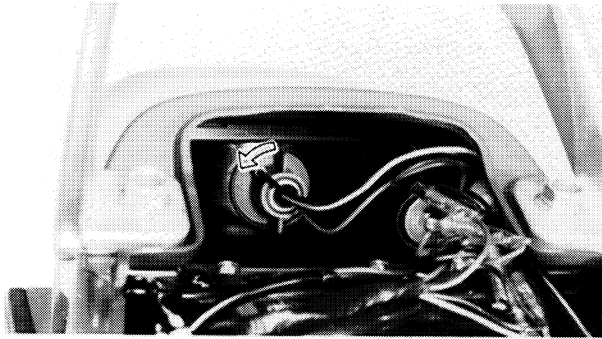

TAILLIGHT BULB REPLACEMENT

1. Remove:
 - Seat

2. Remove:
 - Bulb socket
Turn the bulb socket approximately 30° counterclockwise.

3. Replace:
 - Defective bulb

4. Install:
 - Bulb socket
 - Seat

2

CARBURETOR AIR VENT SYSTEM INSPECTION (CALIFORNIA ONLY)

1. Inspect:
 - Hoses
 - Air vent control valveRefer to "CHAPTER 6-CARBURETOR AIR VENT SYSTEM" section.



MEMO



CHAPTER 3 ENGINE OVERHAUL

ENGINE REMOVAL	3-1
PREPARATION FOR REMOVAL	3-1
SEAT AND FUEL TANK	3-2
CARBURETOR	3-3
EXHAUST PIPES AND MUFFLERS	3-5
DRIVE CHAIN	3-5
CABLE AND PIPE	3-6
LEADS	3-6
CANISTER (CALIFORNIA ONLY)	3-7
ENGINE REMOVAL	3-7
 ENGINE DISASSEMBLY	 3-8
CYLINDER HEAD AND CAMSHAFT	3-8
PISTON AND INTAKE SIDE CAM CHAIN GUIDE	3-10
PICKUP COIL AND GENERATOR	3-11
CLUTCH	3-12
OIL PUMP AND SHIFT SHAFT	3-13
CRANKCASE DISASSEMBLY	3-14
UPPER CRANKCASE	3-15
LOWER CRANKCASE	3-16
 INSPECTION AND REPAIR	 3-17
CYLINDER HEAD	3-17
VALVE, VALVE GUIDE, VALVE SEATS AND VALVE SPRING	3-18
CAMSHAFT, CAM CHAIN AND CAM SPROCKET	3-25
CYLINDER	3-27
PISTON, PISTON RING AND PISTON PIN	3-28
CRANKSHAFT AND CONNECTING ROD	3-31
OIL PUMP	3-35
PRIMARY DRIVE	3-36
STARTER DRIVES	3-36
CLUTCH	3-37
TRANSMISSTION	3-39
HY-VO CHAIN GUIDE AND TENSIONER	3-40
RELIEF VALVES	3-40
CRANKCASE	3-40
BEARINGS AND OIL SEALS	3-41
CIRCLIPS AND WASHERS	3-41

ENGINE ASSEMBLY AND ADJUSTMENT	3-44
LOWER CRANKCASE.....	3-44
UPPER CRANKCASE	3-48
CRANKCASE ASSEMBLY	3-49
OIL PUMP AND SHIFT SHAFT	3-54
CLUTCH	3-56
PICKUP COIL AND GENERATOR	3-60
PISTON AND INTAKE SIDE CAM CHAIN GUIDE	3-62
CYLINDER.....	3-64
CYLINDER HEAD.....	3-66
CAMSHAFT	3-68
REMOUNTING ENGINE	3-73



ENGINE OVERHAUL

ENGINE REMOVAL

NOTE:

It is not necessary to remove the engine in order to remove the following components:

- Cylinder head
- Cylinder
- Piston
- Clutch
- AC magneto

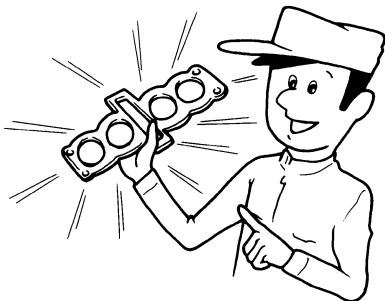
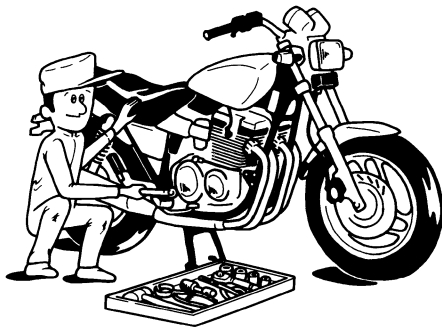
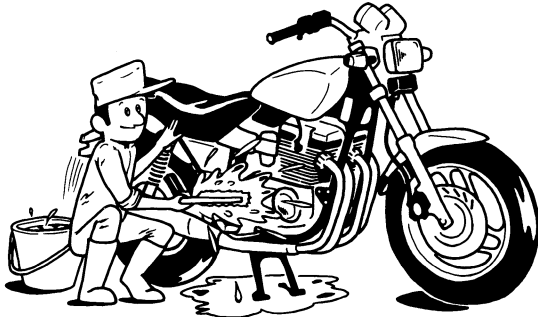

PREPARATION FOR REMOVAL

1. Remove all dirt, mud, dust and foreign material before removal and disassembly.
2. Use proper tools and cleaning equipment. Refer to "CHAPTER 1. GENERAL INFORMATION-SPECIAL TOOLS" section.

NOTE:

When disassembling the engine, keep mated parts together. This includes gears, cylinder, piston and other parts that have been "mated" through normal wear. Mated parts must be reused as an assembly or replaced.

3. During engine disassembly, clean all parts and place them in trays in the order of disassembly. This will speed up assembly time and help assure that all parts are correctly reinstalled in the engine.



4. Start the engine and allow it to warm up.
5. Drain the transmission oil completely. Refer to "CHAPTER 2. PERIODIC INSPECTIONS AND ADJUSTMENTS—ENGINE OIL REPLACEMENT" section.

SEAT AND FUEL TANK

1. Place the motorcycle on its centerstand.
2. Turn the fuel cock to "ON" position.

3. Remove:

- Seat
- Cover (Fuel cock) ①

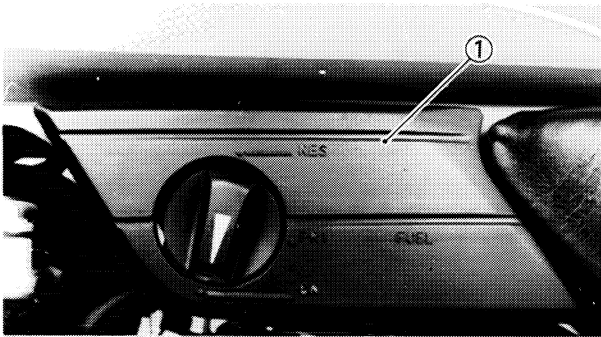

4. Remove:

- Cover (Carburetor)

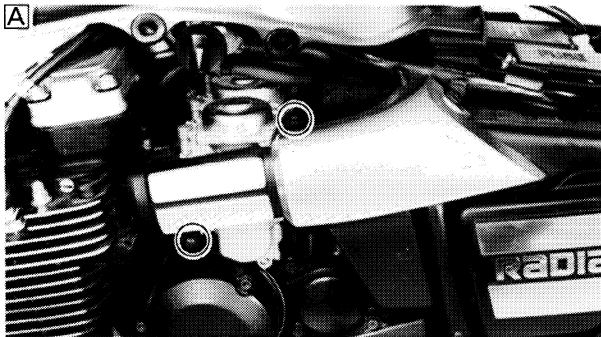

- A** Left side
- B** Right side

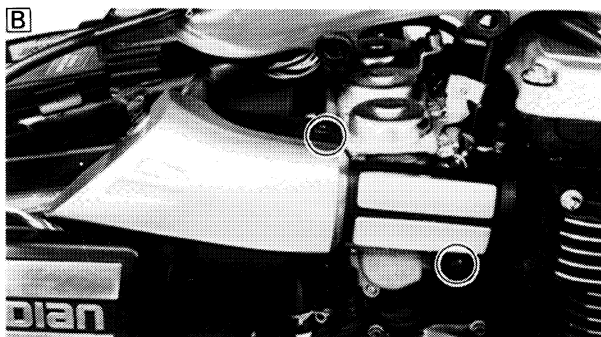

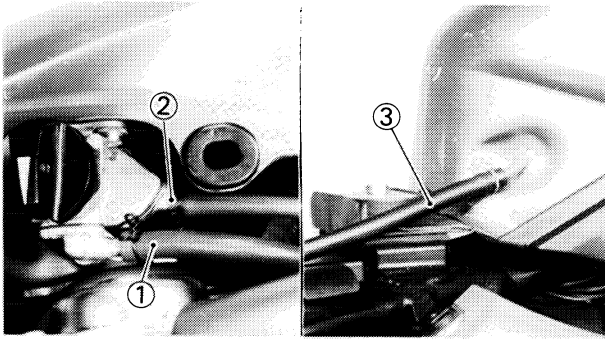

5. Disconnect:
- Fuel pipe ①
 - Vacuum pipe ②
 - Fuel tank breather pipe ③

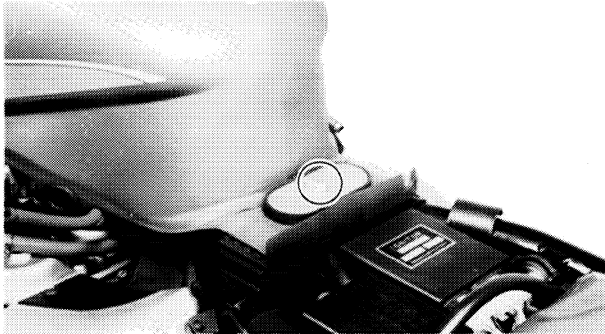

6. Remove:
- Fuel tank

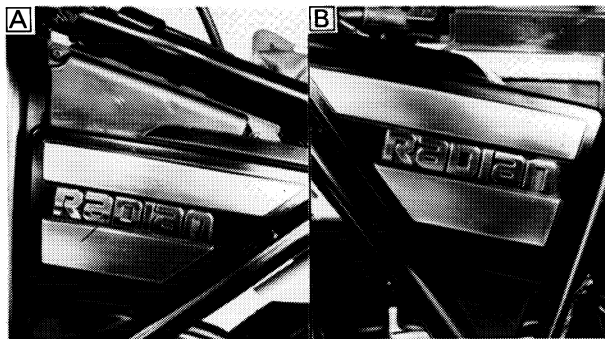
**CARBURETOR**

1. Remove:
- Side cover

- A** Left side
B Right side

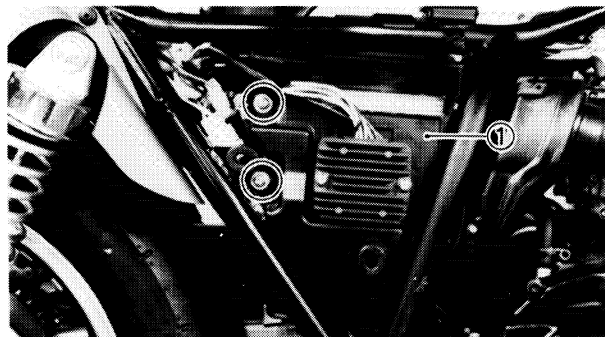

2. Remove:
- Battery case cover ①
 - Battery

CAUTION:

Disconnect the negative lead first, and then disconnect the positive lead.

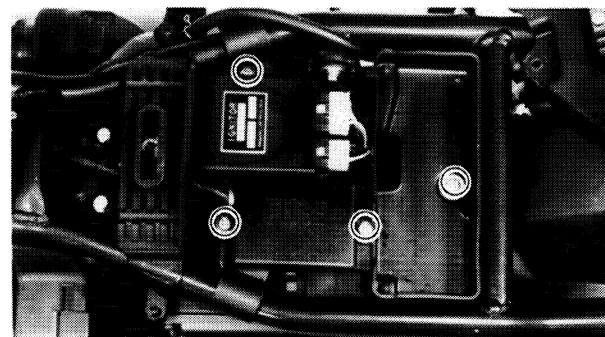

3. Remove:
- Screws (Fuse box)
 - Ignitor unit

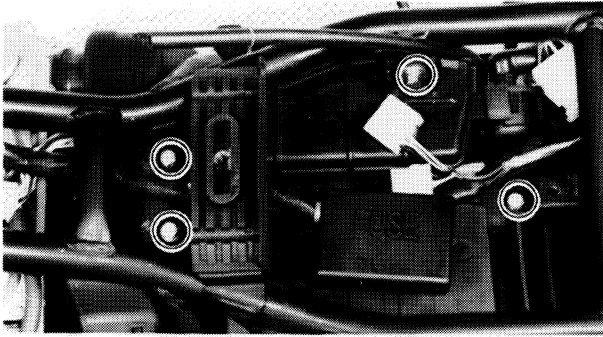

4. Remove:
- Bolts (Air cleaner case)
 - Bolts (Battery case)

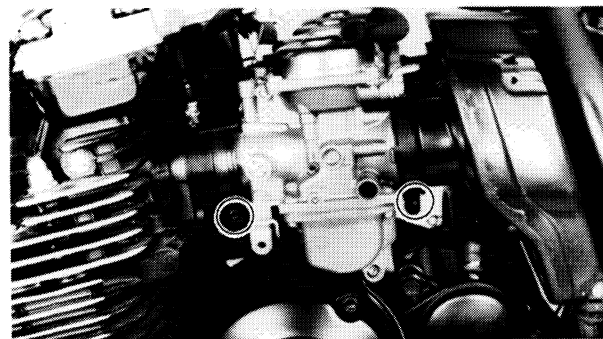
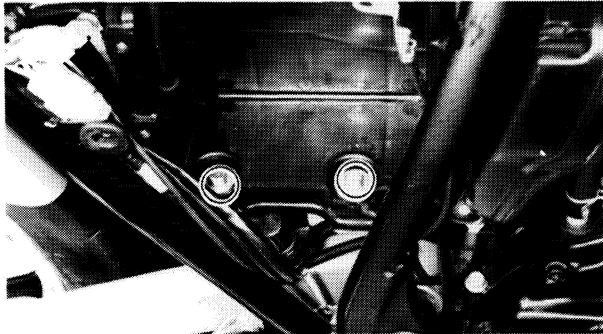

5. Loosen:
- Screws (Carburetor joints)

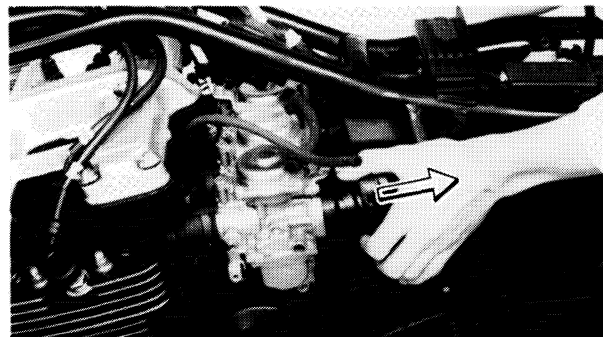

6. Slide the air cleaner case and the battery case backward.

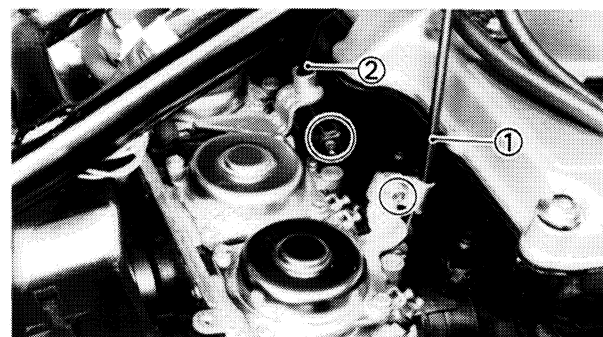

7. Remove:
- Starter cable ①
 - Throttle cable ②
 - Air vent hoses
 - Carburetor assembly

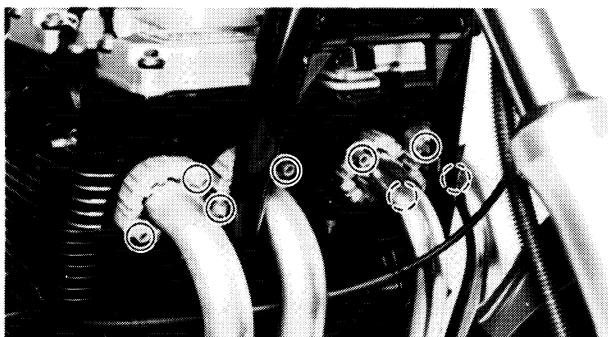
**EXHAUST PIPES AND MUFFLERS**

1. Remove:
 - Nuts (Exhaust pipes)

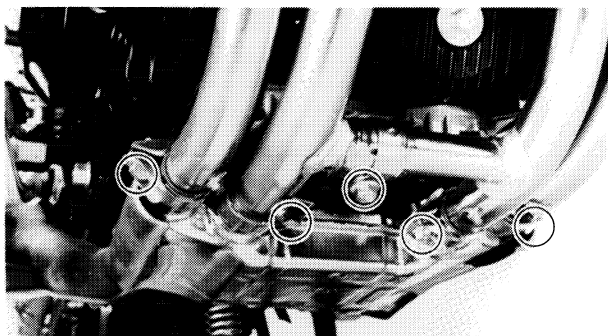

2. Loosen:
 - Bolts (Exhaust pipes)

3. Remove:
 - Exhaust pipes

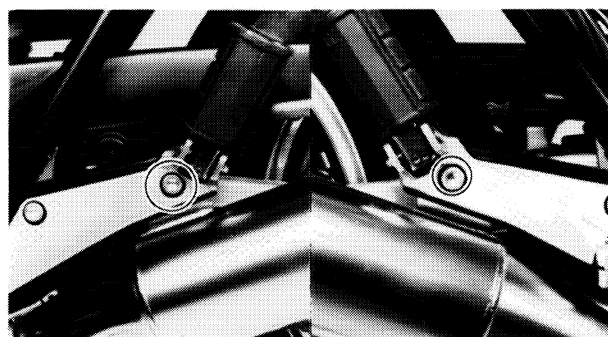

4. Remove:
 - Mufflers

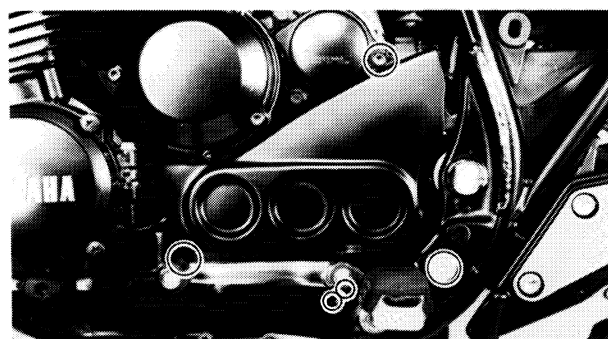
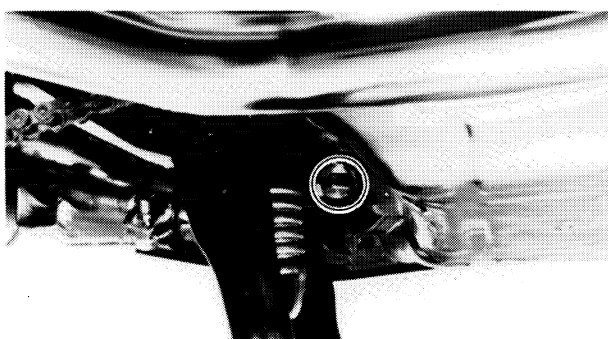
**DRIVE CHAIN**

1. Remove:
 - Footrest (Left)
 - Change pedal
 - Drive sprocket cover

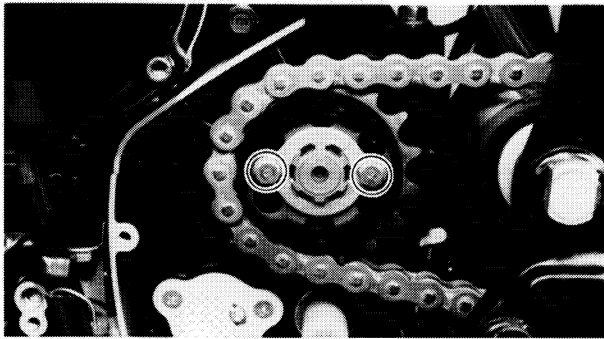

2. Remove:
 - Drive sprocket
 - Drive chain

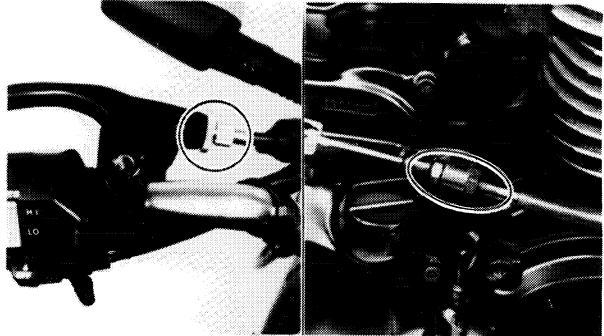

CABLE AND PIPE

1. Loosen:
 - Adjusters (clutch cable)
2. Remove:
 - Clutch cable

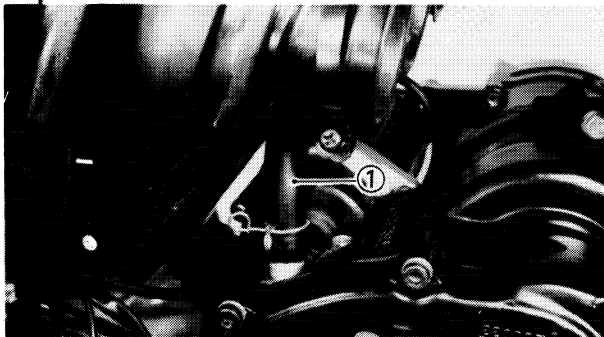

3. Disconnect:
 - Crankcase ventilation hose ①

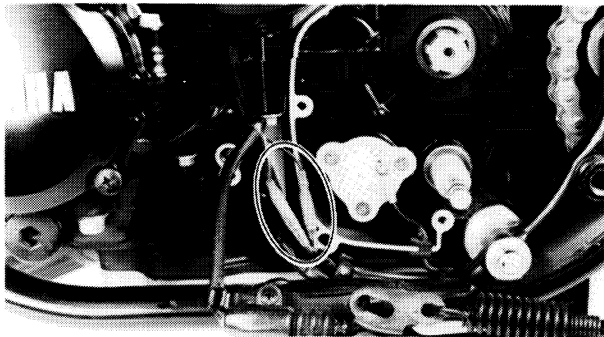

LEADS

1. Disconnect:
 - Sidestand switch leads

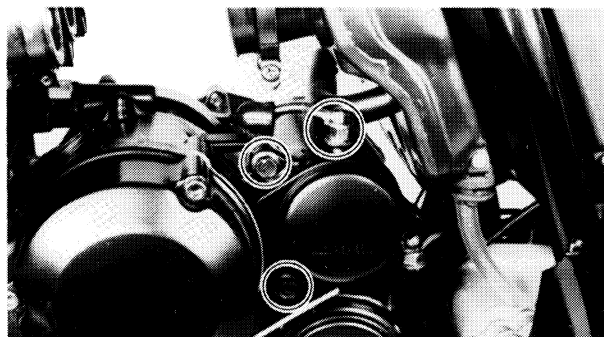

2. Remove:
 - Starter motor lead
 - Starter motor

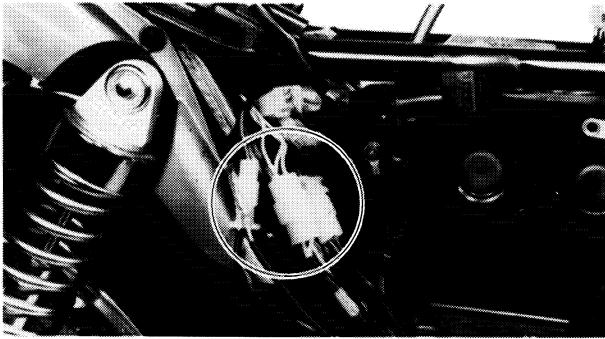

3. Disconnect:
 - Pickup coil leads
 - Oil level switch leads
 - Neutral switch leads
 - AC magneto leads

4. Remove:
 - Spark plug leads

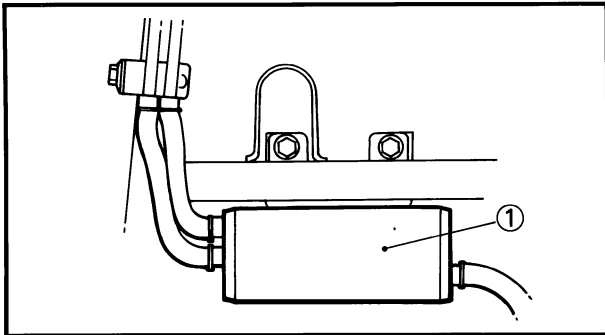
**CANISTER (CALIFORNIA ONLY)**

1. Remove:
 - Canister ①
(at front of the engine)

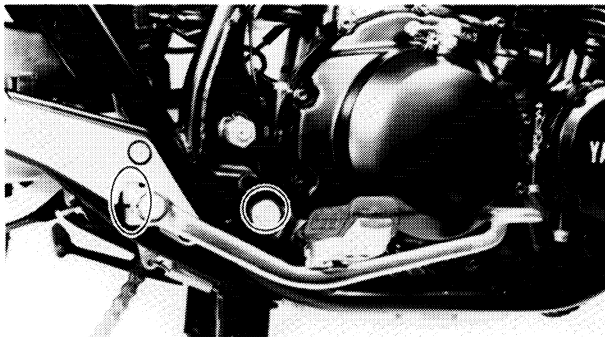
**ENGINE REMOVAL**

1. Remove:
 - Footrest (Right)
 - Brake pedal

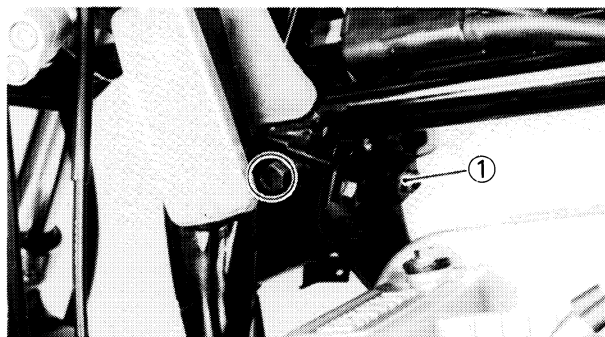

2. Remove:
 - Horn ①

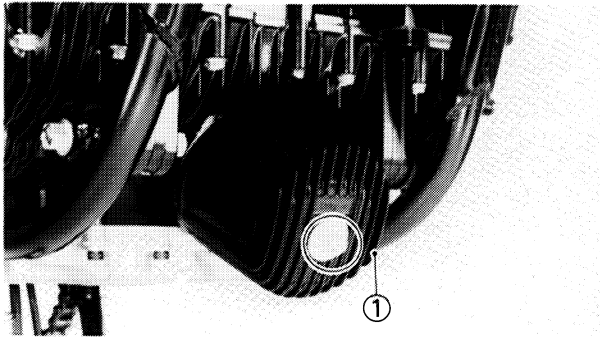

3. Remove:
 - Oil filter ①

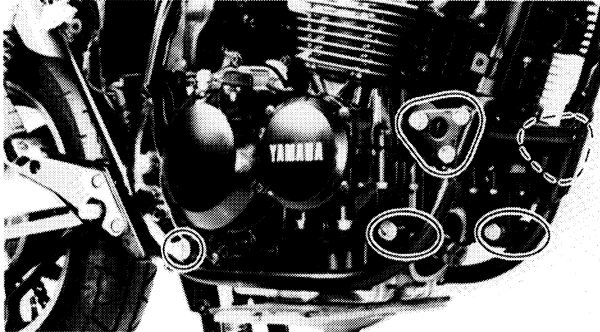

4. Place a suitable stand under the engine.

5. Remove:
 - Mounting bolts
 - Engine assembly (from right chassis)

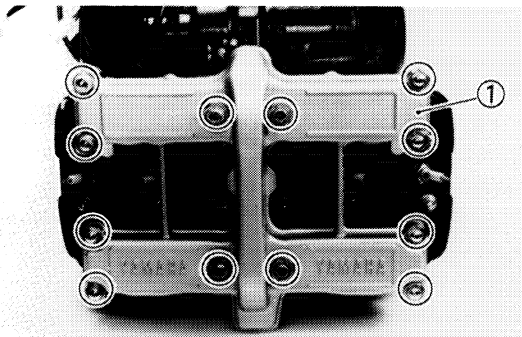

ENGINE DISASSEMBLY CYLINDER HEAD AND CAMSHAFT

1. Remove:
 - Cylinder head cover ①
 - Spark plugs

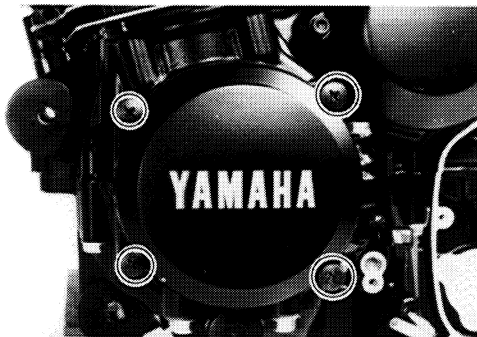

2. Remove:
 - Crankcase cover (Left)

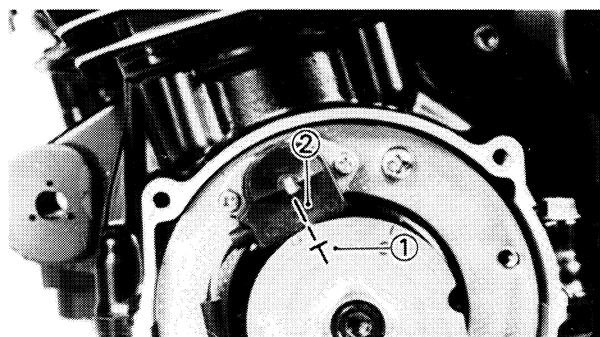

3. Turn:
 - Crankshaft (Counterclockwise)
4. Align:
 - Timing plate "T" mark ① (with the upper pickup coil mark ②)

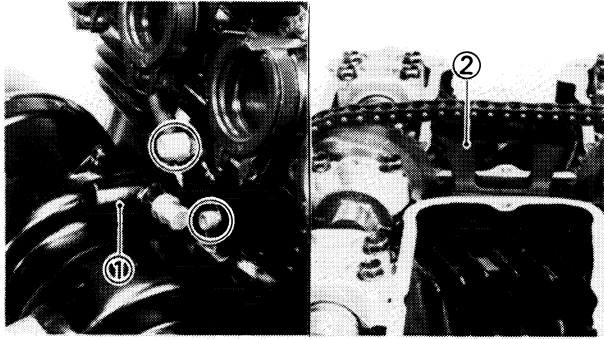

5. Remove:

- Tensioner assembly (1)
- Upper chain guide (2)

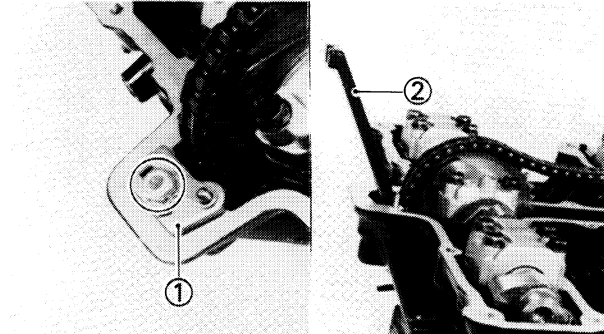

6. Remove:

- Chain guide stopper (1)
- Chain guide (Exhaust side) (2)

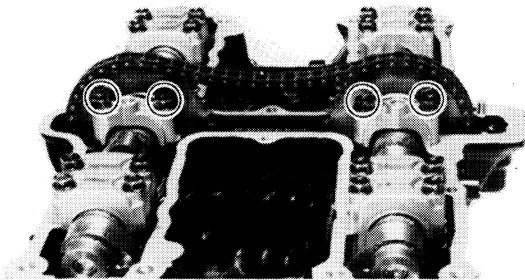

7. Remove:

- Intake cam cap (#3)
- Exhaust cam cap (#3)

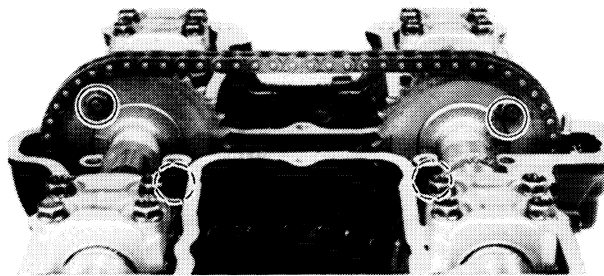

8. Remove:

- Bolts (Camshaft sprocket)

9. Dismount the sprockets from camshaft sprocket seats.

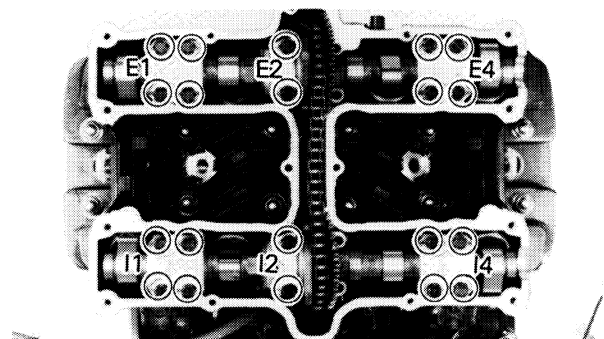

10. Remove:

- Cam caps
- Dowel pins

CAUTION:

Do not rotate the camshaft or valve damage may occur.

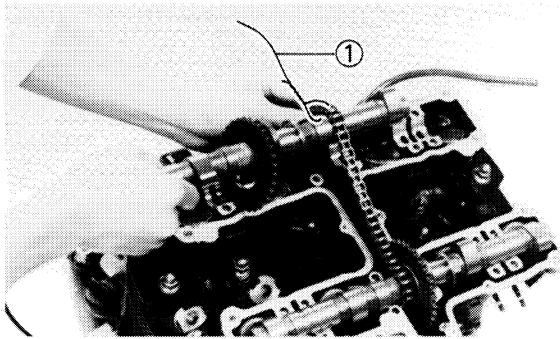

11. Remove:
- Camshafts

NOTE: _____

Fasten safety wire (1) to the cam chain to prevent it from falling into the crankcase.

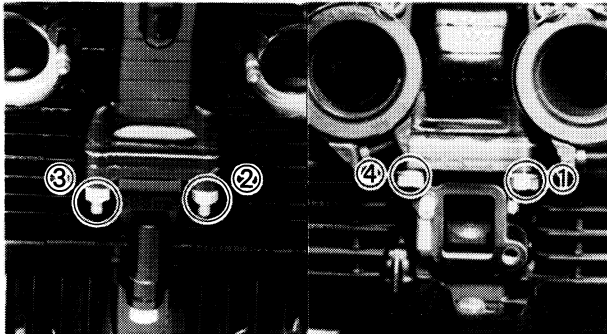

12. Remove:
- Cylinder head

NOTE: _____

Loosen the nuts in their proper loosening sequence.

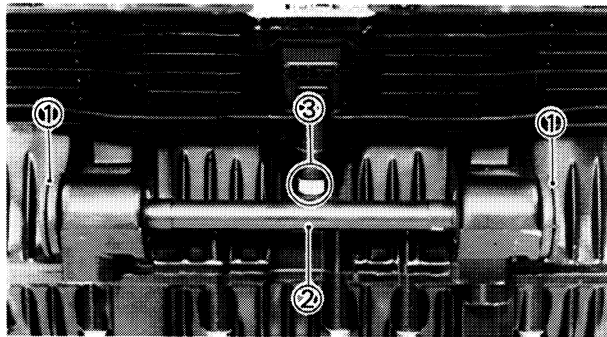
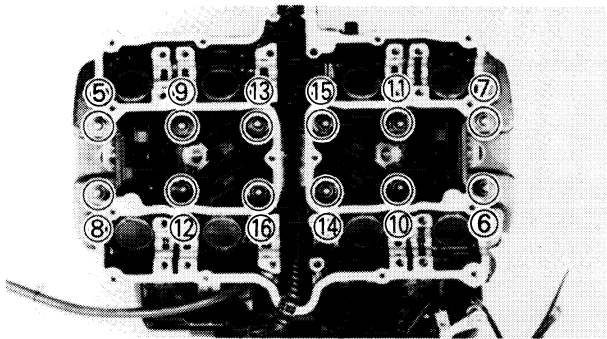

13. Remove:
- Damper (1)
 - Front engine mount spacer (2)
 - Nut (3)
 - Cylinder

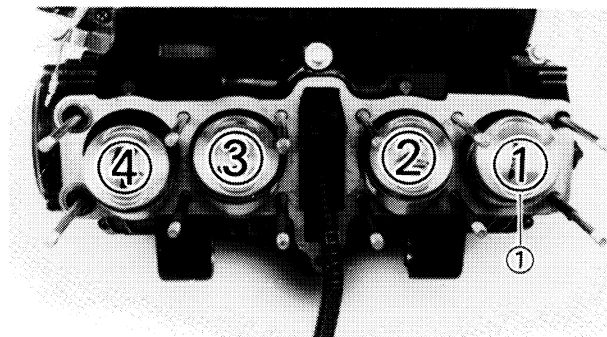

PISTON AND INTAKE SIDE CAM CHAIN GUIDE

1. Mark:
- Pistons
(with piston number (1) designations as shown.)

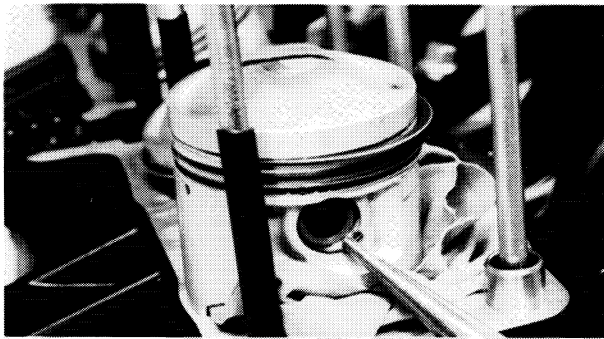

2. Remove:
 - Piston pin circlips

NOTE: _____
 Before removing piston pin circlip, cover crankcase with a clean rag to prevent circlip from falling into crankcase cavity.

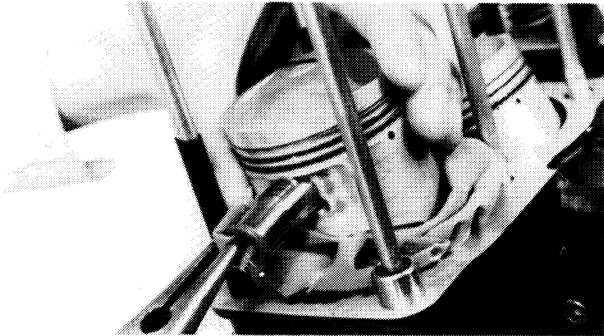

3. Remove:
 - Piston pins
 - Pistons

NOTE: _____
 Before removing the piston pin, deburr the clip grooved and pin hole area. If the piston pin groove is deburred and piston pin is still difficult to remove, use Piston Pin Puller (YU-01304).

CAUTION: _____
 Do not use a hammer to drive the piston pin out.

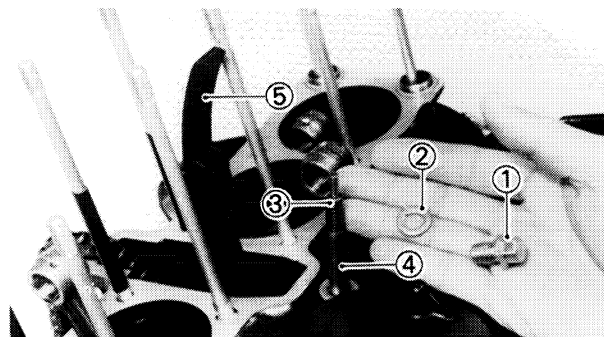

4. Remove:
 - Bolt ①
 - Plate washer ②
 - Spring ③
 - Stopper shaft ④
 - Intake side cam chain guide ⑤

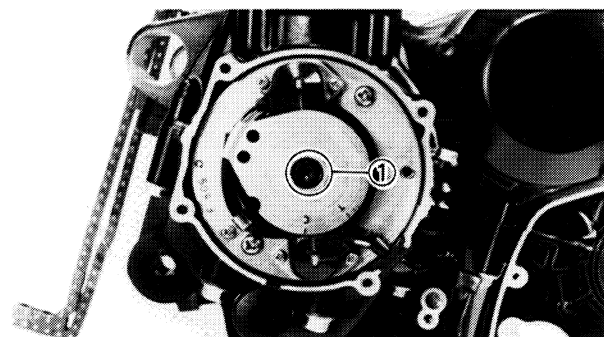

PICKUP COIL AND GENERATOR

1. Remove:
 - Bolt ① (Timing plate)

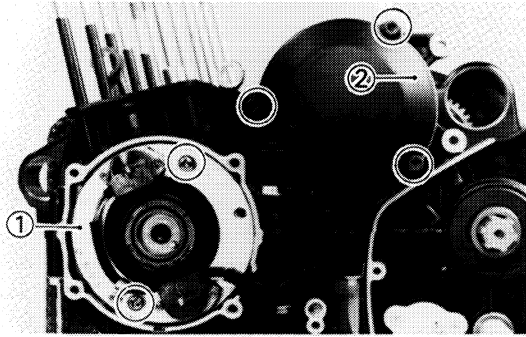

2. Remove:
 - Pickup coil assembly ①
 - Generator cover ②

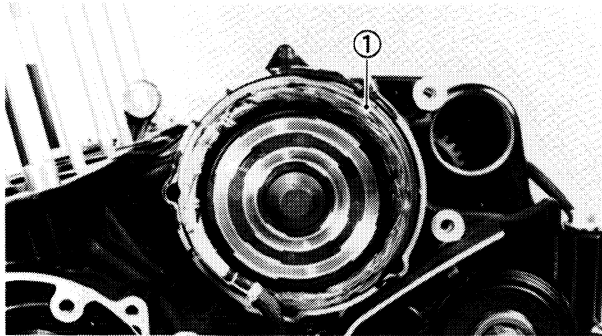

3. Remove:
 - Stator coil ①

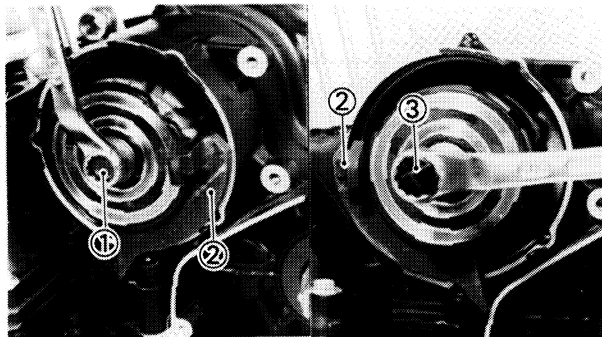

4. Remove:
 - Rotor securing bolt ①
 - Rotor
 Use Rotor Holding Tool ② (YM-04043), Rotor Puller ③ (YM-01080) and Pin (YM-04052).

3

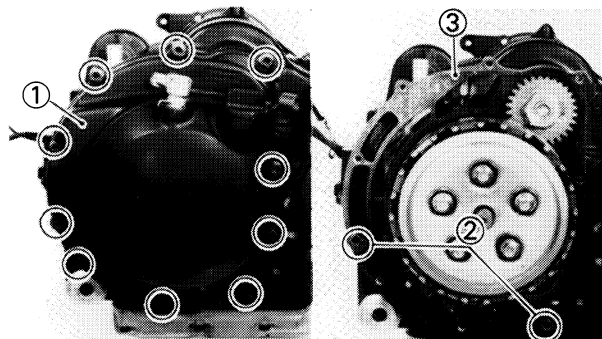

CLUTCH

1. Remove:
 - Right crankcase cover ①
 - Dowel pins ②
 - Gasket ③

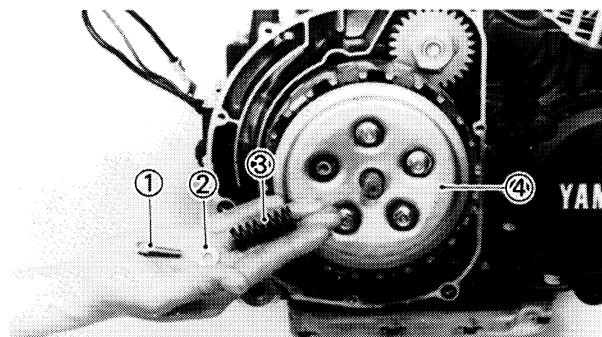

2. Remove:
 - Bolts ①
 - Plate washers ②
 - Springs ③
 - Pressure plate ④
 - Friction plates
 - Clutch plates

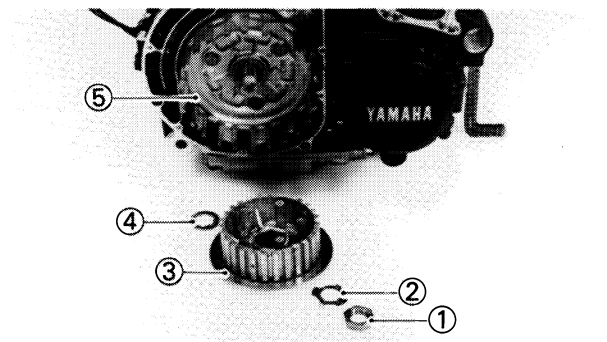
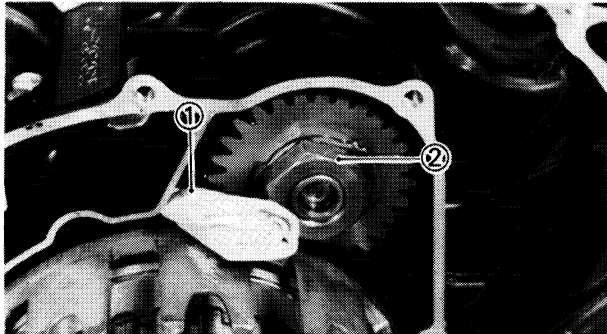
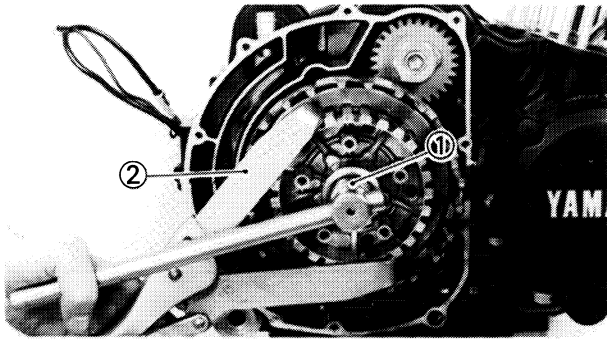

3. Loosen:

- Nut ①
- Use Universal Clutch Holder ② (YM-91042).

NOTE:

If you need to remove the primary drive gear at this stage, place a piece of rolled rag ① or lead between the primary drive gears. Then loosen the drive gear nut ②.

4. Remove:

- Nut ①
- Lock washer ②
- Clutch boss ③
- Thrust washer ④
- Clutch housing ⑤

OIL PUMP AND SHIFT SHAFT

1. Remove:

- Circlip ①
- Oil pump driven gear ②
- Oil pump assembly ③
- O-rings ④

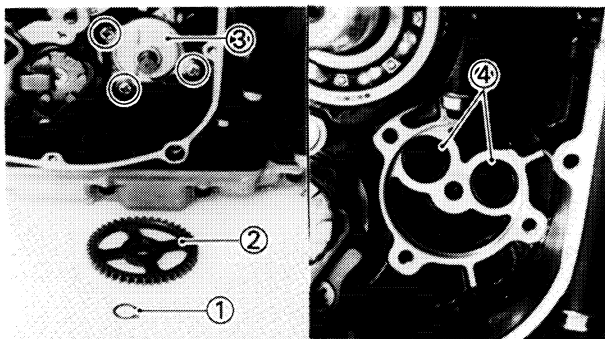

2. Remove:

- Collar ①
- Plate washer ②
(from left side shift shaft.)

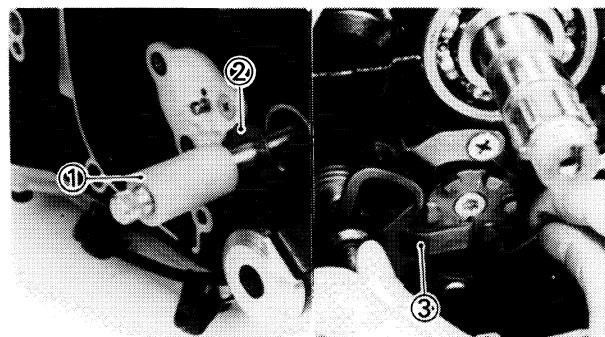

3. Unhook the shift lever 2 ③ and pull the shift shaft.

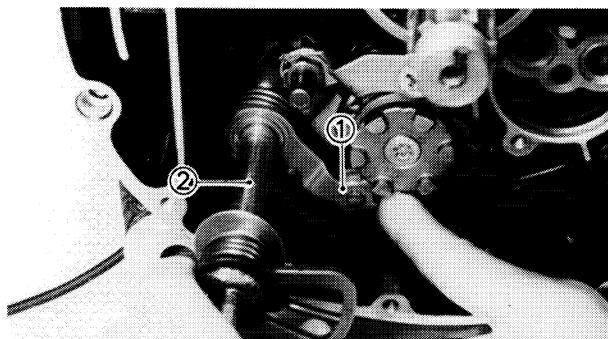

4. Unhook the stopper lever ①

5. Remove:

- Shift shaft assembly ②

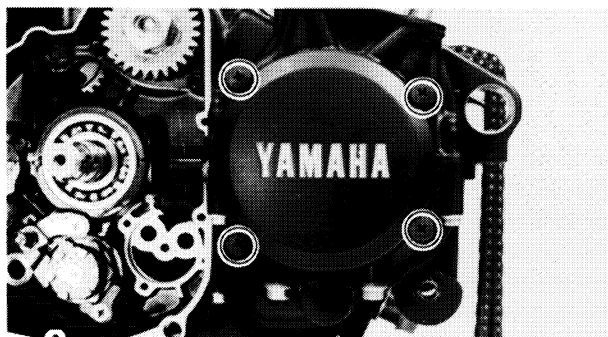

CRANKCASE DISASSEMBLY

1. Remove:

- Right-front crankcase cover

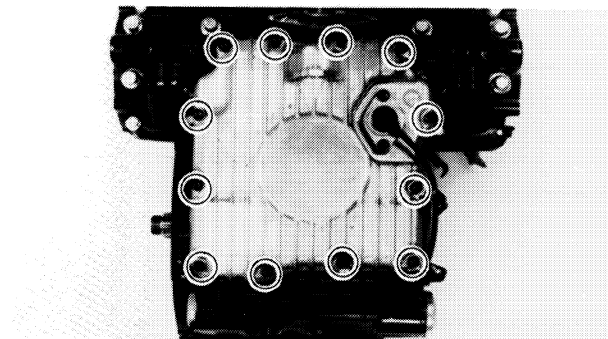

2. Remove:

- Oil pan

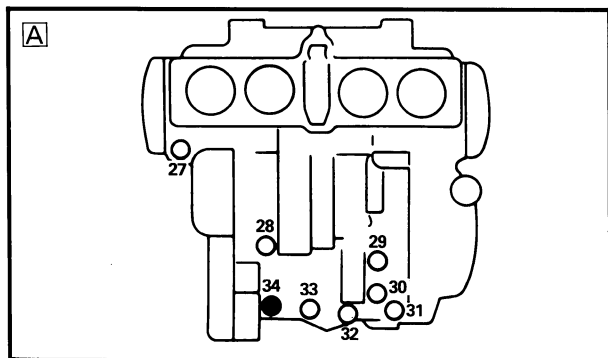

3. Remove:

- Upper crankcase bolts **A**
- Lower crankcase bolts **B**

NOTE:

- Remove the bolts starting with the highest numbered one.
- The embossed numbers in the crankcase designate the crankcase tightening sequence.

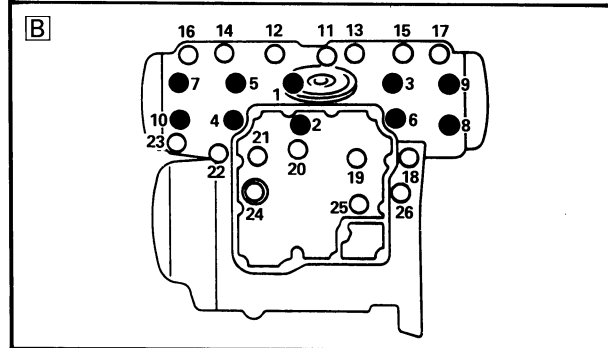

- 8 mm (0.32 in) Bolt
- 6 mm (0.24 in) Bolt



4. Remove:

- Lower crankcase
- Use a rubber hammer.

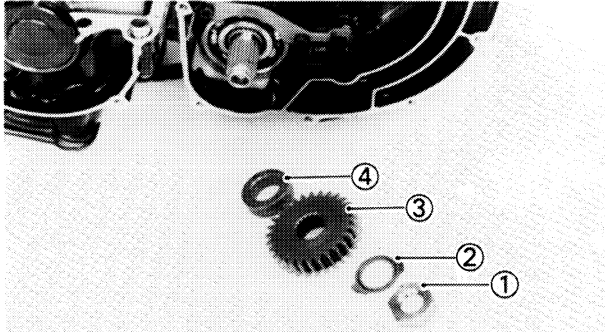

UPPER CRANKCASE

1. Remove:

- Nut ①
- Lock washer ②
- Primary drive gear ③
- Collar ④

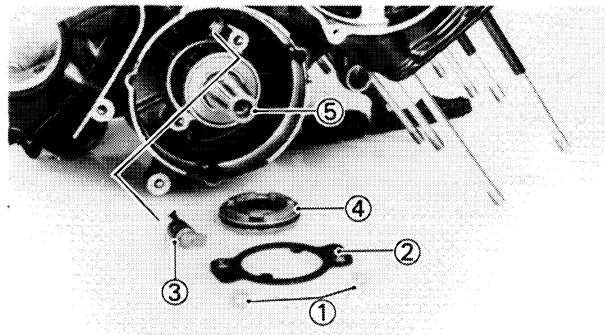

2. Remove:

- Screw ①
- Cover plate ②
- Oil spray nozzle ③
- Bearing housing ④
- A.C.G. shaft ⑤

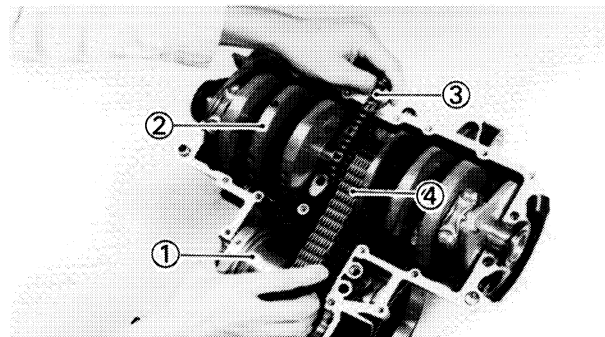

3. Remove:

- Starter clutch damper assembly ①
- Crankshaft assembly ②
- Cam chain ③
- HY-VO chain ④

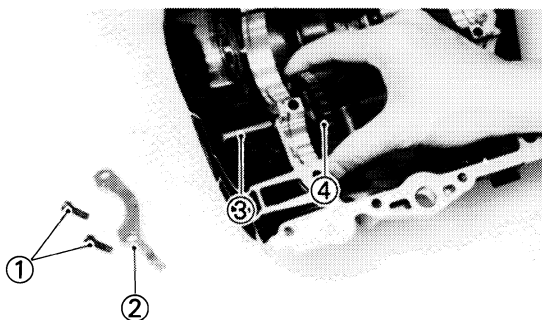

4. Remove:

- Screws ①
- Bearing stopper ②
- Shaft ③
- Starter idler gear ④



LOWER CRANKCASE

1. Remove:

- Drive axle assembly ①
- Main axle assembly ②

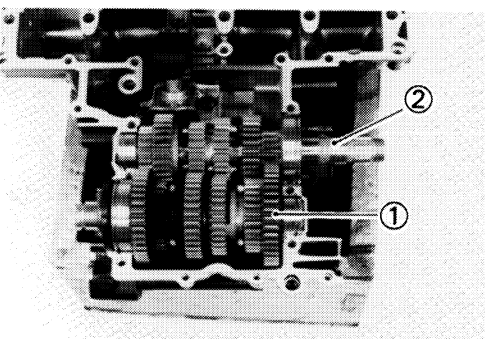

2. Remove:

- Lock washer ①
- Stopper screw ②
- Screws ③
- Guide bar stopper ④
- Bearing stopper ⑤

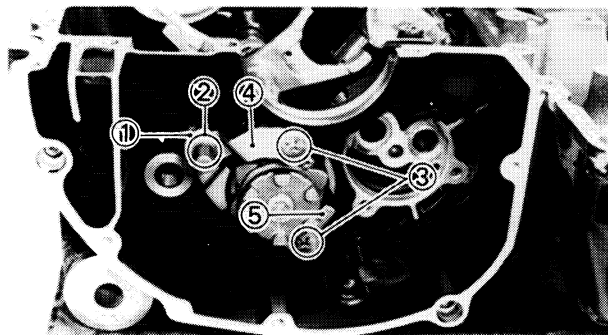

3. Remove:

- Guide bar ①
- Shift forks ②
- Shift cam assembly ③

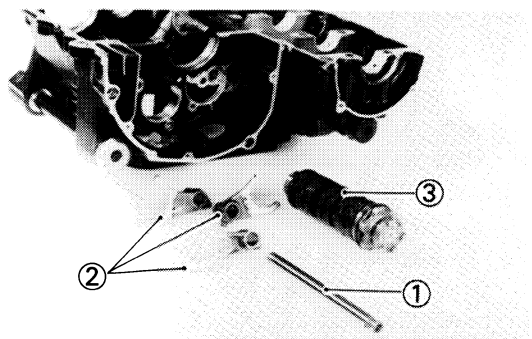

4. Remove:

- HY-VO chain guide ①
- HY-VO chain tensioner ②
- Tensioner plunger ③
- Spring

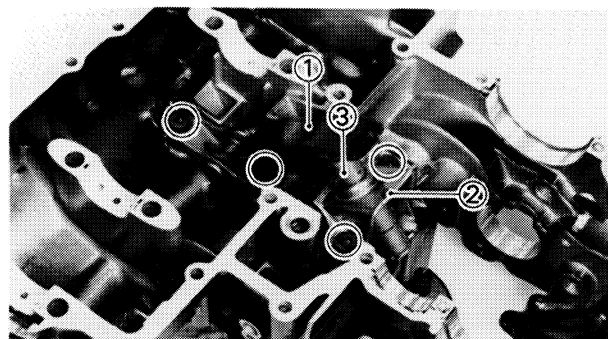

5. Remove:

- Oil strainer ①
- Screw ②
- Strainer housing ③
- Relief valve ④
- Tensioner side relief valve ⑤

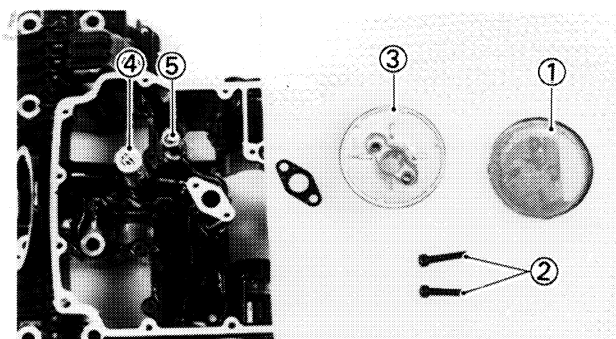

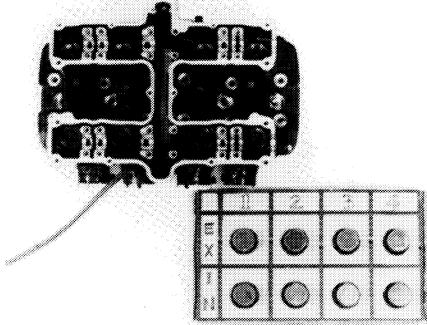

**INSPECTION AND REPAIR
CYLINDER HEAD**

1. Remove:

- Valve pads
- Lifters
- Spark plugs

NOTE: _____

Identify each lifter and pad position very carefully so that it can be reinstalled in its original place.

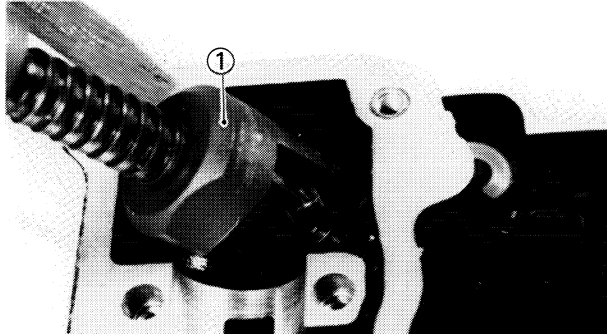

2. Attach:

- Valve Spring Compressor (YM-04019) ①

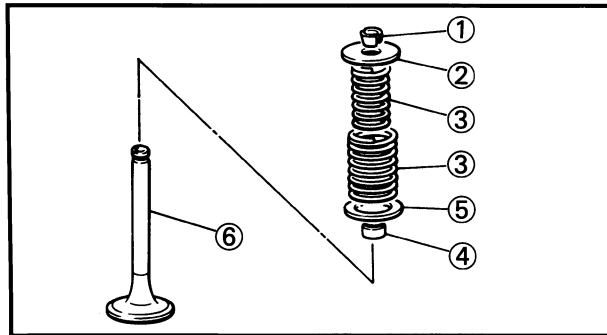

3. Remove:

- Valve retainers ①
- Valve spring seat ②
- Valve springs ③
- Oil seal ④
- Valve spring seat ⑤
- Valve ⑥

NOTE: _____

Deburr any deformed valve stem end. Use an oil stone to smooth the stem end.

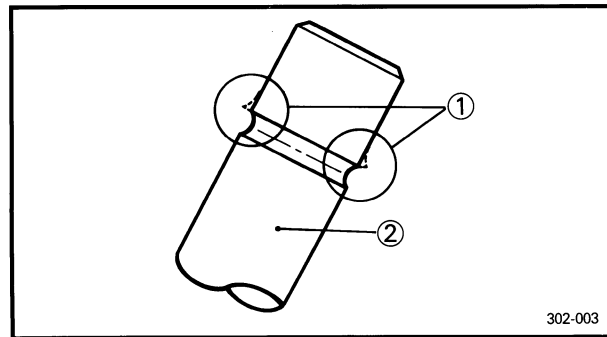

- ① Deburr
- ② Valve stem

4. Eliminate:

- Carbon deposit
(from combustion chamber)
Use rounded scraper.

NOTE: _____

Do not use a sharp instrument and avoid damaging or scratching:

- Spark plug threads
- Valve seat
- Aluminum

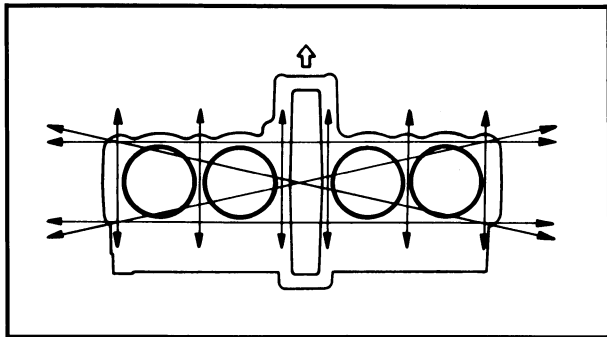

5. Measure:

- Warpage

Exceeds allowable limit → Resurface.



Cylinder Head Warpage:
 Less than 0.03 mm (0.0012 in)
Allowable Limit:
 0.25 mm (0.010 in)

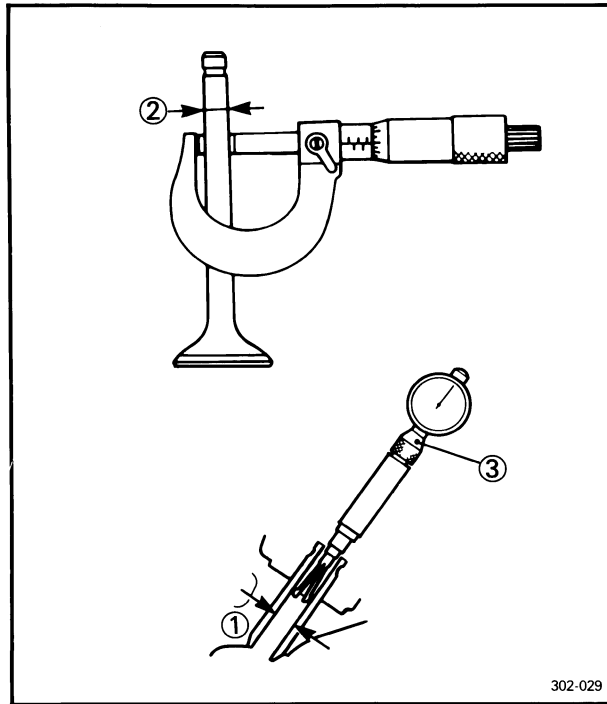

VALVE, VALVE GUIDE, VALVE SEATS AND VALVE SPRING

1. Measure:

- Valve stem clearance

Valve Stem Clearance =
Valve Guide Inside Diameter ①
 – **Valve Stem Diameter ②**

Out of specification → Replace valve or guide.



	Valve Stem Clearance	Maximum
Intake	0.010 ~ 0.037 mm (0.0004 ~ 0.0015 in)	0.10 mm (0.004 in)
Exhaust	0.025 ~ 0.052 mm (0.0010 ~ 0.0020 in)	0.12 mm (0.005 in)

③ Bore gauge

2. Measure:

- Valve face

Pitting/Wear → Re grind.

Out of specification → Replace.

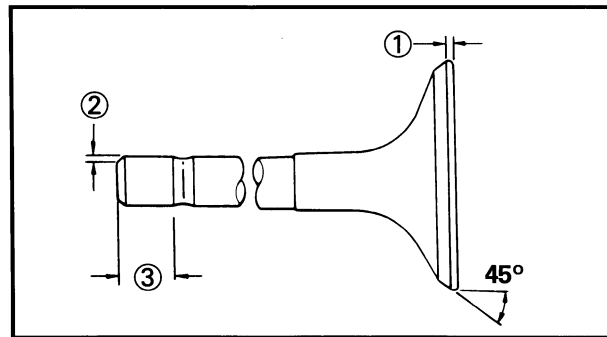

Minimum Thickness (Service Limit) ①:
 0.7 mm (0.0276 in)
Beveled ②: 0.5 mm (0.020 in)
Minimum Length (Service Limit) ③:
 4.0 mm (0.157 in)

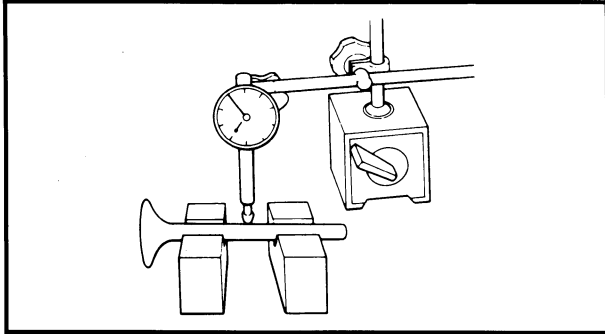

3. Check:

- Valve stem end
Mushroom shape or diameter larger than rest of stem → Replace.
- Runout
Out of specification → Replace.



Valve Stem Runout Limit:
0.03 mm (0.0012 in)

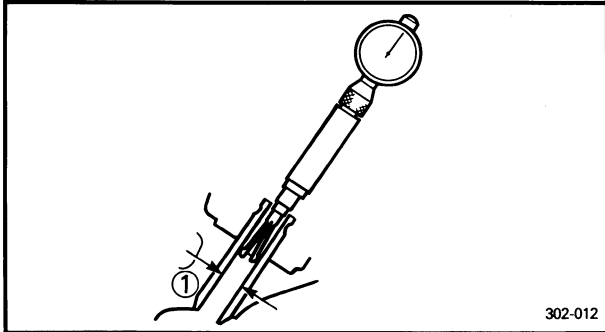

4. Measure:

- Valve guide (inside diameter) ①
Out of specification → Replace.



Guide Inside Diameter Limit:
IN. 6.045 mm (0.238 in)
EX. 6.020 mm (0.237 in)

302-012

5. Inspect:

- Valve guide
Wear/Oil leakage → Replace.

NOTE:

Heat the cylinder head in an oven to 100°C (212°F) to ease valve guide removal and reinstallation and to maintain correct interference fit.

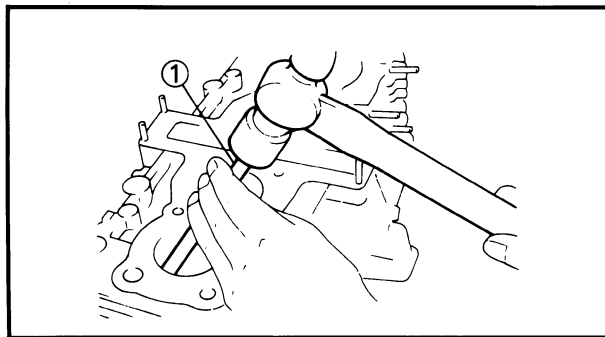

Valve Guide Replacement

1. Remove:

- Valve guide
Use Valve Guide Remover (YM-04064) ①.

NOTE:

- Always replace valve guide if valve is replaced.
- Always replace oil seal if valve is removed.

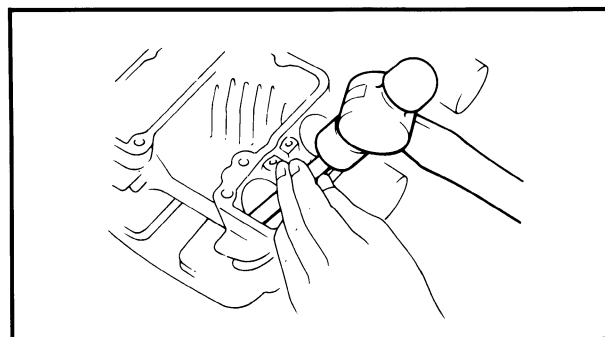

2. Install:

- Valve guide (new)
Use Valve Guide Installer (YM-04065) and Valve Guide Remover (YM-04064).

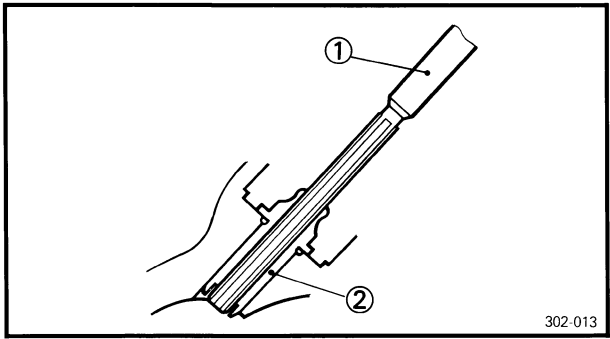

3. Bore valve guide (2) to obtain proper valve stem clearance.
Use 6 mm (0.24 in) Reamer (YM-04066) (1).

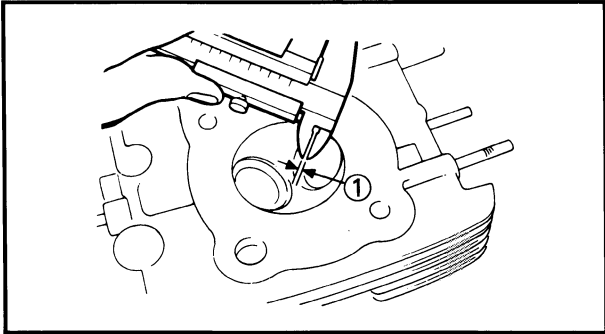

Valve Seat

1. Inspect:
 - Valve seat
Pitting/Wear → Cut.
2. Measure:
 - Valve seat width (1)
Out of specification → Follow next steps.

	Standard width	Wear limit
Valve seat width	$1.0 \pm 0.1 \text{ mm}$ ($0.039 \pm 0.0039 \text{ in}$)	2.0 mm (0.078 in)

3

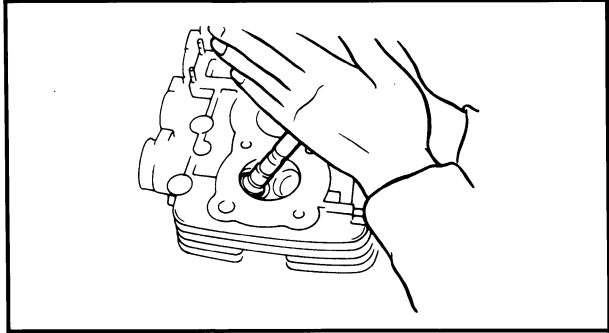

3. Apply:
 - Mechanic's bluing dye (Dykem)
(to valve and seat)
4. Position:
 - Valve
(into cylinder head)
5. Spin it rapidly back and forth, then lift valve and clean off all grinding compound.
6. Inspect:
 - Valve seat surface
Wherever valve seat and valve face made contact, bluing will have been removed.
7. Measure:
 - Valve seat width
Valve seat width must be uniform in contact area.
Out of specification → Cut.

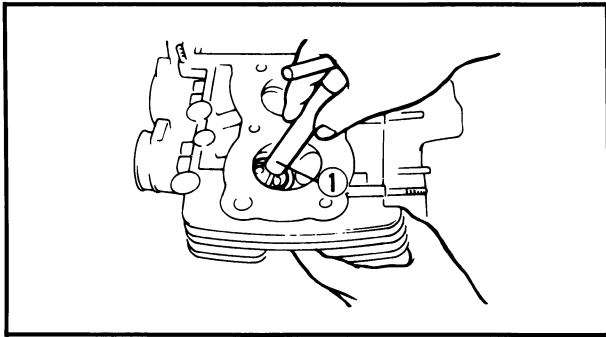

8. Cut valve seat.

NOTE: _____
 Cut valve seat using valve seat cutter ① if valve seat width exceeds limit or if valve seat is pitted or worn.

CAUTION: _____
 When twisting cutter, keep an even downward pressure to prevent cutter marks.

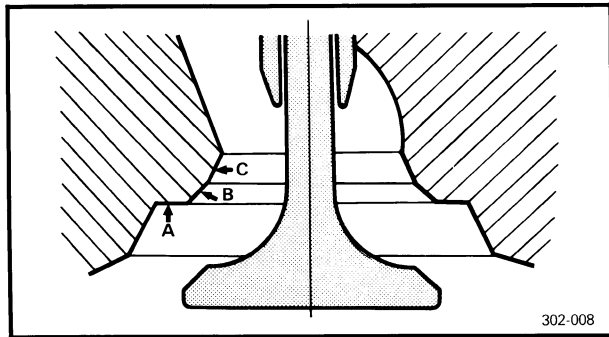

302-008

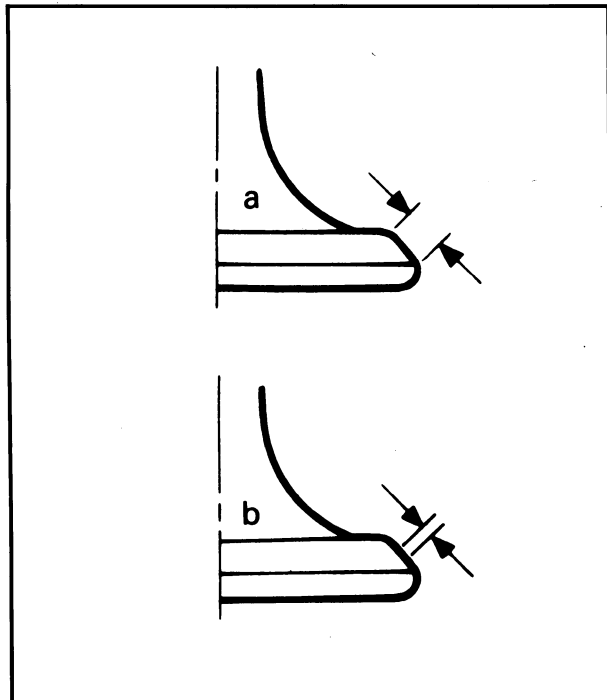

Valve seat recutting steps are necessary if:
 • Valve seat is uniform around perimeter of valve face but too wide or too narrow or not centered on valve face.

Cut Valve Seat As Follows:	
Section A	0° Cutter
Section B	45° Cutter
Section C	60° Cutter

• Valve face indicates that valve seat is centered on valve face but is wide (See "a" diagram).

Valve Seat Cutter Set		Desired Result
Use	0° Cutter	to reduce valve seat width.
	60° Cutter	

• Valve seat is in the middle of the valve face but too narrow (See "b" diagram).

Valve Seat Cutter Set		Desired Result
Use	45° Cutter	to achieve a uniform valve seat width (Standard specification).

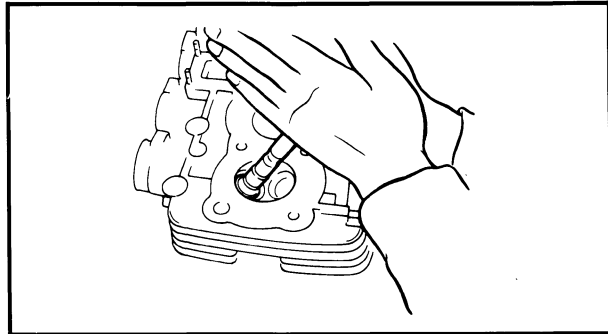
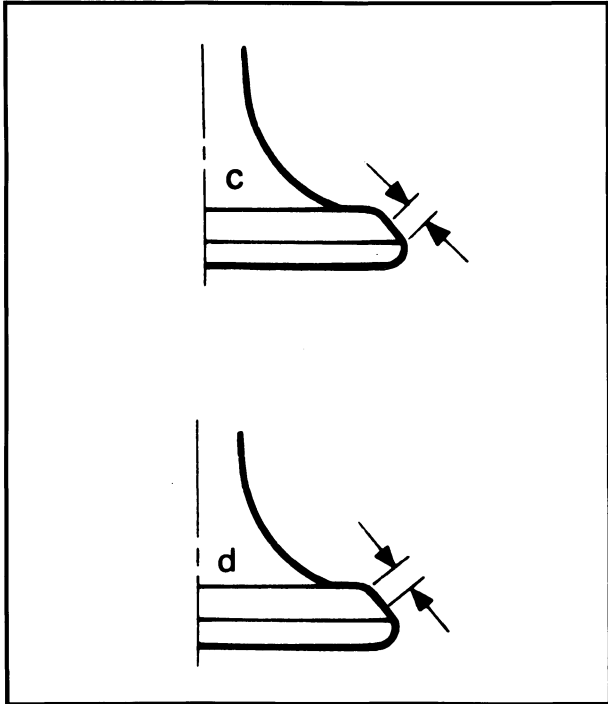

• Valve seat is too narrow and right up near valve margin (See "c" diagram).

Valve Seat Cutter Set		Desired Result
Use	0° Cutter, first	to obtain correct seat width.
	45° Cutter	

• Valve seat is too narrow and is located down near the bottom edge of the valve face (See "d" diagram).

Valve Seat Cutter Set		Desired Result
Use	60° Cutter, first	to obtain correct seat width.
	45° Cutter	

NOTE: _____

- Lap valve/valve seat assembly if:
- Valve face/valve seat are used or severely worn.
 - Valve and valve guide has been replaced.
 - Valve seat has been cut.

Valve/Valve Seat Assembly Lapping

1. Apply:
 - Coarse lapping compound (Small amount) (to valve face)
2. Position:
 - Valve (in cylinder head)
3. Rotate:
 - Valve

Turn until valve and valve seat are evenly polished, then clean off compound.



4. Repeat above steps with fine compound and continue lapping until valve face shows a completely smooth surface uniformly.

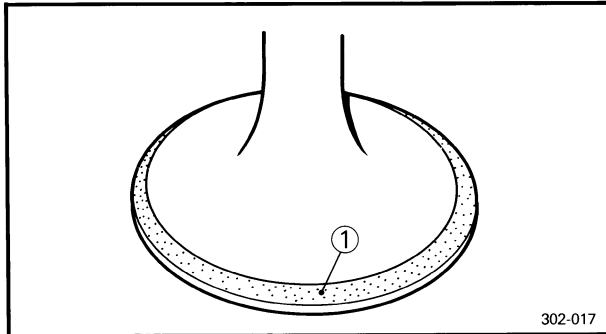

5. Eliminate:
- Compound
(from valve face)
6. Apply:
- Mechanic's bluing dye (Dykem) ①
(to valve face and seat)
7. Rotate:
- Valve
Valve must make full seat contact indicated by grey surface all around valve face where bluing was removed.
8. Apply:
- Solvent
(into each intake and exhaust port)
Leakage past valve seat → Replace valve until seal is complete.

NOTE: _____
Pour solvent into intake and exhaust ports only after completion of all valve work and assembly of head parts.

Relapping steps:

- Disassemble head parts.
- Repeat lapping steps using fine lapping compound.
- Clean all parts thoroughly.
- Reassemble and check for leakage again using solvent.
- Repeat steps as often as necessary to effect a satisfactory seal.

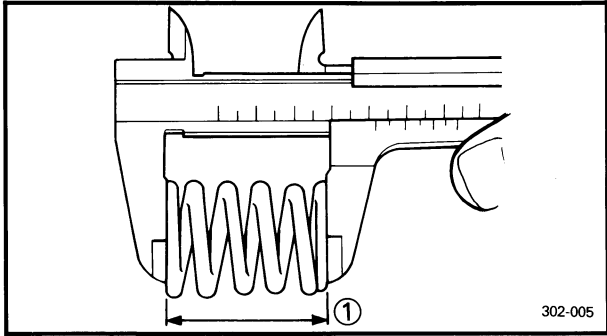

Valve Spring Measurement

1. Measure:

- Valve spring free length ①
Out of specification → Replace.

Valve Spring Free Length			
Inner spring		Outer spring	
Standard	Wear limit	Standard	Wear limit
35.5 mm (1.398 in)	33.5 mm (1.319 in)	37.2 mm (1.465 in)	35.2 mm (1.386 in)

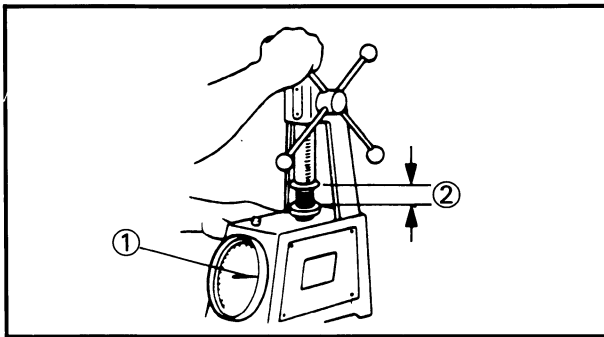

2. Measure:

- Valve spring installed force ①
Out of specification → Replace.

Valve Spring Installed Force			
Inner spring		Outer spring	
②	①	②	①
30.5 mm (1.20 in)	9.3 kg (20.5 lb)	32.0 mm (1.26 in)	18.5 kg (40.8 lb)

② Installed length

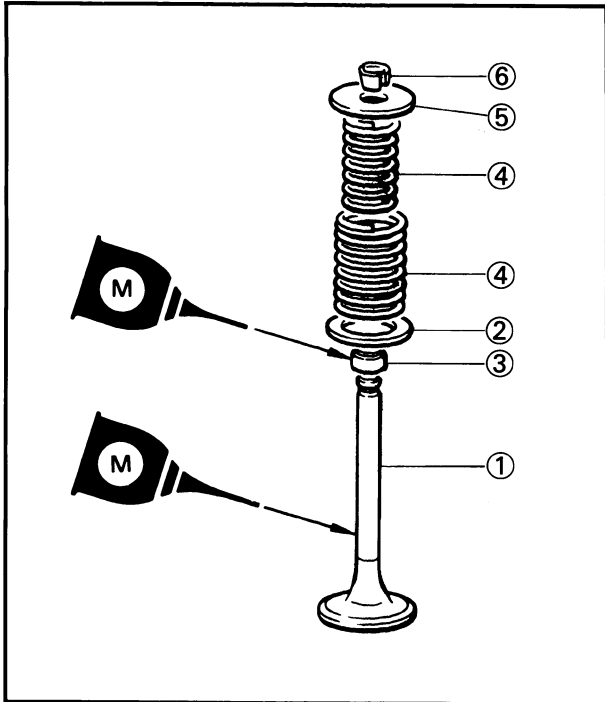

Valve Installation

1. Lubricate:

- Valve stem
- Oil seal



High-Quality Molybdenum Disulfide Motor Oil or Molybdenum Disulfide Grease

2. Install:

- Valve ①
- Valve spring seat ②
- Oil seal ③
- Valve springs ④
- Valve spring seat ⑤
- Valve retainers ⑥

NOTE:

Install all springs with wider-gapped coils facing upwards as shown.

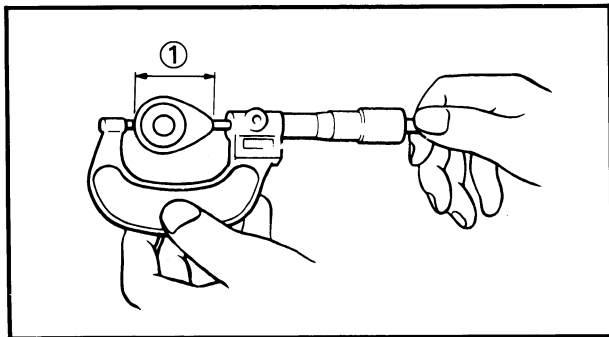

CAMSHAFT, CAM CHAIN AND CAM SPROCKET

Camshaft

1. Measure:

- Large cam lobe length ①
- Small cam lobe length ②

Use a micrometer.

Out of specification → Replace.

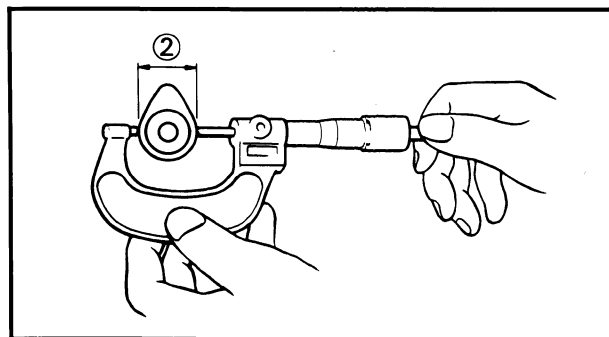

	Intake	Exhaust
①	36.25 ~ 36.35 mm (1.427 ~ 1.431 in)	35.75 ~ 35.85 mm (1.408 ~ 1.411 in)
②	28.10 ~ 28.20 mm (1.106 ~ 1.110 in)	28.05 ~ 28.15 mm (1.104 ~ 1.108 in)



Camshaft/Cap Clearance Measurement

1. Install:
 - Camshaft
2. Position:
 - Strip of Plastigage® (YU-33210)
(onto camshaft.)
3. Install:
 - Dowel pins
 - Camshaft caps



10 Nm (1.0 m•kg, 7.2 ft•lb)

NOTE:

Do not turn the camshaft when measuring clearance with Plastigage®.

4. Remove:
 - Camshaft caps
5. Measure:
 - Width of Plastigage® ①
Out of specification → Follow step 6.



Camshaft-to cap Clearance:
Standard: 0.020 ~ 0.054 mm
 (0.0008 ~ 0.0021 in)
Maximum: 0.160 mm (0.006 in)

6. Measure:
 - Camshaft bearing surface diameter
Use micrometer.
Out of specification → Replace camshaft.
Within specification → Replace cylinder head.



Bearing Surface Diameter:
Standard: 24.967 ~ 24.980 mm
 (0.9830 ~ 0.9835 in)

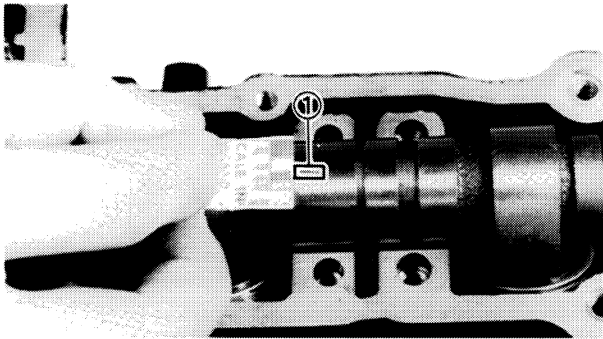

3

Cam Chain

1. Inspect:
 - Cam chain
Chain stretch/Cracks → Replace.

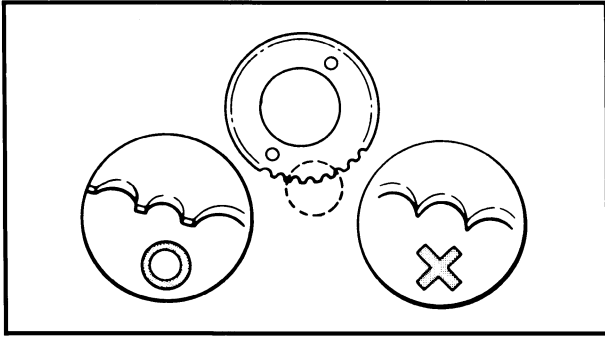

Cam Sprockets

1. Inspect:
 - Cam sprockets
 - Wear/Damage → Replace.

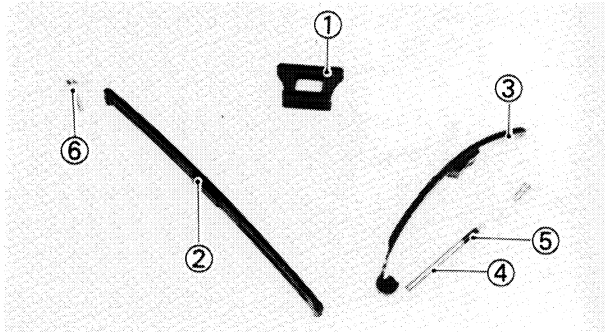

Cam Chain Dampers

1. Inspect:
 - Upper damper ①
 - Exhaust side chain guide ②
 - Intake side chain guide ③
 - Chain guide stopper ④
 - Spring ⑤
 - Guide stopper plate ⑥
- Wear/Damage → Replace.

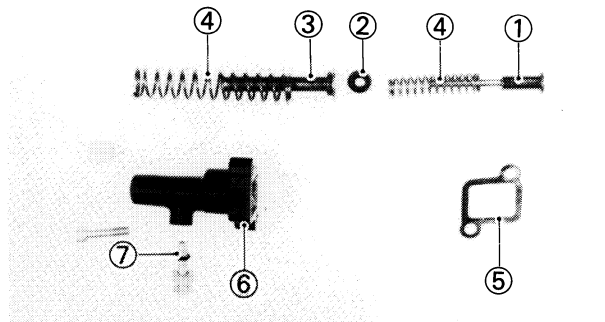

Cam Chain Tensioner

1. Inspect:
 - All parts
 - Damage/Wear → Replace.

- ① Tensioner rod (Small)
- ② Damper
- ③ Tensioner rod (Large)
- ④ Spring
- ⑤ Gasket
- ⑥ Tensioner body
- ⑦ O-ring

CYLINDER

1. Inspect:
 - Cylinder walls
 - Vertical scratches → Rebore or Replace cylinder.

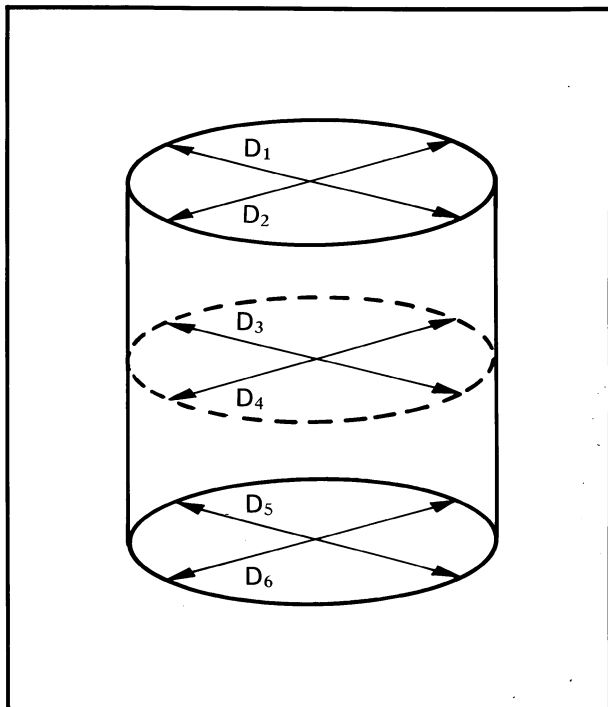

2. Measure:
- Cylinder inside diameter

NOTE: _____

Obtain measurements at three depths by placing measuring instrument parallel to and at right angles to crankshaft.

Out of specification → Rebore cylinder, and replace piston and piston rings.

/	Standard	Wear limit
Cylinder bore: C	58.5 mm (2.303 in)	58.6 mm (2.307 in)
Cylinder taper: T	—	0.05 mm (0.002 in)

C = Maximum D
T = Maximum D₁, D₂ – Minimum D₅, D₆

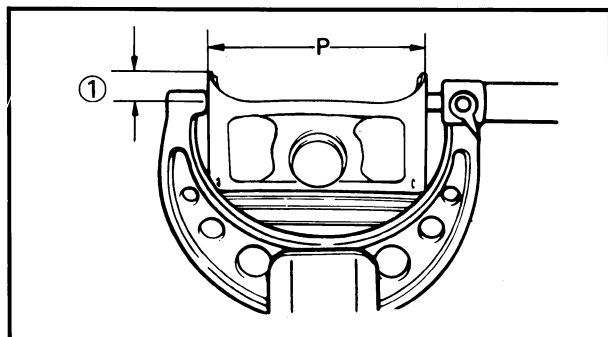

PISTON, PISTON RING AND PISTON PIN

3

Piston

1. Measure:
- Piston skirt diameter "P"

NOTE: _____

Measure the piston skirt diameter where the distance 7.0 mm (0.276 in) ① from the piston bottom edge.

	Piston size
Standard	58.50 mm (2.303 in)
Over size 2	59.00 mm (2.323 in)
Over size 4	60.00 mm (2.362 in)

2. Measure:
- Piston clearance

Out of specification → Rebore cylinder or replace piston.

Piston Clearance = C – P:
 0.025 ~ 0.045 mm
 (0.0010 ~ 0.0019 in)

C: Cylinder bore P: Piston outside diameter

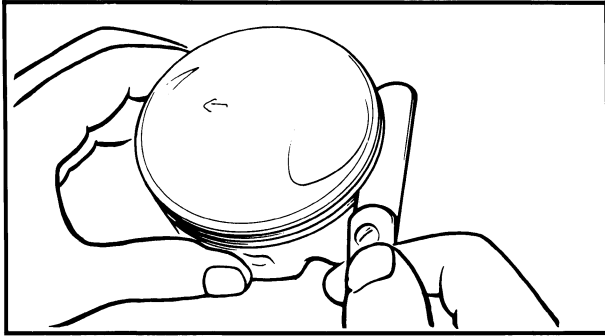

Piston Ring

1. Measure:

- Ring side clearance

Use a feeler gauge.

Out of specification → Replace piston.

NOTE:

Clean carbon from piston ring grooves and rings before measuring side clearance.

Piston Ring Side Clearance:	
Top	0.03 ~ 0.07 mm (0.0012 ~ 0.0028 in)
2nd	0.02 ~ 0.06 mm (0.0008 ~ 0.0024 in)

2. Position:

- Piston ring
(in cylinder)

NOTE:

Insert a ring into cylinder, and push it approximately 20 mm (0.8 in) into cylinder. Push ring with piston crown so that ring will be at a right angle to cylinder bore.

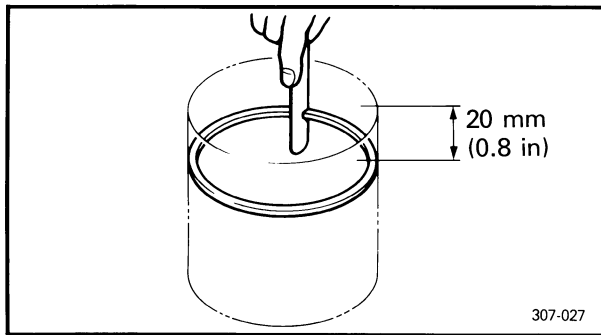

3. Measure:

- Ring end gap

Out of specification → Replace.

NOTE:

You cannot measure end gap on expander spacer of oil control ring. If oil control ring rails show excessive gap, replace all three rings.

	Standard	Limit
Top ring	0.15 ~ 0.30 mm (0.0059 ~ 0.0118 in)	0.70 mm (0.0276 in)
2nd ring	0.15 ~ 0.30 mm (0.0059 ~ 0.0118 in)	0.70 mm (0.0276 in)
Oil control (Rails)	0.2 ~ 0.7 mm (0.008 ~ 0.028 in)	—

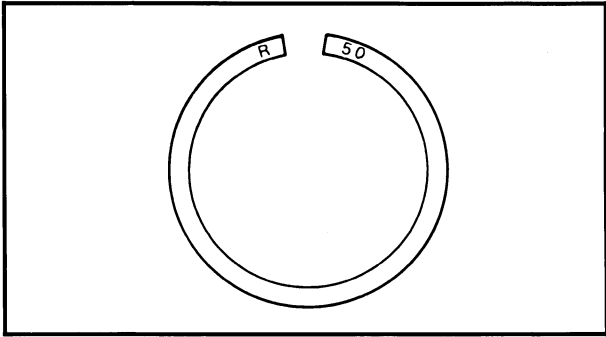

Piston Ring Oversize

- Top and 2nd piston ring
Oversize top and middle ring sizes are stamped on top of ring.

Oversize 2	50
Oversize 4	100

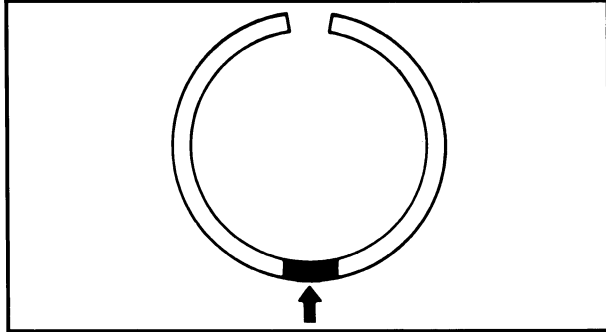

- Oil control ring
Expander spacer of bottom ring (oil control ring) is color-coded to identify sizes.

Size	Color
Oversize 2	Blue
Oversize 4	Yellow

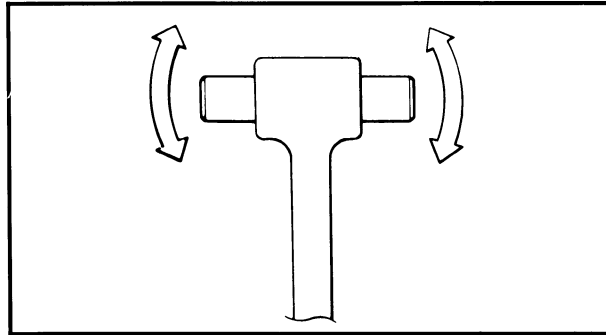

Piston Pin

1. Lubricate:
 - Piston pin (Lightly)
2. Install:
 - Piston pin
(into small end of connecting rod)
3. Check:
 - Free play
Free play → Inspect connecting rod for wear.
Wear → Replace connecting rod and piston pin.
4. Position:
 - Piston pin
(into piston)
5. Check:
 - Free play
(into piston)
Free play → Replace piston pin and/or piston.

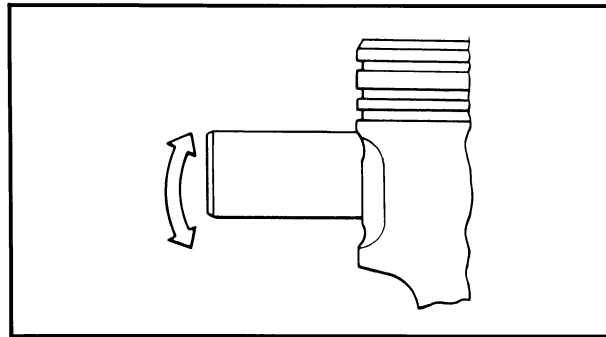

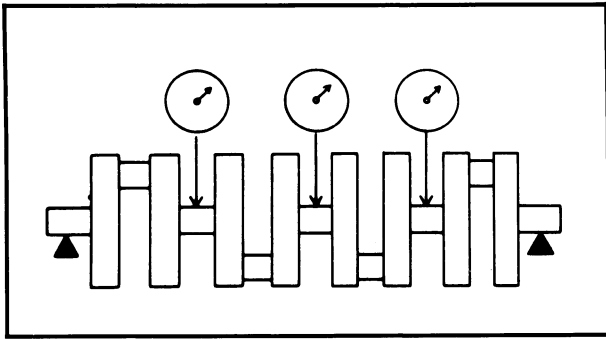

CRANKSHAFT AND CONNECTING ROD Crankshaft Runout

1. Place both ends of crankshaft on V-blocks.
2. Rotate:
 - Crankshaft
3. Measure:
 - Crankshaft runout
(at main journal bearings)
Use a Dial Gauge.



Crankshaft Runout Limit:
0.03 mm (0.0012 in)

Connecting Rod Bearings

1. Inspect:
 - Bearings
Burns/Flaking/Roughness/Scratches →
Replace.

Connecting Rod Bearing Clearance

1. Clean all parts thoroughly.
2. Install:
 - Connecting rod bearings
(into connecting rod and cap)
3. Attach:
 - Plastigage®
(onto crankpin)
4. Position:
 - Connecting rod
(onto crankshaft)
 - Connecting rod cap
5. Apply:
 - Molybdenum disulfide grease
(to bolt threads)
Torque both ends of rod cap evenly.

NOTE: _____
Do not move connecting rod until a clearance measurement has been completed.

**CAUTION:**

Tighten to full torque specification without pausing. Apply continuous torque between 2.0 and 2.5 m•kg. Once you reach 2.0 m•kg DO NOT STOP TIGHTENING until final torque is reached. If tightening is interrupted between 2.0 and 2.5 m•kg, loosen nut to less than 2.0 m•kg and start again.



25 Nm (2.5 m•kg, 18 ft•lb)

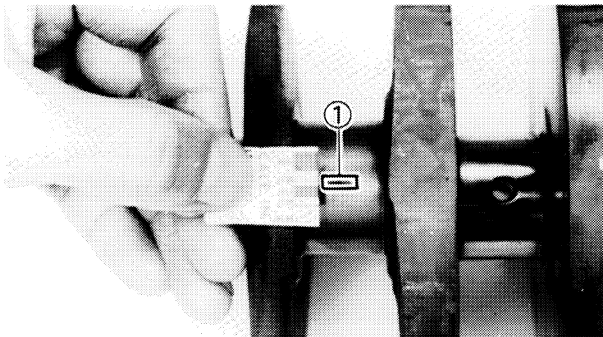

6. Remove:

- Connecting rod cap
Remove carefully.

7. Measure:

- Plastigage® width ①
Out of specification → Replace connecting rod bearing.



Connecting Rod Bearing Clearance:

0.016 ~ 0.040 mm
(0.0006 ~ 0.0016 in)

Crankshaft Main Bearing Clearance Measurement

1. Clean all parts.
2. Position:
 - Upper crankcase half
Place on a bench in an upside down position.
3. Install:
 - Bearings
(into the upper crankcase)
4. Attach:
 - Plastigage® (YU-33210)
(onto the crankshaft journal surface)

NOTE:

Do not move crankshaft until clearance measurement has been completed)



5. Install:
- Bearings
(into lower crankcase)
 - Lower crankcase

6. Tighten:
- Bolts

CAUTION:

Tighten to full torque in torque sequence cast on the crankcase.



8 mm (0.3 in) Bolt:
24 Nm (2.4 m•kg, 17 ft•lb)

7. Remove:
- Bolts
Reverse assembly order
 - Lower crankcase
Use care in removing.

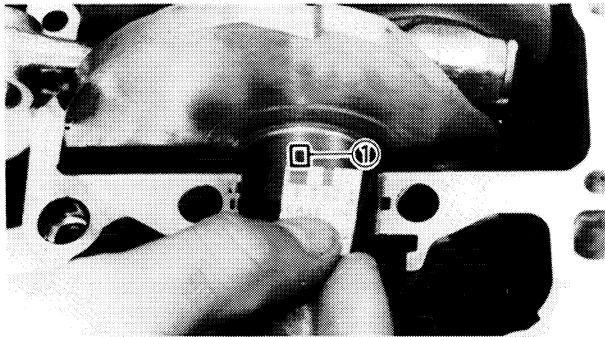

8. Measure:
- Plastigage® width ① (YU-33210)
Out of specification → Replace bearings;
replace crankshaft if necessary.



Main Bearing Oil Clearance:
0.021 ~ 0.044 mm
(0.0008 ~ 0.0017 in)

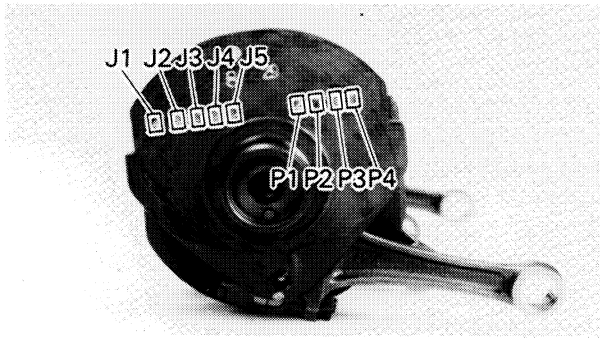

Crankshaft Main and Connecting Rod Bearing Selection

- Numbers used to indicate crankshaft journal sizes are stamped on the LH crankweb. The first five (5) are main bearing journal numbers, starting with the left journal. The four (4) rod bearing journal numbers follow in the same sequence.

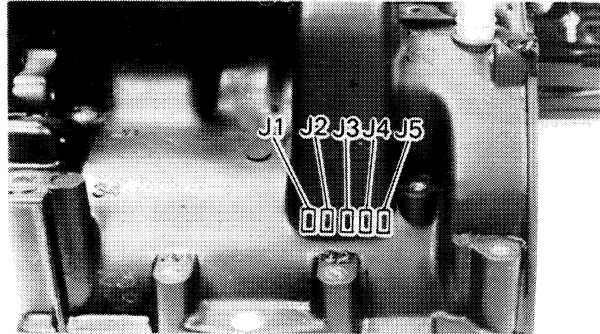

- The upper crankcase half is numbered J1, J2, J3, J4, and J5 on the rear right boss as shown.

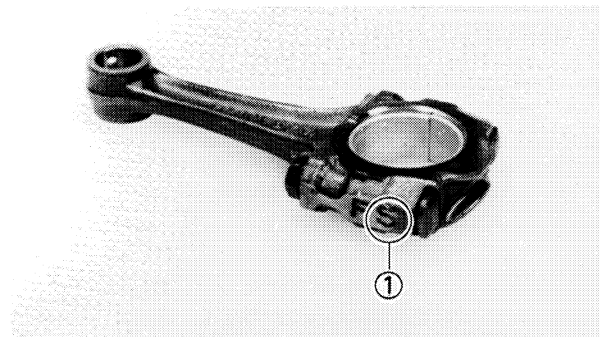
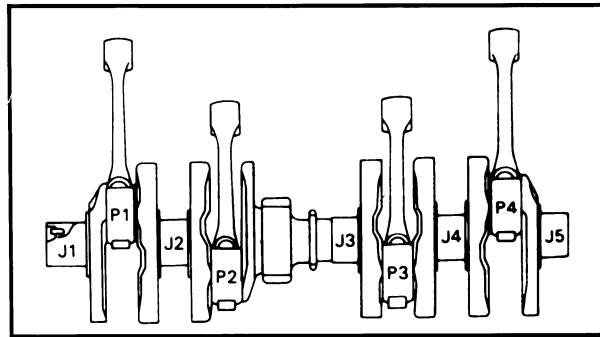

- The connecting rods are numbered 4 or 5. The numbers are stamped in ink on the rod cap ①.

Bearing color code	
No. 1	Blue
No. 2	Black
No. 3	Brown
No. 4	Green
* No. 5	Yellow

* No. 5 applies only to the crankshaft main bearing selection.



Example 1: Selection of the crankshaft main bearing; If the crankcase J1 and crankshaft J1 sizes are No. 4 and No. 1, respectively, the bearing size No. is:

$$\begin{aligned} \text{Bearing size No.} &= \\ \text{Crankcase No.} - \text{Crankshaft No.} &= \\ 4 - 1 &= 3 \text{ (Brown)} \end{aligned}$$

Example 2: Selection of the connecting rod bearing; If the connecting rod P1 and crankshaft P1 sizes are No. 4 and No. 1, respectively, the bearing size No. is:

$$\begin{aligned} \text{Bearing size No.} &= \\ \text{Connecting rod No.} - \text{crankshaft No.} &= \\ 4 - 1 &= 3 \text{ (Brown)} \end{aligned}$$

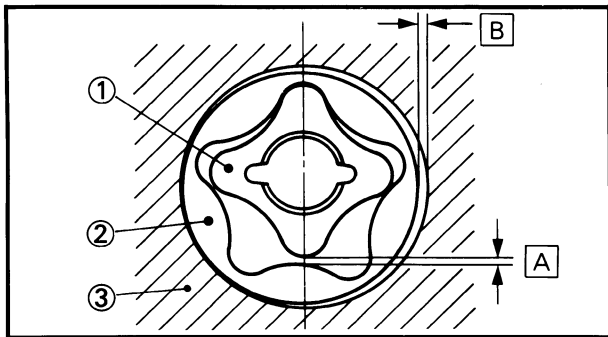
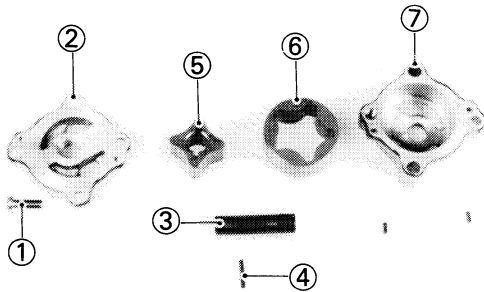

OIL PUMP

1. Remove:

- Screw ①
- Pump cover ②
- Shaft ③
- Pin ④
- Inner rotor ⑤
- Outer rotor ⑥
- Pump housing ⑦

2. Measure:

- Clearance "A"
(between inner rotor ① and outer rotor ②)
- Clearance "B"
(between outer rotor ② and pump housing ③)

Oil Pump Clearance:	
Clearance "A"	0.09 ~ 0.15 mm (0.0035 ~ 0.0059 in)
Clearance "B"	0.03 ~ 0.08 mm (0.0012 ~ 0.0031 in)

3. Install:
 - Oil pump parts
4. Tighten:
 - Screw

 **7 Nm (0.7 m•kg, 5.1 ft•lb)**

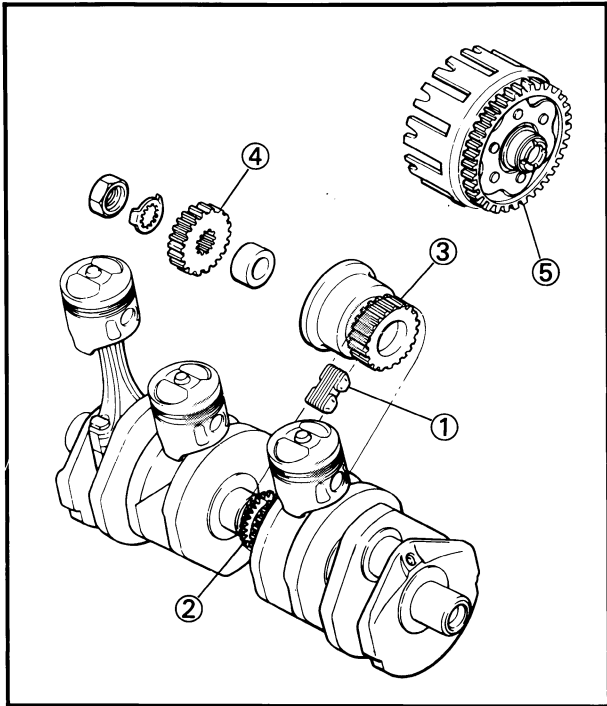

PRIMARY DRIVE

1. Inspect:
 - HY-VO chain ①
 - Crankshaft drive sprocket ②
 - Clutch damper driven sprocket ③
 - Primary drive gear ④
 - Primary driven gear ⑤

Wear/Damage → Replace both gears.
Excessive noises during operation → Replace both gears.

3

Primary reduction ratio		
No. of teeth		Ratio
③/②	⑤/④	
22/21	65/28	2.431



STARTER DRIVES

Electric Starter Clutch

1. Check:
 - Ball operation
 - Spring operation
 - Spring cap operation

Unsmooth operation → Replace one-way clutch.
2. Inspect:
 - Surface of the idle gear

Pitting/Wear/Damage → Replace.

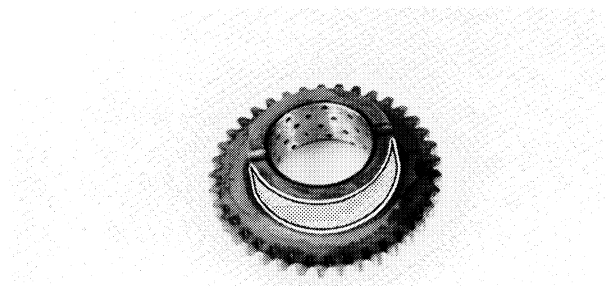

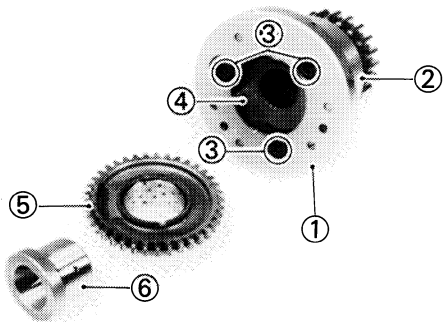

3. Installation:

- a. Install:
 - Cover ①
 - Outer starter clutch ②
- b. Tighten:
 - Bolts ③

	24 Nm (2.4 m•kg, 17 ft•lb)
	LOCTITE® Stake Over the End of the Bolt

- c. Install:
 - Spring
 - Spring cap
 - Ball ④
 - Idle gear ⑤
 - Collar ⑥

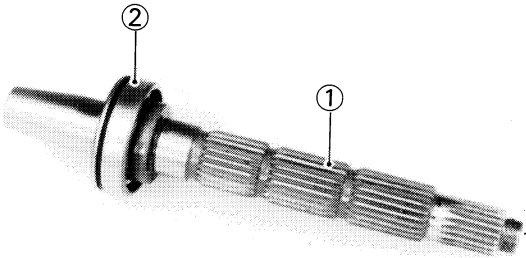

Starter Clutch Shaft

- 1. Check:
 - Shaft ①
Wear/Damage → Replace.
 - Bearing ②
Unsmooth operation → Replace.

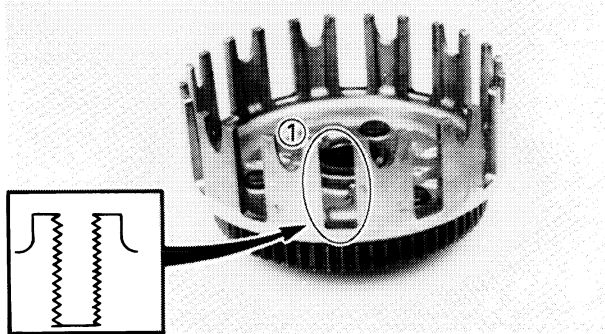

CLUTCH

- 1. Inspect:
 - Clutch housing dogs ①
Cracks/Pitting (edges):
Moderate → Deburr.
Severe → Replace clutch housing.

NOTE: _____
Pitting on friction plate dogs of clutch housing will cause erratic operation.

- 2. Inspect:
 - Clutch housing bearing
Damage → Replace.

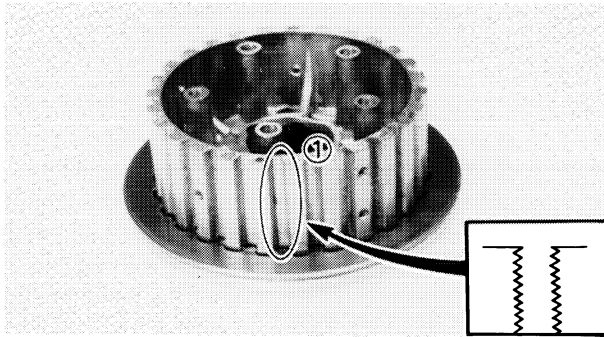

3. Inspect:
- Clutch boss spline ①
- Pitting:
- Moderate → Deburr.
 - Severe → Replace.

NOTE: _____

Pitting on clutch plate splines of clutch boss will cause erratic operation.

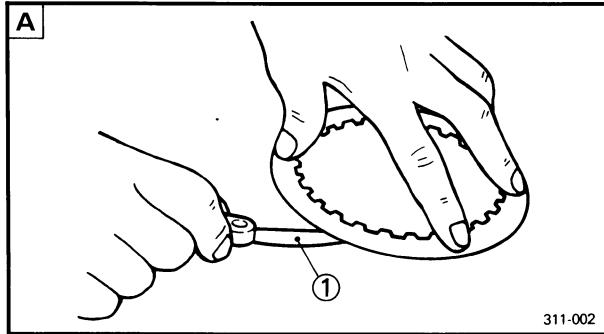

4. Measure:
- Clutch plate warpage **A**
 - Friction plate thickness **B**
- Out of specification → Replace.
Clutch or friction plate as a set.

	Standard	Wear limit
Friction plate thickness	2.9 ~ 3.1 mm (0.114 ~ 0.122 in)	2.7 mm (0.106 in)
Clutch plate warp limit	—	0.15 mm (0.006 in)

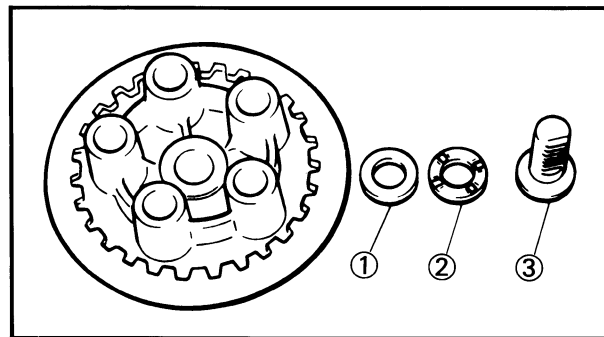
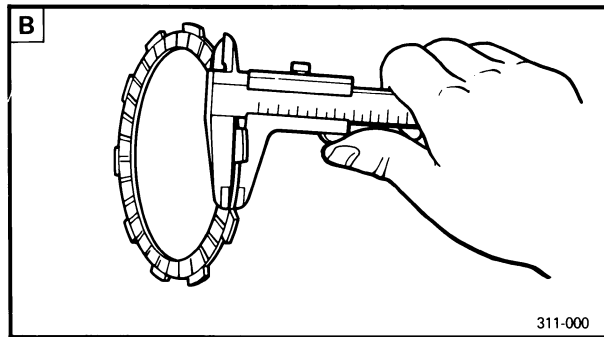

5. Inspect:
- Washer ①
 - Thrust bearing ②
 - Pull rod ③
- Damage → Replace.

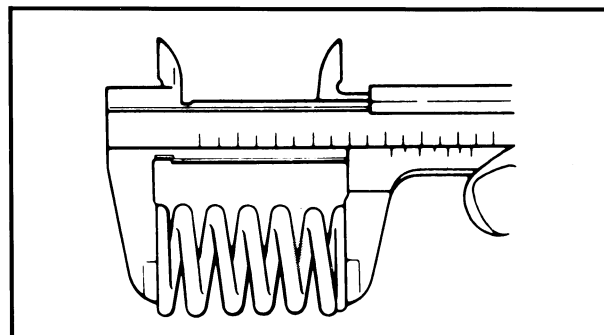

6. Measure:
- Clutch spring free play
- Out of specification → Replace spring as a set.

Clutch Spring Minimum Free Length:
41.8 m (1.64 in)

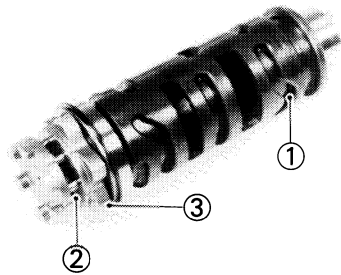
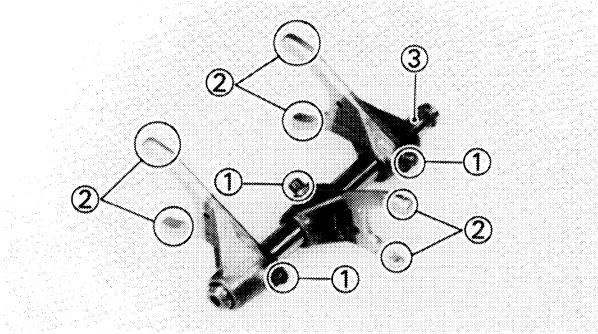

TRANSMISSION

1. Inspect:

- Shift fork cam follower ①
- Shift fork pawl ②
- Scoring/Bends/Wear → Replace.

2. Check:

- Guide bar ③
- Roll across a surface plate.
- Bends → Replace.

3. Inspect:

- Shift cam groove ①
- Shift cam dowel ② and side plate
- Shift cam stopper plate ③ circlip and stopper.
- Wear/Damage → Replace.

4. Measure:

- Transmission shaft runout.
- Use centering device and dial gauge.
- Out of specification → Replace bent shaft.



Runout Limit:
0.08 mm (0.0031 in)

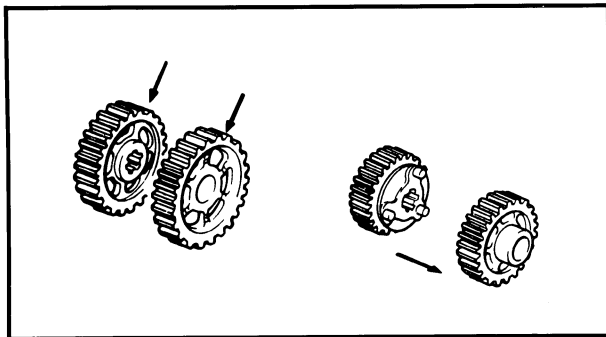

5. Inspect:

- Gear teeth
- Blue discoloration/Pitting/Wear → Replace.
- Mated dogs
- Rounded edges/Cracks/Missing portions → Replace.

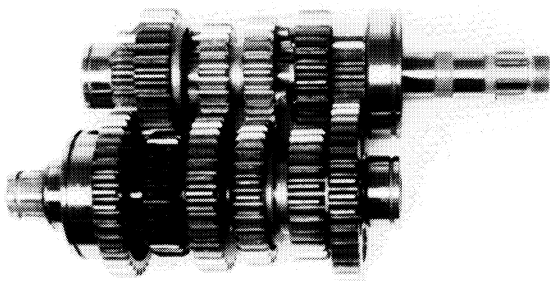

6. Check:

- Proper gear engagement (Each gear) (to its counter part)
- Incorrect → Reassemble.
- Gear movement
- Roughness → Replace.



HY-VO CHAIN GUIDE AND TENSIONER

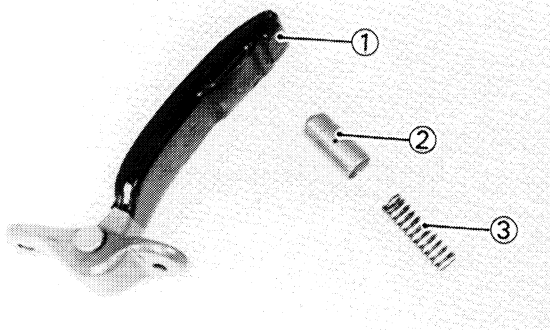

1. Check:

- HY-VO chain guide ①
 - Tensioner plunger ②
 - Spring ③
- Damage/Wear → Replace.

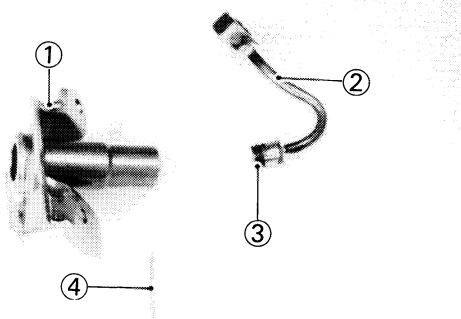

2. Check:

- HY-VO chain tensioner ①
 - Oil delivery pipe ②
 - O-ring ③
 - Cotter pin ④
- Damage → Replace.

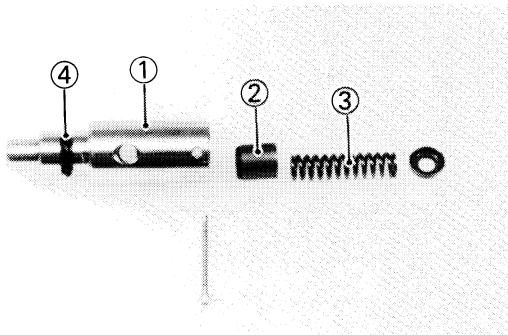

RELIEF VALVES

1. Check:

- Relief valve body ①
 - Plunger ②
 - Spring ③
 - O-ring ④
- Damage/Wear → Replace.

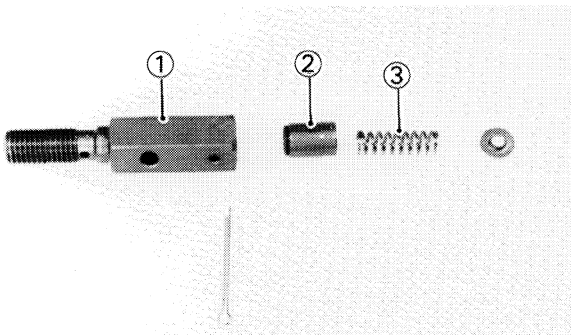

2. Check:

- Tensioner side relief valve body ①
 - Plunger ②
 - Spring ③
- Damage/Wear → Replace.

CRANKCASE

1. Inspect:

- Case halves
 - Bearing seat
 - Fitting
- Damage → Replace.

**BEARINGS AND OIL SEALS**

1. Inspect:

- Bearing
Clean and lubricate, then rotate inner race with finger.
Roughness → Replace bearing (see Removal).

2. Inspect:

- Oil seals
Damage/Wear → Replace (see Removal).

CIRCLIPS AND WASHERS

1. Inspect:

- Circlips
- Washers
Damage/Looseness/Bends → Replace.



SHIFTER

- ① Guide bar
- ② Shift fork (#3)
- ③ Shift fork (#2)
- ④ Shift fork (#1)
- ⑤ Shift cam assembly

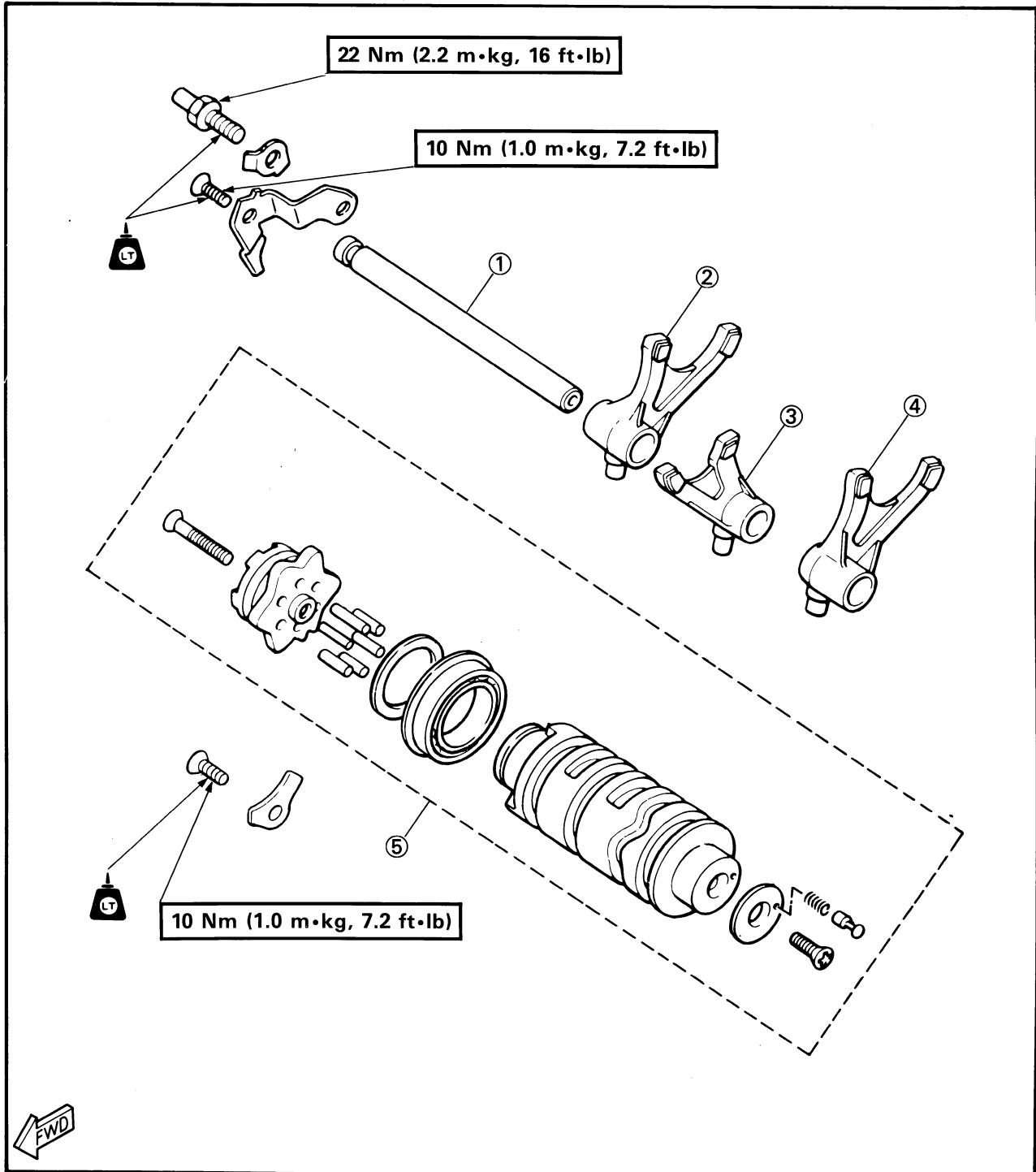

3

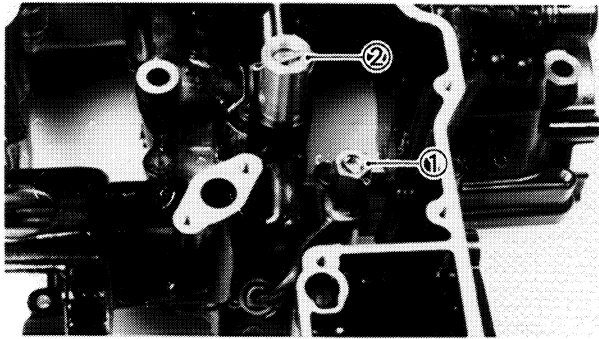

ENGINE ASSEMBLY AND ADJUSTMENT

LOWER CRANKCASE

1. Install:

- Tensioner side relief valve ①
- Copper washers



20 Nm (2.0 m•kg, 14 ft•lb)

- Relief valve ②
- Strainer housing ③
- Screws ④

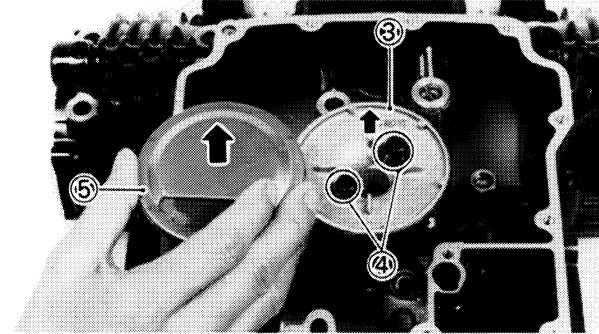

10 Nm (1.0 m•kg, 7.2 ft•lb)

- Oil strainer ⑤

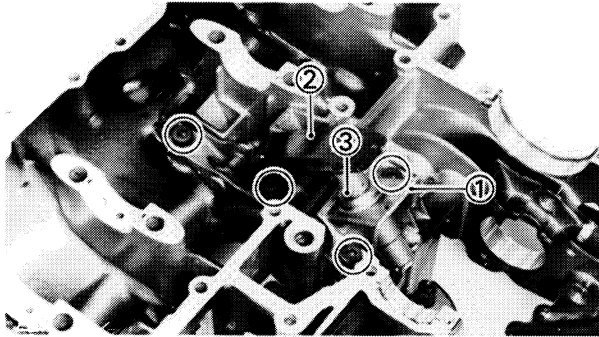

2. Install:

- HV-VO chain tensioner ①



Screw:

10 Nm (1.0 m•kg, 7.2 ft•lb)
Apply LOCTITE®

- HV-VO chain guide ②
- Spring
- Tensioner plunger ③

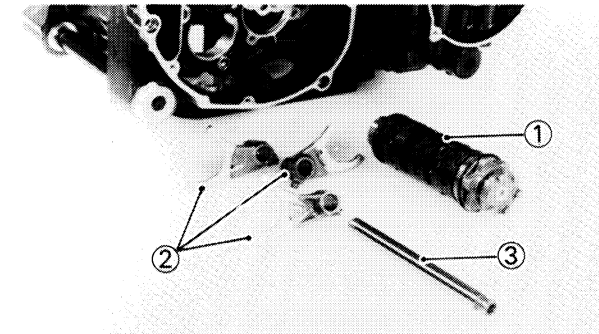

3. Install:

- Shift cam assembly ①
- Shift forks ②
- Guide bar ③

NOTE:

All shift fork numbers should face the right side and be in sequence (1,2,3) beginning from the right.

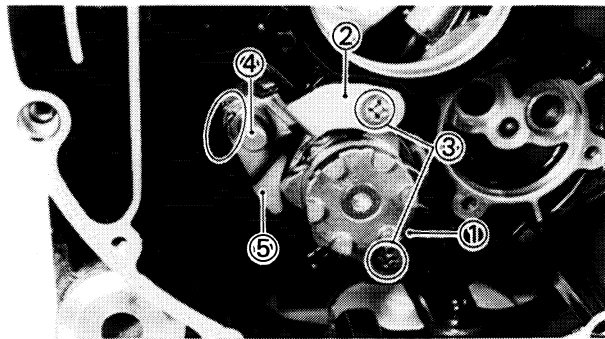

4. Install:

- Bearing stopper ①
- Guide bar stopper ②
- Screws ③



10 Nm (1.0 m•kg, 7.2 ft•lb)
Apply LOCTITE®.

- Stopper screw ④



22 Nm (2.2 m•kg, 16 ft•lb)
Apply LOCTITE®.

- Lock washer ⑤

NOTE: _____

Bend lockwasher tab along nut flat.

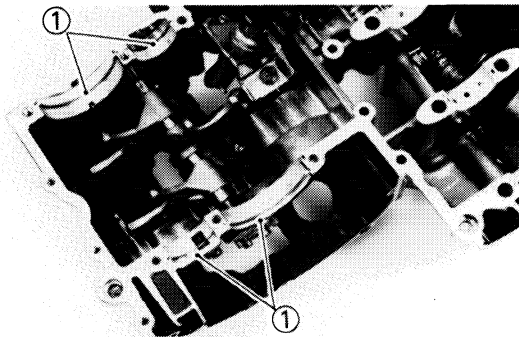

5. Install:

- Circlips ①
- Oil seal

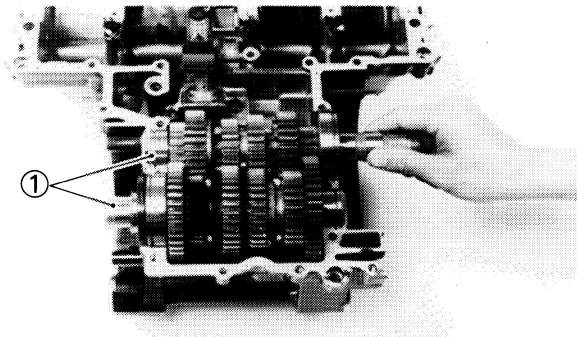

6. Install:

- Transmission assembly ①

NOTE: _____

Be sure axle circlips are fitted to bearings and circlips have been positioned in circlip grooves.

7. Check:

- Shifter operation.
Unsmooth operation → Repair.
- Transmission operation
Unsmooth operation → Repair.



STARTER

- ① Primary drive gear
- ② Starter idle gear
- ③ Bearing
- ④ Starter clutch
- ⑤ Starter clutch damper assembly
- ⑥ HY-VO chain
- ⑦ A.C.G. shaft
- ⑧ HY-VO chain guide

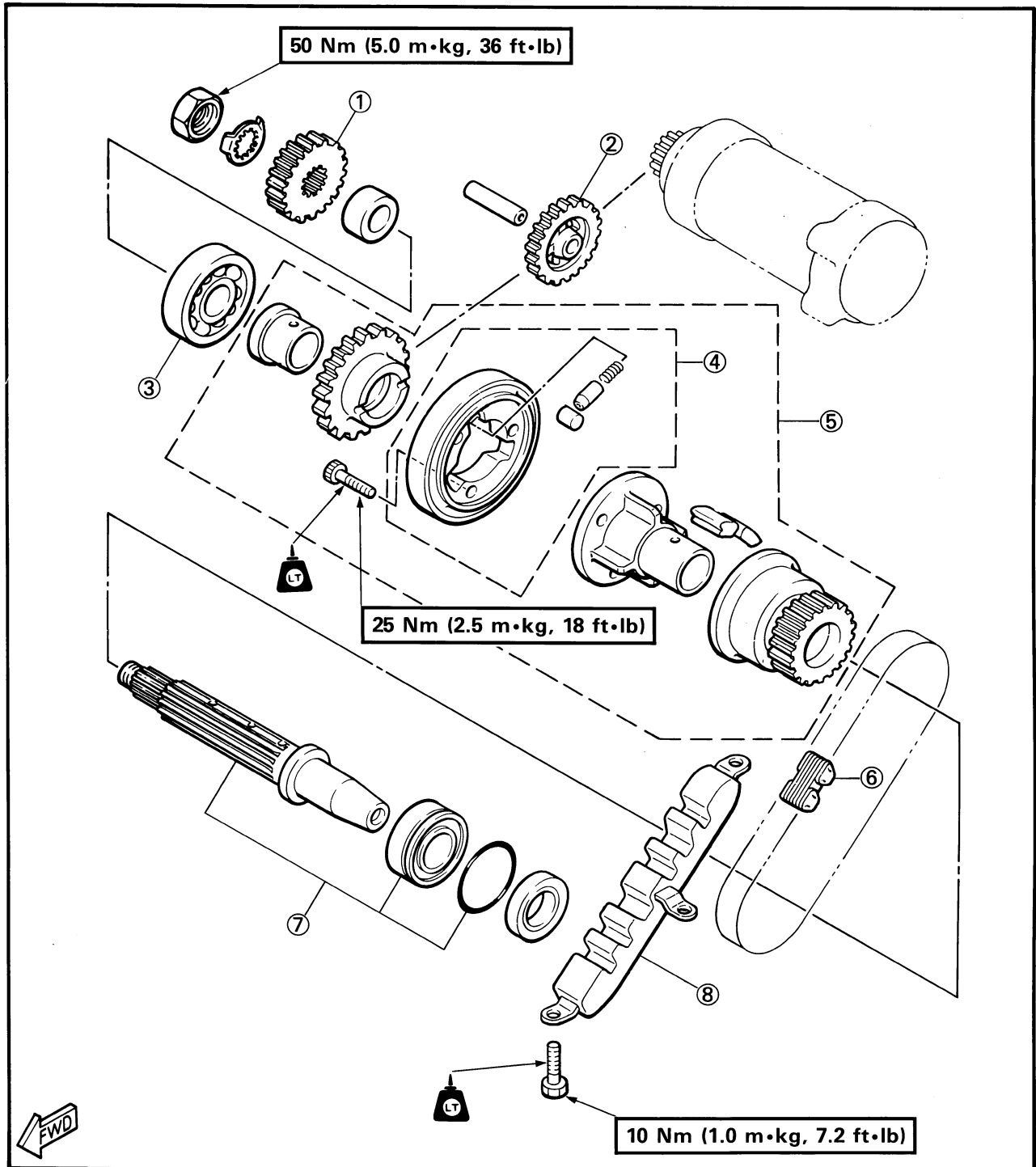



CRANKSHAFT

- ① Connecting rod
- ② Big end cap
- ③ Bearing
- ④ Crankshaft assembly
- ⑤ Bearing
- ⑥ Oil seal

A	CRANKSHAFT RUNOUT LIMIT: 0.03 mm (0.0012 in)
B	CONNECTING ROD BEARING CLEARANCE: 0.016 ~ 0.040 mm (0.0006 ~ 0.0016 in)

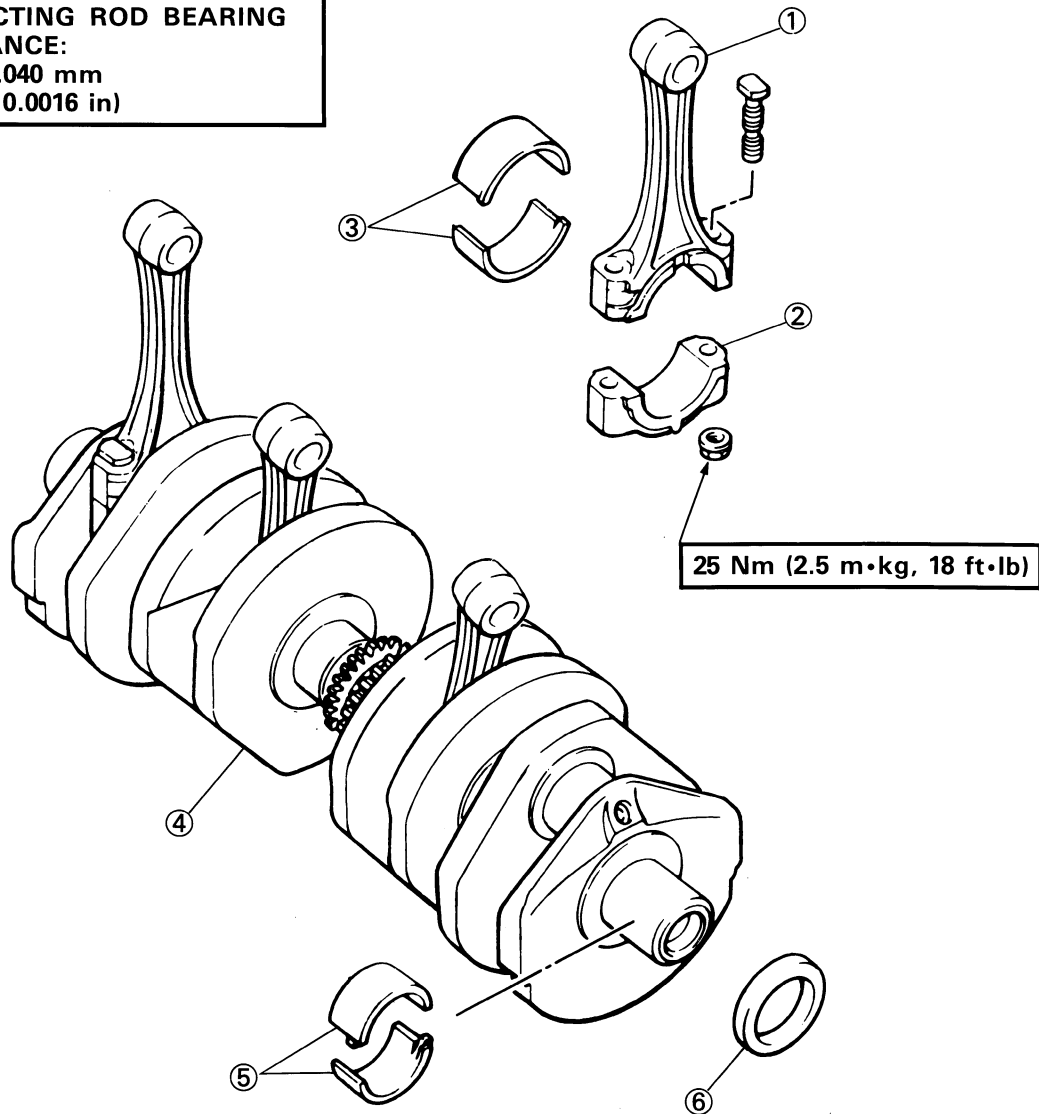

C	MAIN BEARING OIL CLEARANCE: 0.021 ~ 0.044 mm (0.0008 ~ 0.0017 in)
----------	--

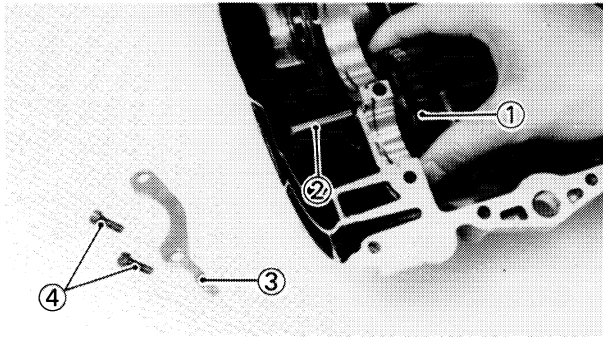

UPPER CRANKCASE

1. Install:

- Starter idle gear ①
- Shaft ②
- Bearing stopper ③
- Screws ④

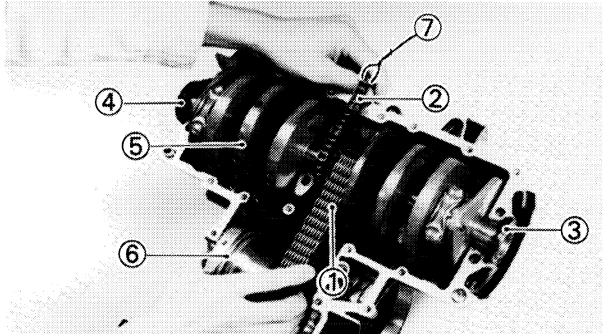

2. Install:

- HY-VO chain ①
- Cam chain ②
- Oil seal ③
- Plug ④
(onto crankshaft)
- Crankshaft assembly ⑤
- Starter clutch damper assembly ⑥

NOTE:

- The crankshaft pin (timing plate stopper pin) should face to the left.
- Pass the cam chain through the cam chain cavity. Be sure to attach a retaining wire ⑦ to the cam chain.

3

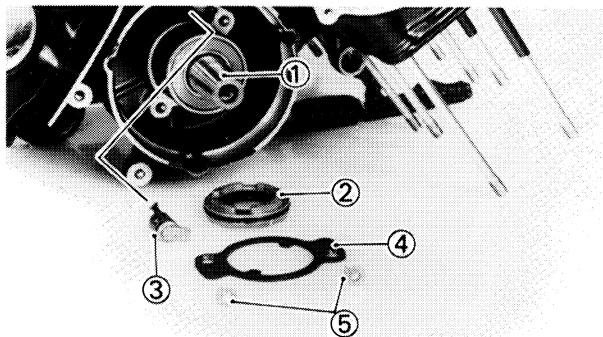

3. Install:

- A.C.G shaft ①
- Bearing housing ②
- Oil spray nozzle ③
- Cover plate ④
- Screw ⑤



10 Nm (1.0 m•kg, 7.2 ft•lb)
Apply **LOCTITE®**.

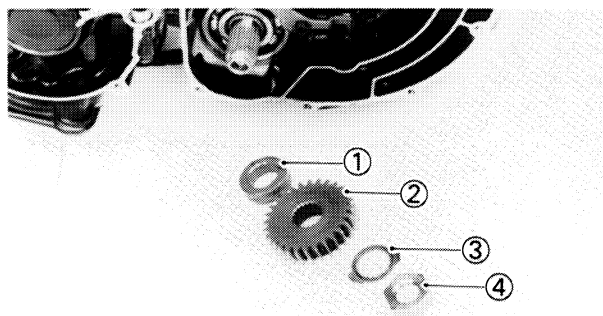

4. Install:

- Collar ①
- Primary drive gear ②
- Lock washer ③
- Nut ④

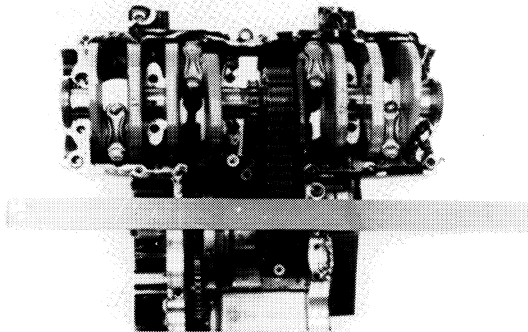
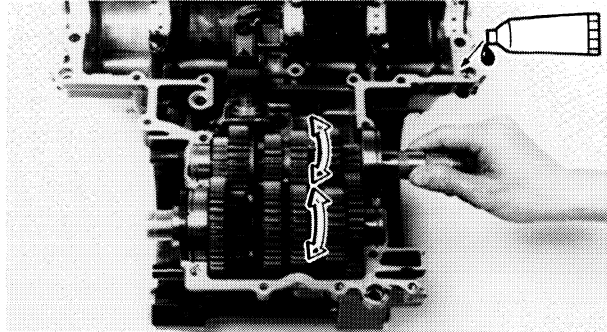
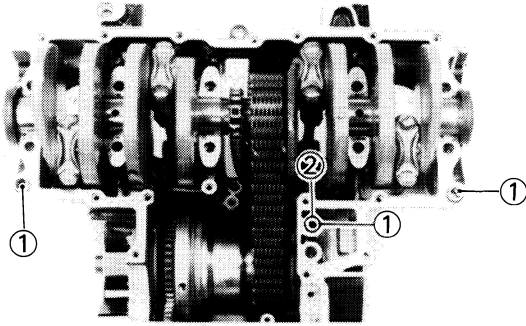

5. Install:

- Dowel pins ①
- O-ring ②

CRANKCASE ASSEMBLY

1. Apply Quick Gasket® (ACC-11001-05-01) to crankcase matching surfaces.

NOTE:

DO NOT ALLOW any sealant to come in contact with the oil gallery O-ring, or crankshaft bearings. Do not apply sealant to within 2~3 mm (0.08~0.12 in) of the bearings.

2. Set shift cam and transmission gears in NEUTRAL position.
3. Place suitable bar on the upper crankcase.

4. Place lower crankcase assembly on the upper crankcase assembly.

NOTE:

Push HY-VO chain damper to prevent tensioner plunger from falling into crankcase cavity.

5. Install:

- Lower crankcase

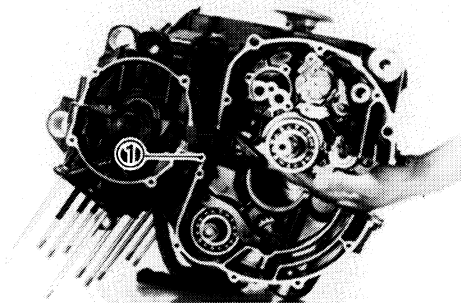



CAUTION:

Before tightening the crankcase bolts, check the following points:

- Remove bar ①.
- Be sure the gear shifts correctly while hand-turning the shift cam.

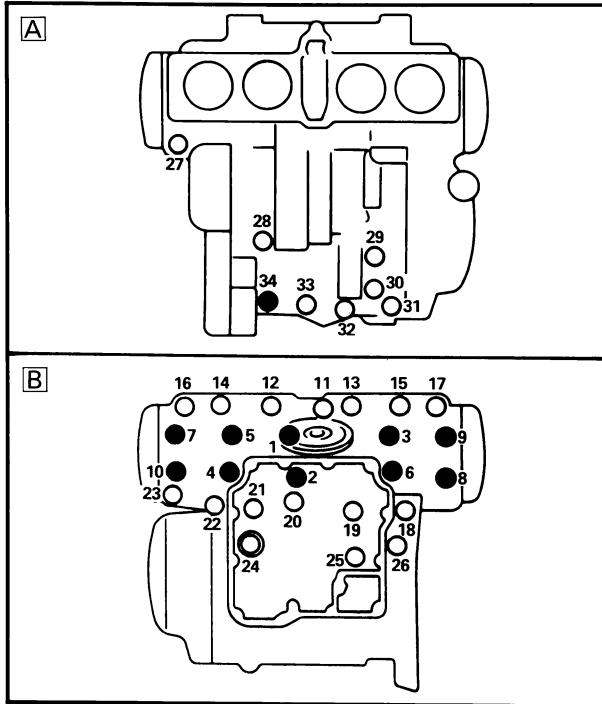

6. Tighten:

- Lower crankcase bolt **B**
 - Upper crankcase bolt **A**
- (Follow proper tightening sequence.)

	• 6 mm (0.24 in): 12 Nm (1.2 m•kg, 8.7 ft•lb)
	• 8 mm (0.31 in): 24 Nm (2.4 m•kg, 17 ft•lb)

3

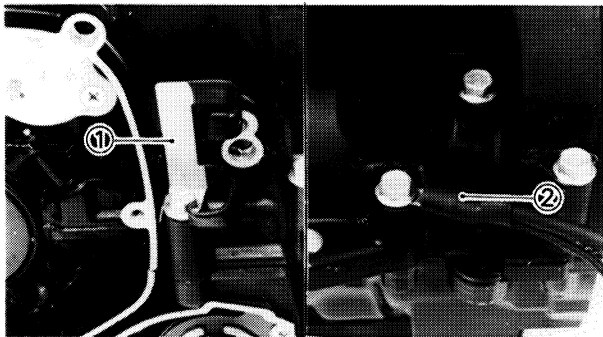

NOTE:

- Install the clamp ① on Bolt No. 26.
- Install the ground lead ② on Bolt No. 32.

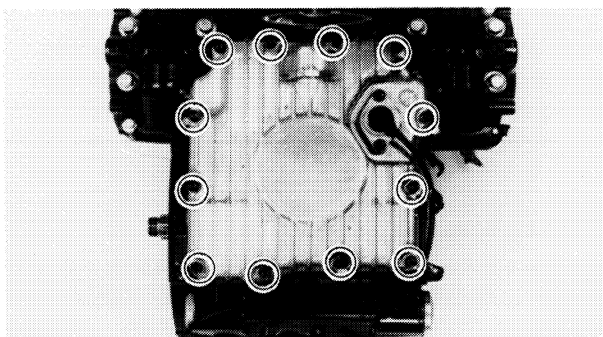

7. Install:

- Oil pan

	10 Nm (1.0 m•kg, 7.2 ft•lb)
---	-----------------------------

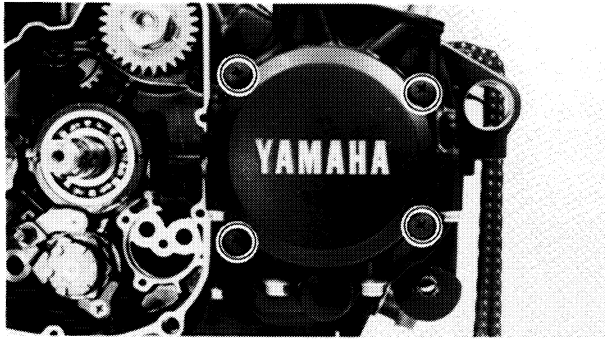

8. Install:

- Right-front crankcase cover



10 Nm (1.0 m•kg, 7.2 ft•lb)

OIL PUMP

- ① Oil pump drive gear
- ② Shaft
- ③ Pin
- ④ Oil pump housing
- ⑤ Rotor
- ⑥ Pump cover
- ⑦ O-ring

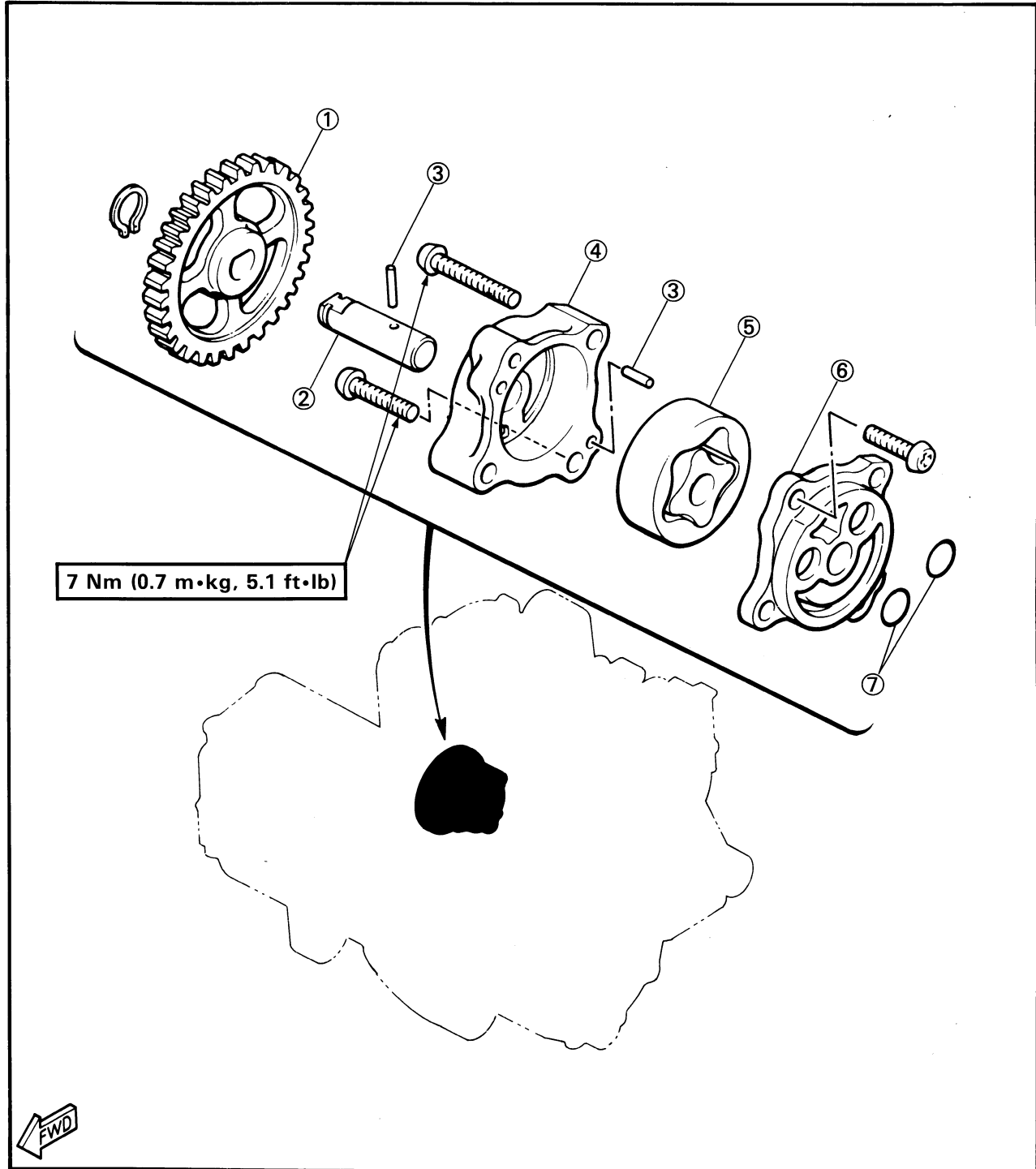

SHIFT SHAFT

- ① Shift shaft
- ② Collar
- ③ Spring
- ④ Circlip
- ⑤ Plain washer
- ⑥ Stopper lever
- ⑦ Spring
- ⑧ Plain washer
- ⑨ Oil seal
- ⑩ Plain washer
- ⑪ Collar
- ⑫ Change pedal

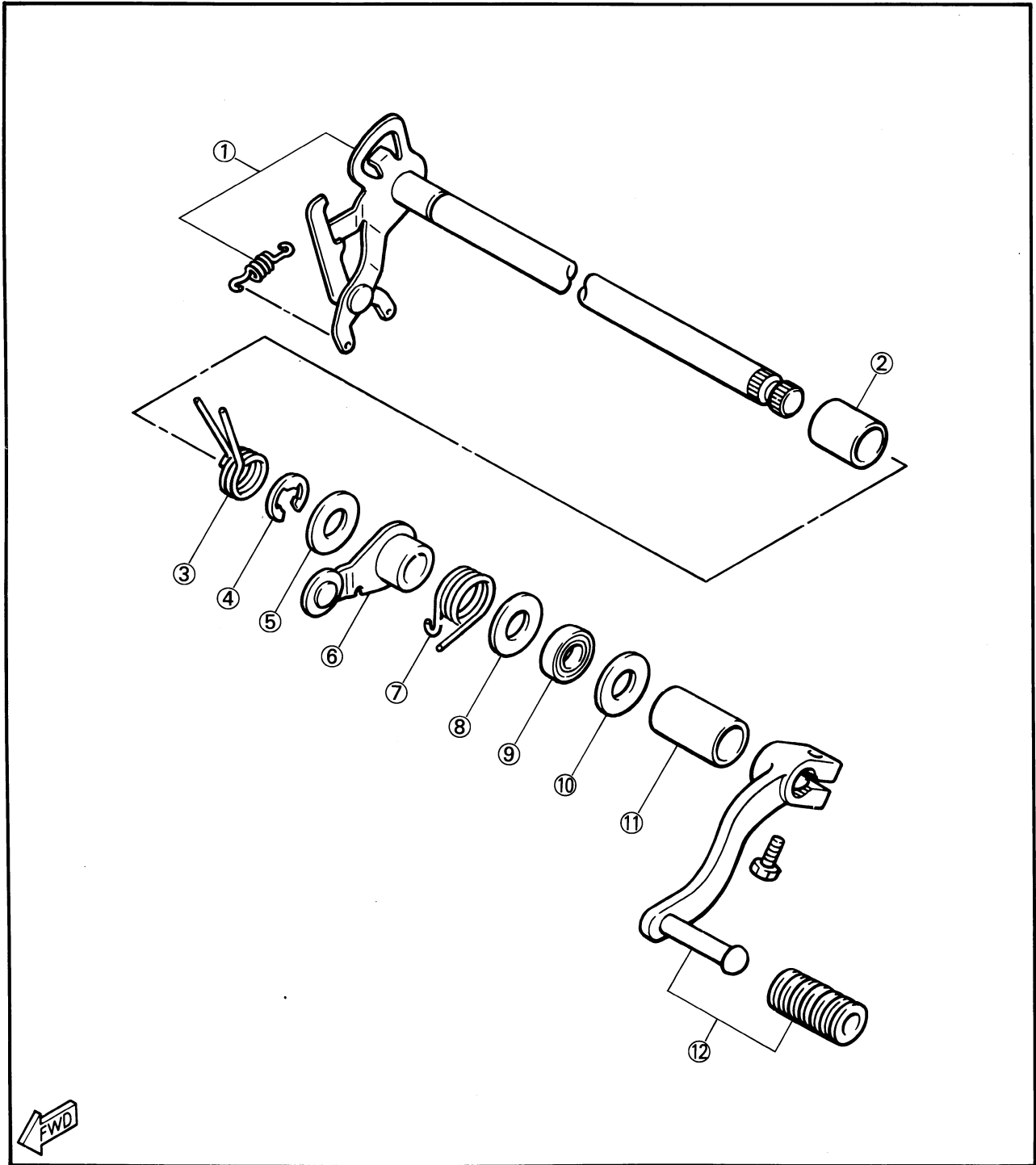

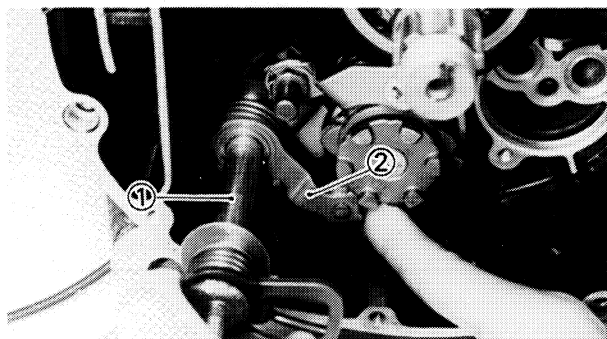

OIL PUMP AND SHIFT SHAFT

1. Install:

- Shift shaft assembly ①

2. Mesh the stopper lever ② with shift cam stopper.

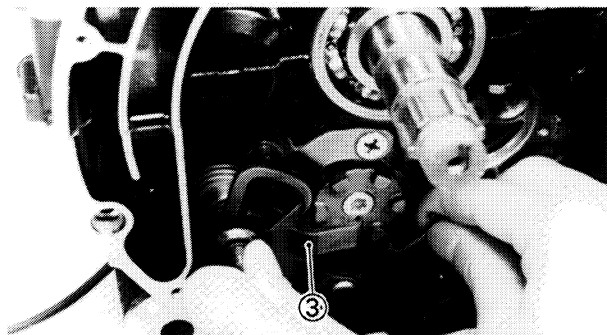

3. Pull the shift lever 2 ③ and push shift shaft assembly.

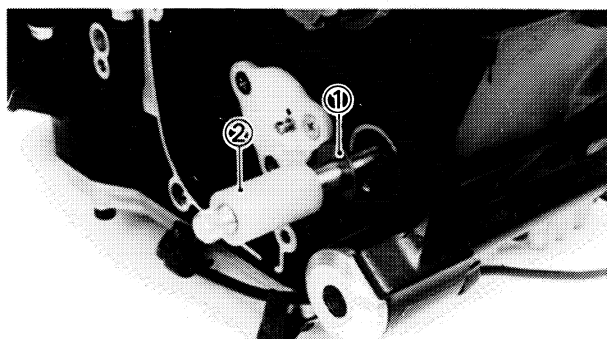

4. Install:

- Plate washer ①
- Collar ②
(on left side shift shaft)

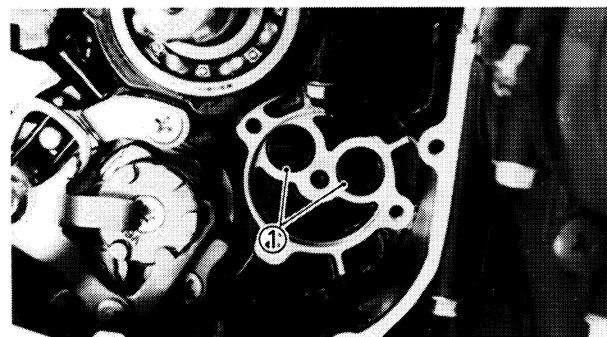

5. Install:

- O-rings ①
- Oil pump assembly ②



7 Nm (0.7 m•kg, 5.1 ft•lb)

- Oil pump driven gear ③
- Circlip ④

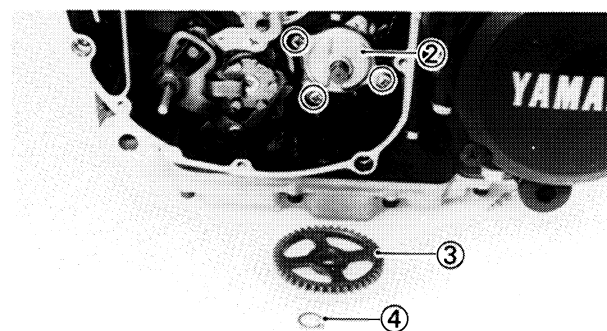



CLUTCH

- ① Plate washer
- ② Oil seal
- ③ Circlip
- ④ Lock washer
- ⑤ Clutch plate (#1)
- ⑥ Friction plate (#1)
- ⑦ Wire clip
- ⑧ Clutch plate
- ⑨ Clutch boss spring
- ⑩ Seat
- ⑪ Thrust plate
- ⑫ Bearing
- ⑬ Pull rod
- ⑭ Match mark

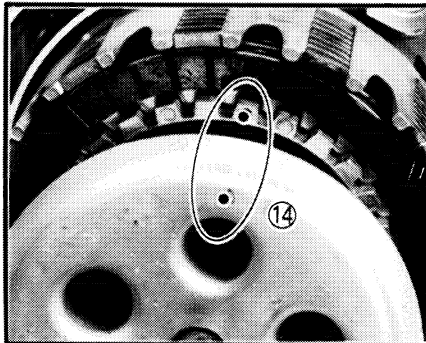

D CLUTCH PLATE POSITION

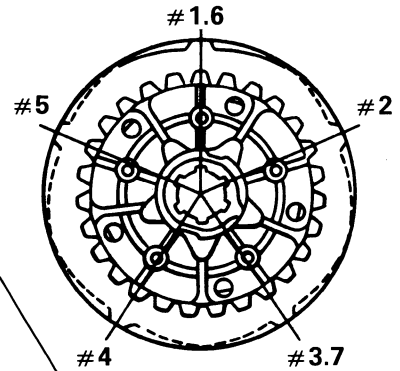

70 Nm (7.0 m·kg, 50 ft·lb)

8 Nm (0.8 m·kg, 5.8 ft·lb)

**A SPRING FREE LENGTH LIMIT:
41.8 mm (1.64 in)**

**B CLUTCH PLATE WARP LIMIT:
0.15 mm (0.006 in)**

**C FRICTION PLATE WEAR LIMIT:
2.7 mm (0.106 in)**



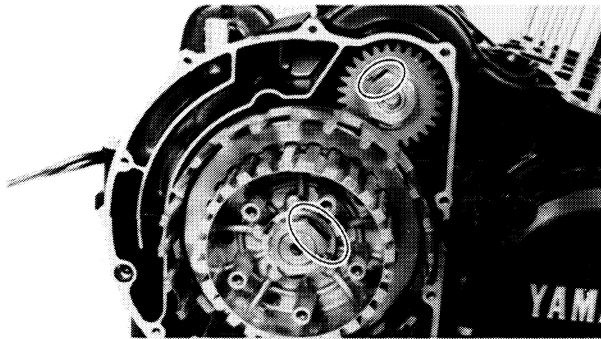
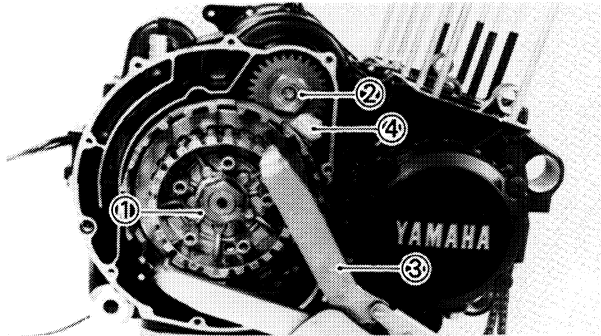
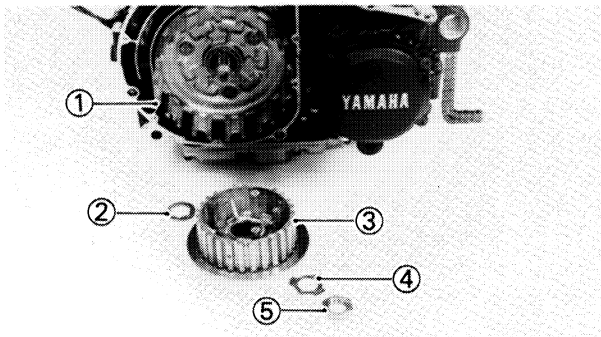

CLUTCH

1. Install:

- Clutch housing ①
- Thrust washer ②
- Clutch boss ③
- Lock washer ④
- Nut ⑤

2. Tighten:

- Nut ① (clutch boss)
Use Universal Clutch Holder (YM-91042) ③.
- Nut ② (Primary drive gear)
Place the folded rag ④ between the teeth of the drive gear and driven gear to lock them.

	Nut (Clutch Boss):
	70 Nm (7.0 m•kg, 50 ft•lb)
	Nut (Primary Drive Gear):
	50 Nm (5.0 m•kg, 36 ft•lb)

3

NOTE:

Bend the lock washer tab along the nut flat.

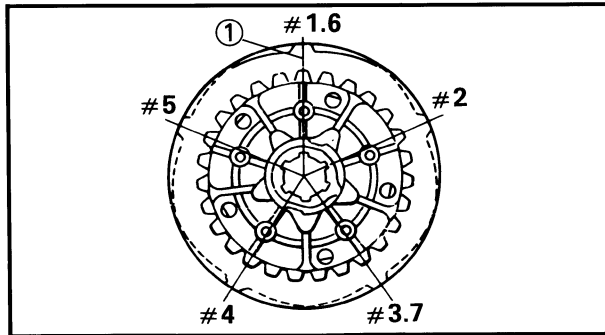

3. Install:

- Friction plates
- Clutch plates

NOTE:

- Mount friction and clutch plates alternately.
- Align the clutch plate mark ① as shown.

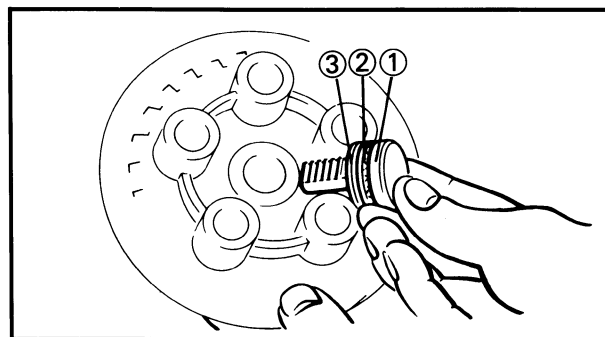

4. Install:

- Thrust bearing ②
- Plate washer ③
(on the pull rod)
- Pull rod ①
(into the pressure plate)

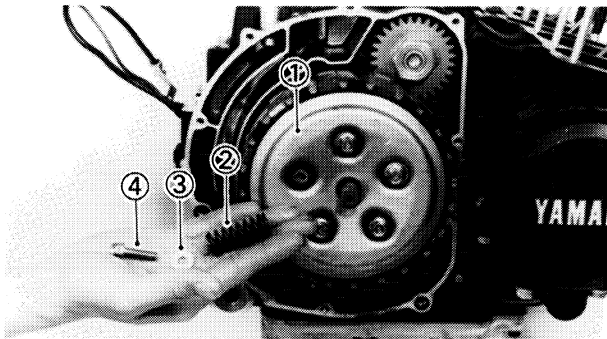

5. Install:

- Pressure plate ①
- Spring ②
- Plate washer ③
- Bolt ④



8 Nm (0.8 m•kg, 5.8 ft•lb)

NOTE:

Align the pressure plate mark ① with the clutch boss mark ②.

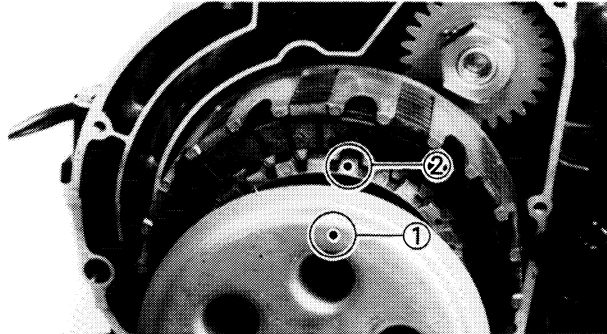

6. Install:

- Gasket ①
- Dowel pins ②
- Right crankcase cover ③



10 Nm (1.0 m•kg, 7.2 ft•lb)

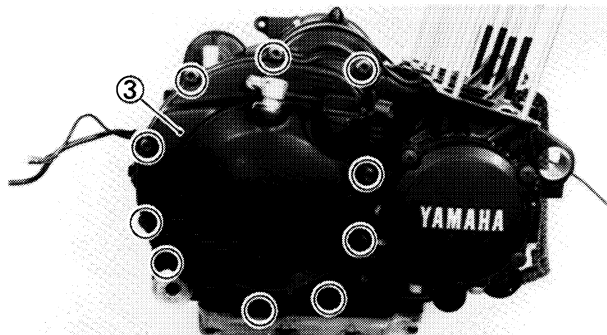
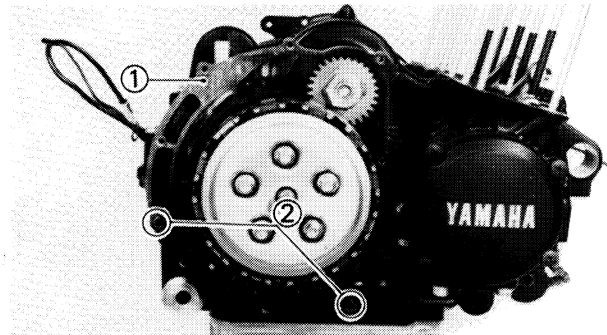

NOTE:

Be sure the pull rod gear ① face to rear of engine.

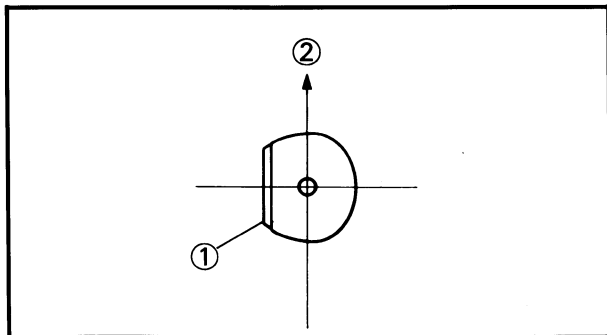

② Upper

GENERATOR

- ① Starter coil
- ② Rotor
- ③ Brush assembly

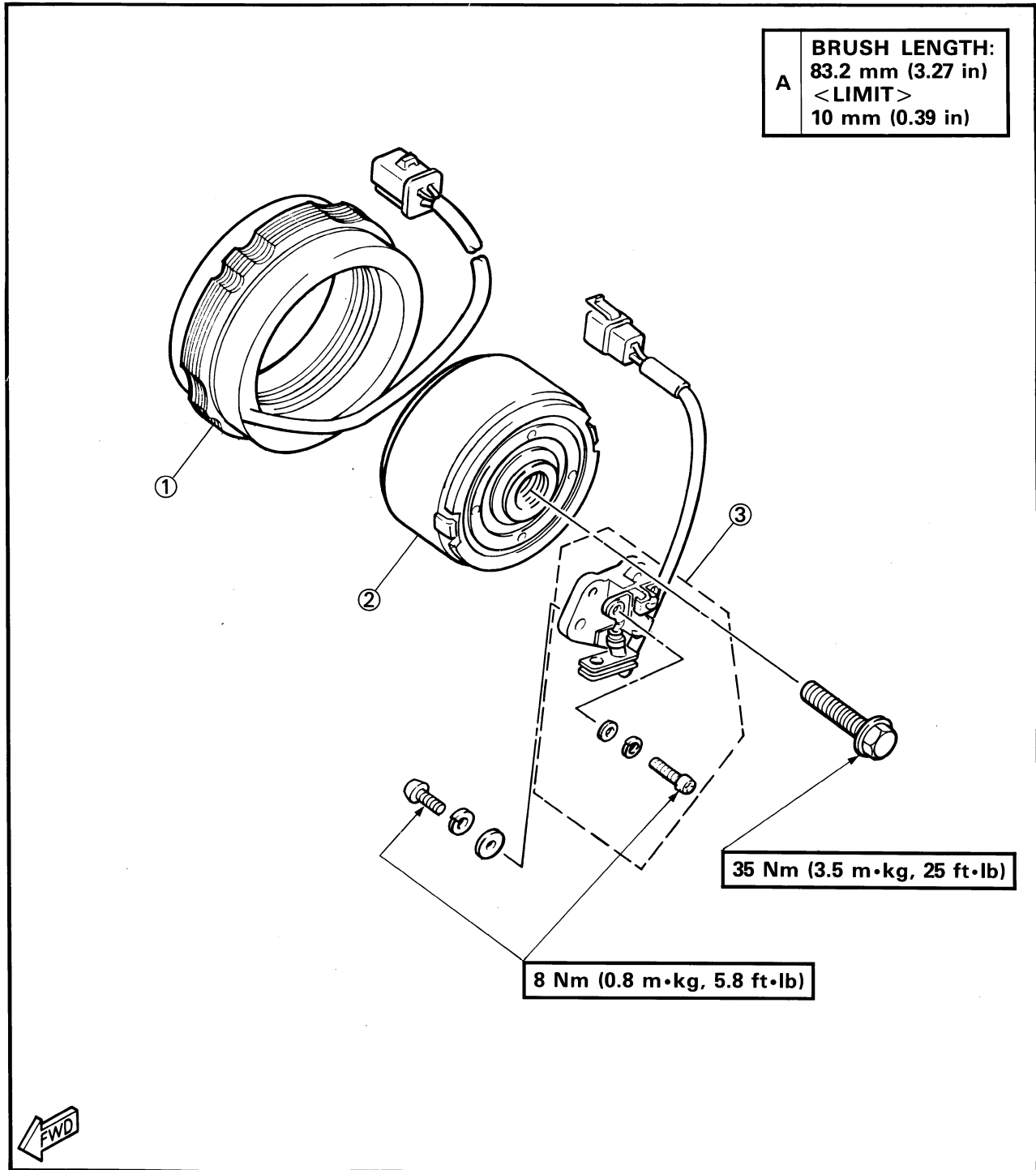

3



PICKUP COIL

- ① Pickup coil assembly
- ② Pin
- ③ Timing plate

A PICKUP COIL RESISTANCE:
108 ~ 132Ω at 20°C (68°F)

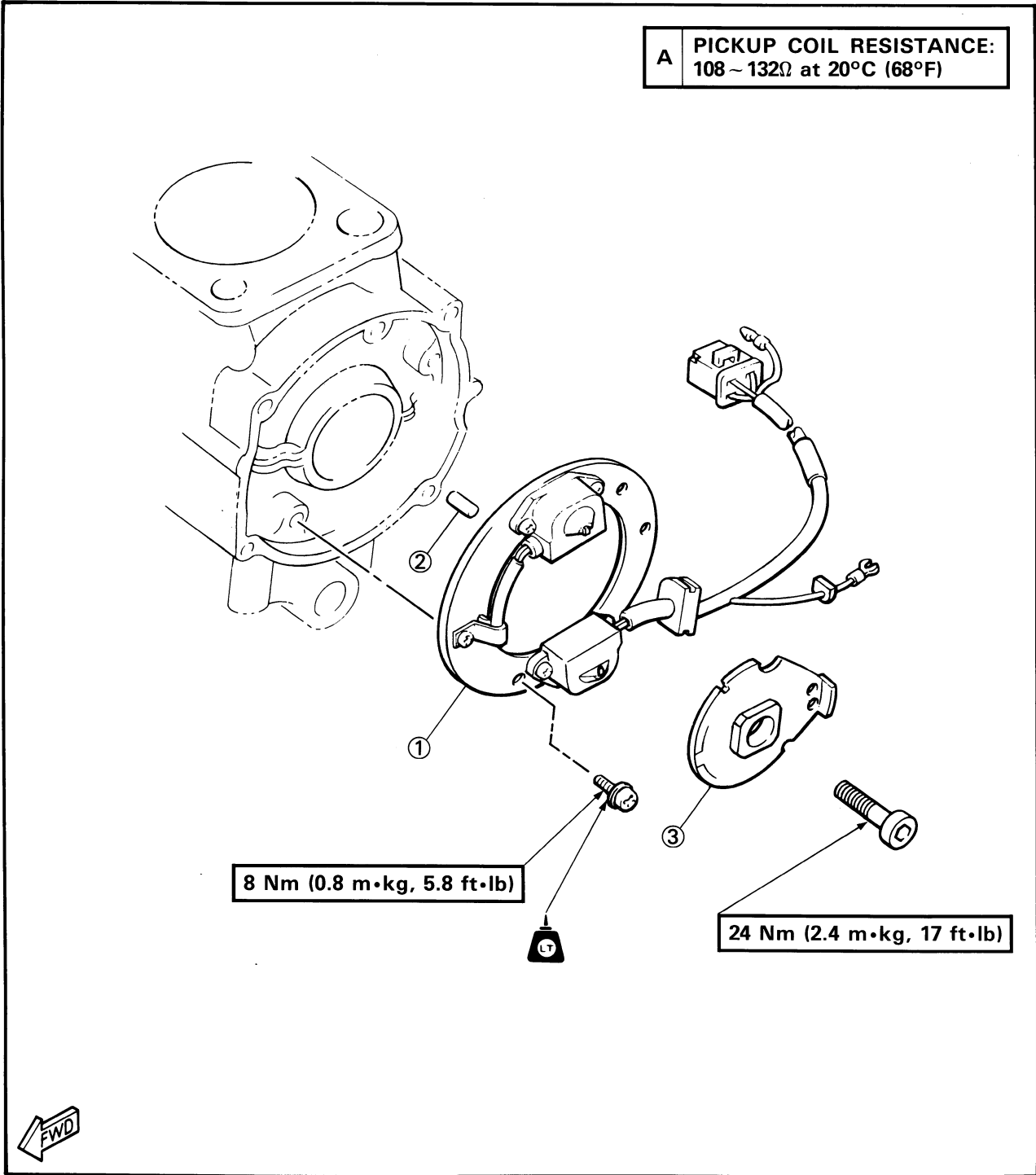

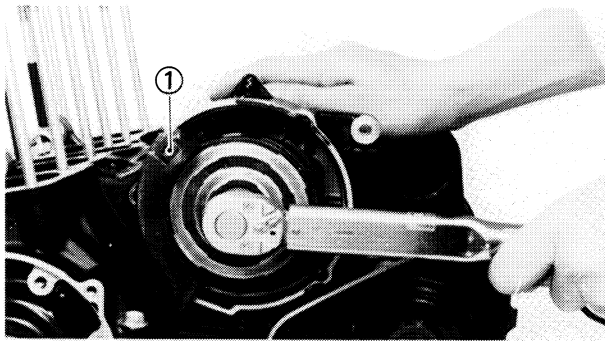

PICKUP COIL AND GENERATOR

1. Install:

- Rotor
- Bolt

Use Rotor Holding Tool (YM-04043) ①.



35 Nm (3.5 m•kg, 25 ft•lb)

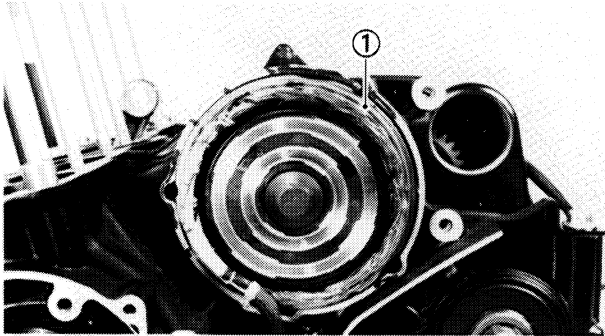

2. Install:

- Stator coil ①

NOTE: _____

Align the stator core grooves with the bolt holes.

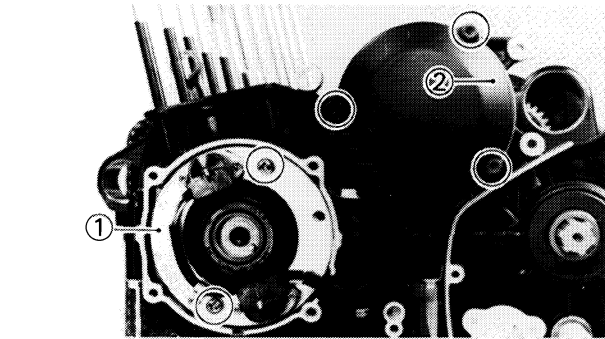

3. Install:

- Generator cover ②
- Pickup coil assembly ①



**Screw (Pickup Coil Assembly):
8 Nm (0.8 m•kg, 5.8 ft•lb)
Apply LOCTITE®.**

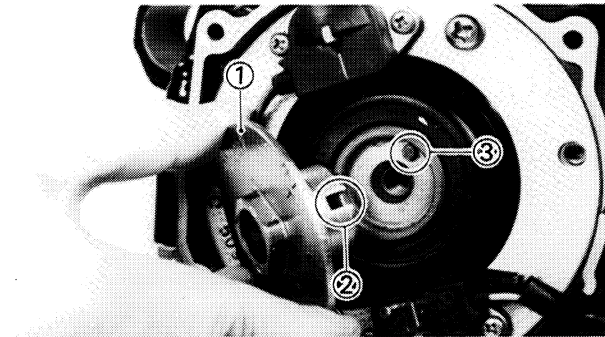

4. Install:

- Timing plate ①
- Screw



24 Nm (2.4 m•kg, 17 ft•lb)

Mesh the timing plate groove ② with the crankshaft pin ③.

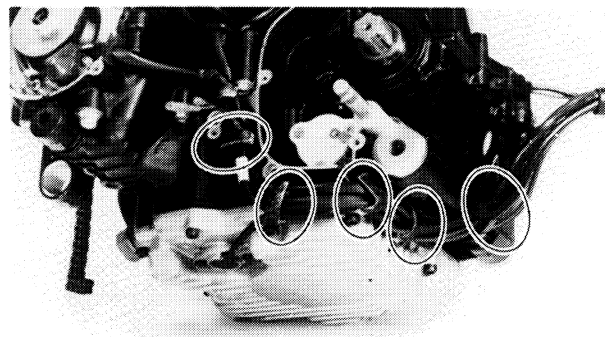

5. Clamp the A.C.G. leads and pickup leads.



PISTON

- ① Top ring
- ② Second ring
- ③ Oil ring
- ④ Circlip
- ⑤ Piston pin
- ⑥ Piston
- ⑦ Top ring
- ⑧ Oil ring (Lower rail)
- ⑨ Second ring
- ⑩ Oil ring (Upper rail)

D PISTON RING INSTALLATION

A	PISTON RING END GAP:
	TOP AND 2nd: 0.15 ~ 0.30 mm (0.0059 ~ 0.0118 in) OIL: 0.2 ~ 0.7 mm (0.008 ~ 0.028 in)
B	PISTON RING SIDE CLEARANCE:
	TOP: 0.03 ~ 0.07 mm (0.0012 ~ 0.0028 in) 2nd: 0.02 ~ 0.06 mm (0.0008 ~ 0.0024 in)
C	PISTON CLEARANCE:
	0.025 ~ 0.045 mm (0.0010 ~ 0.0019 in)



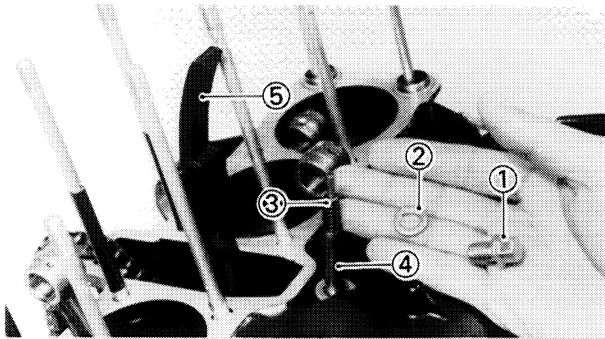

PISTON AND INTAKE SIDE CAM CHAIN GUIDE

1. Install:

- Intake side cam chain guide ①
- Stopper shaft ②
- Spring ③
- Plate washer
- Bolt ④

NOTE:

The lower end of chain guide must rest in the cam chain guide slot in the crankcase.

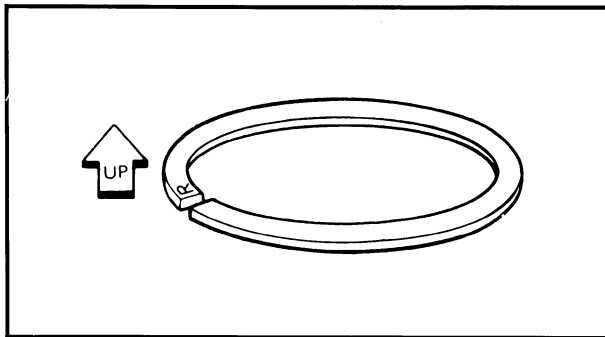

2. Install:

- Piston rings

NOTE:

Be sure to install rings so that Manufacturer's marks or numbers are located on the top side of the rings. Oil the pistons and rings liberally.

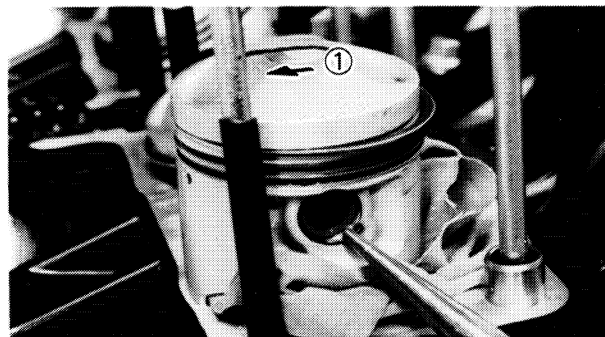

3. Install:

- Piston pin
- Piston
- Piston pin circlip (New)

NOTE:

- Be sure the piston arrow mark ① face to exhaust side.
- Before installing piston pin circlip, cover crankcase with a clean rag to prevent circlip from falling into crankcase cavity.
- Be sure the marked piston numbers ② should be in sequence (1,2,3,4) beginning from the left.

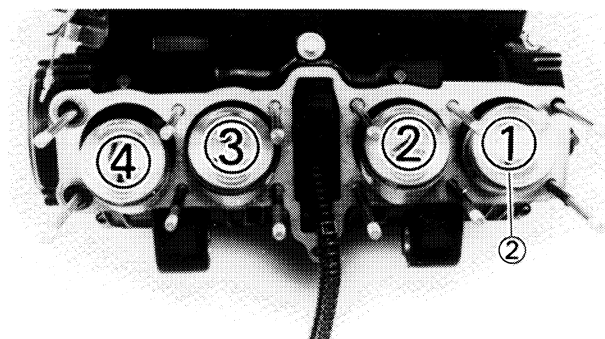

CYLINDER

- ① Cylinder
- ② O-ring
- ③ Gasket
- ④ Dowel pin
- ⑤ O-ring

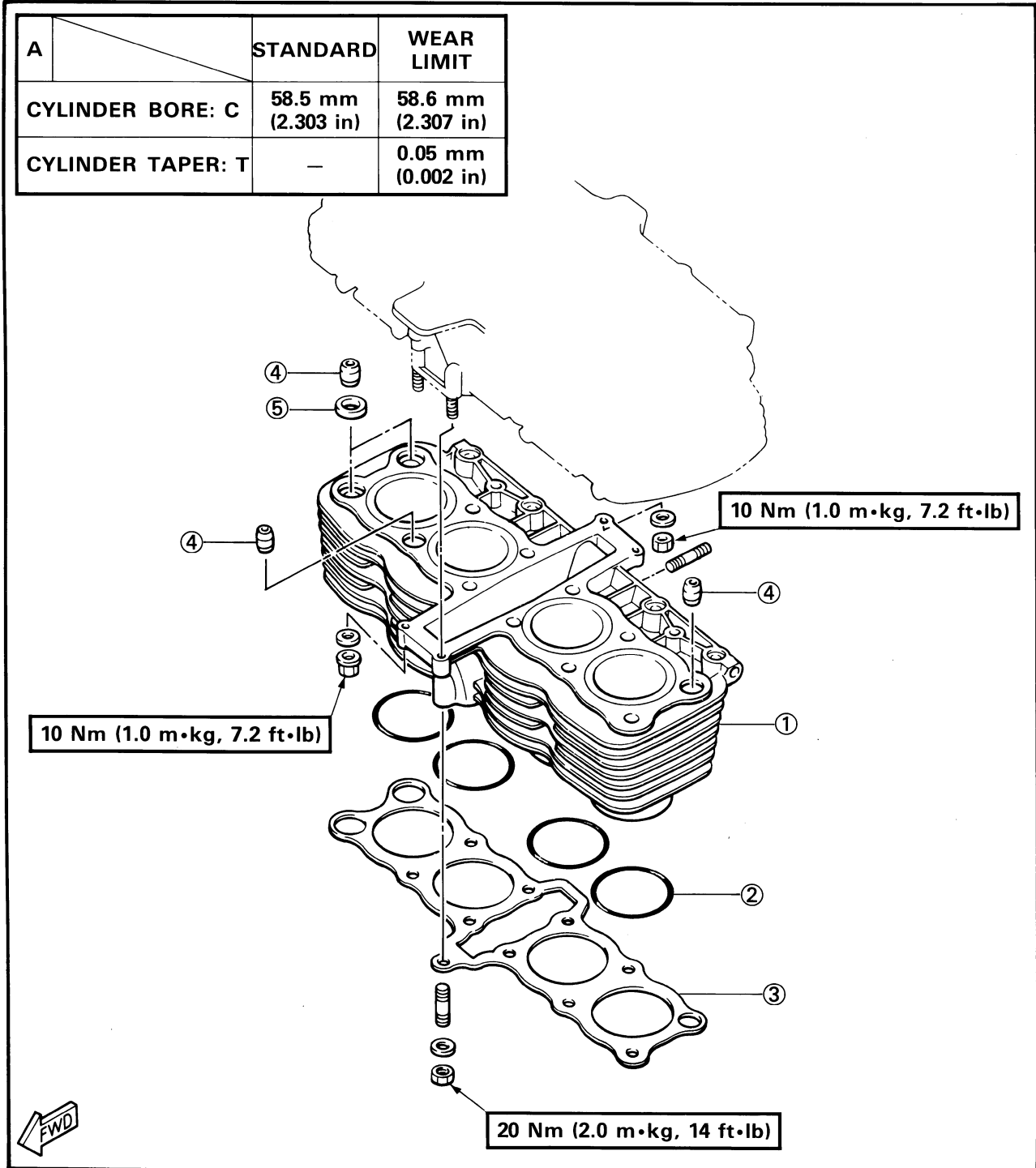

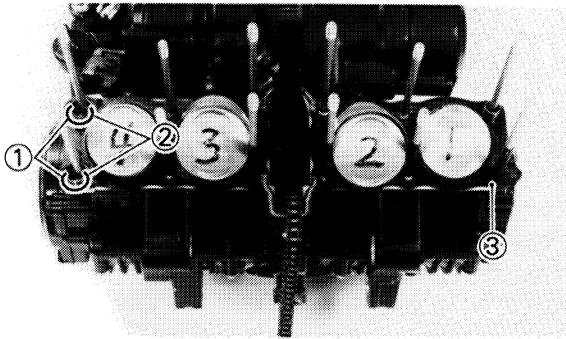

CYLINDER

1. Install:

- Dowel pins ①
- O-rings ②
- Cylinder gasket ③

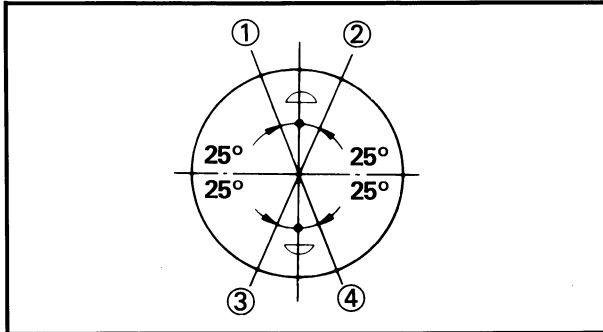

2. Oil liberally:

- Piston
- Rings
- Cylinders

3. Set:

- Top ring end ①
- Oil ring end (Lower) ②
- Oil ring end (Upper) ③
- 2nd ring end ④

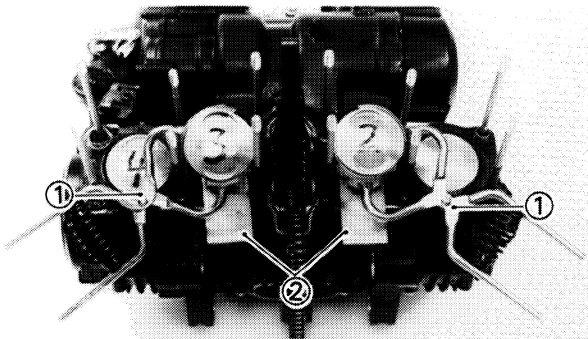

4. Install:

- Cylinder
- Use Piston Ring Compressor ① (YM-04047) and Piston Base ② (YM-01067).

Pass the cam chain and exhaust side cam chain guide through cam chain cavity.

5. Tighten:

- Cylinder nut ①



20 Nm (2.0 m•kg, 14 ft•lb)

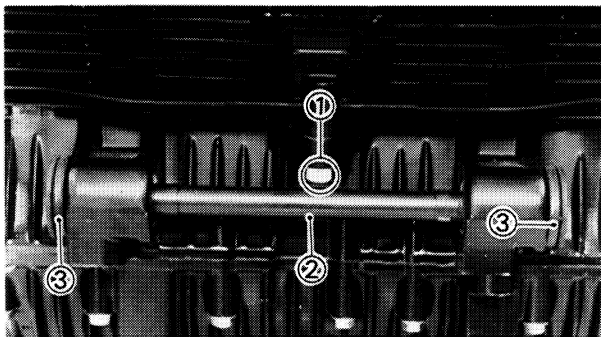

6. Install:

- Front engine mount spacer ②
- Damper ③



CYLINDER HEAD

- ① Washer
- ② Rubber washer
- ③ Gasket
- ④ Spark plug
- ⑤ Valve guide
- ⑥ Circlip
- ⑦ Stud bolt

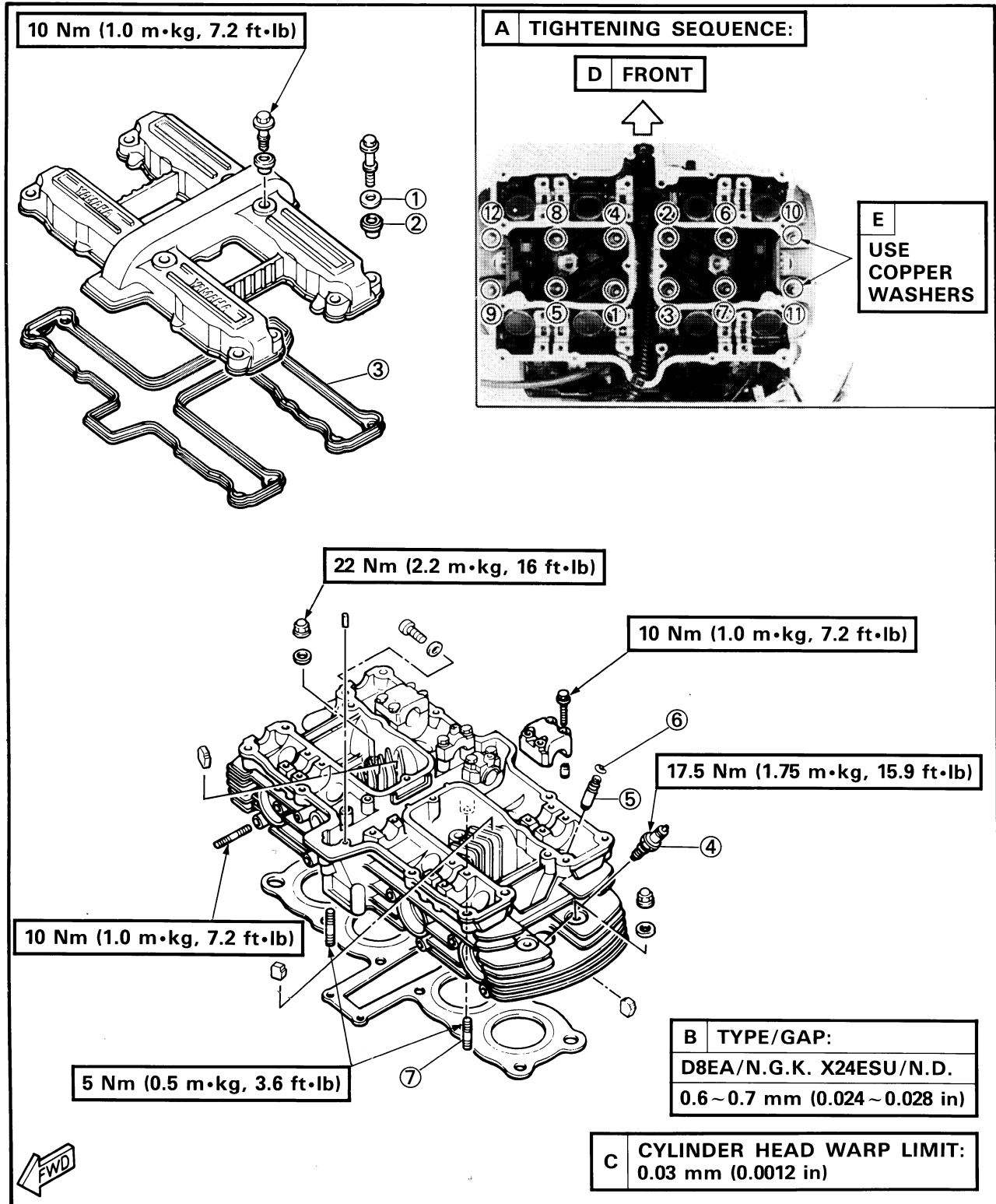

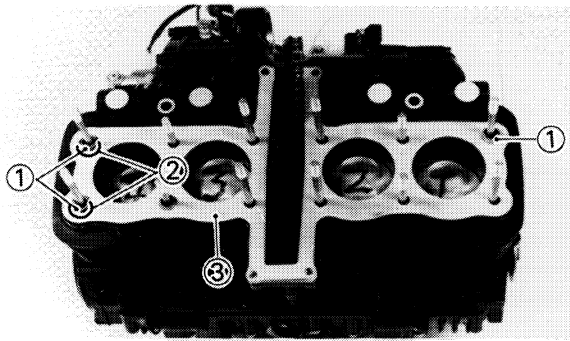

CYLINDER HEAD

1. Install:

- Dowel pins ①
- O-rings ②
- Head gasket ③ (New)
- Cylinder head

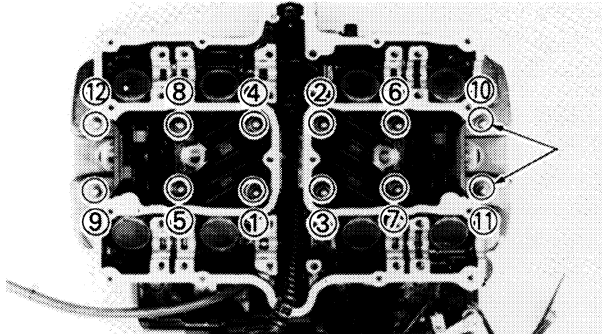

2. Tighten:

- Cylinder head nuts

In sequence as shown and torque nuts in two stages.

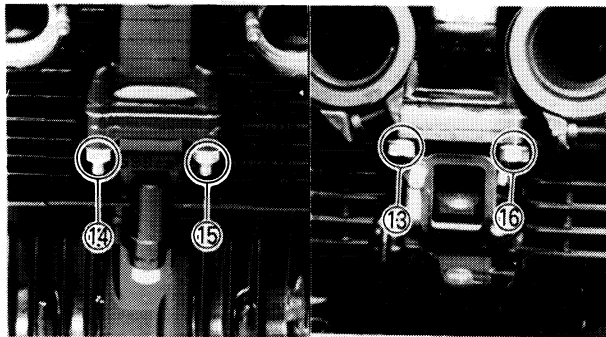

Nut No. ① ~ ⑫:

22 Nm (2.2 m•kg, 16 ft•lb)

Nut No. ⑬ ~ ⑯:

10 Nm (1.0 m•kg, 7.2 ft•lb)

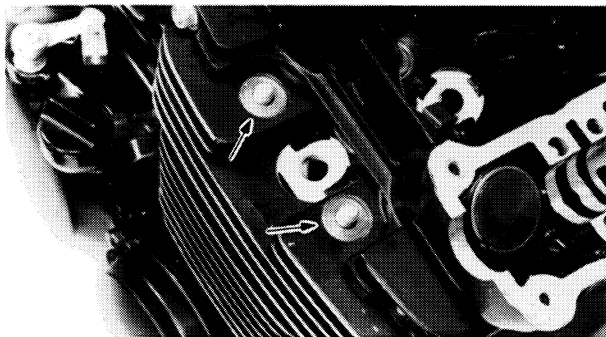

NOTE:

Use copper washers.



CAMSHAFT

- ① Cam chain
- ② Cam sprocket
- ③ Camshaft (Exhaust)
- ④ Camshaft (Intake)
- ⑤ Chain tensioner body
- ⑥ Tensioner lock bolt
- ⑦ Tensioner rod (Large)
- ⑧ Tensioner rod (Small)
- ⑨ Guide stopper plate
- ⑩ Upper chain guide
- ⑪ Exhaust side chain guide
- ⑫ Intake side chain guide
- ⑬ Adjusting pad
- ⑭ Valve lifter
- ⑮ Valve retainer
- ⑯ Spring seat
- ⑰ Inner spring
- ⑱ Outer spring
- ⑲ Spring seat
- ⑳ Oil seal
- ㉑ Valve
- ㉒ Chain guide stopper
- ㉓ Match mark

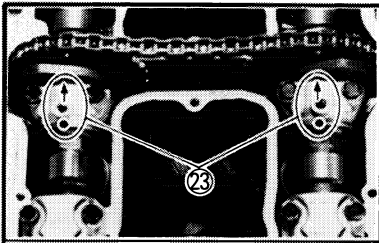

A VALVE CLEARANCE (COLD):	
B INTAKE	0.11 ~ 0.15 mm (0.004 ~ 0.006 in)
C EXHAUST	0.16 ~ 0.20 mm (0.006 ~ 0.008 in)

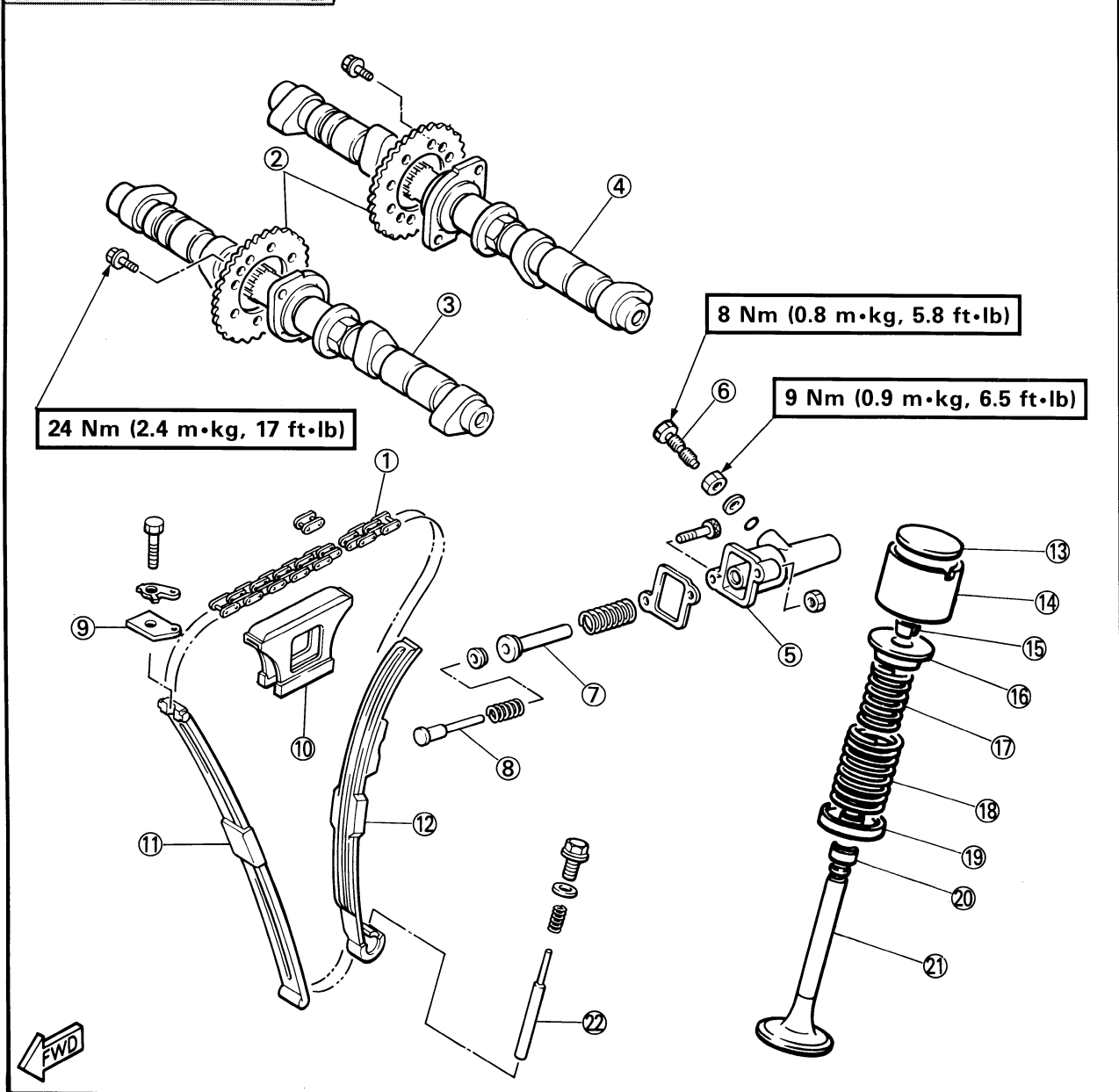



CAMSHAFT

1. Rotate:
 - Crankshaft
 - Counterclockwise

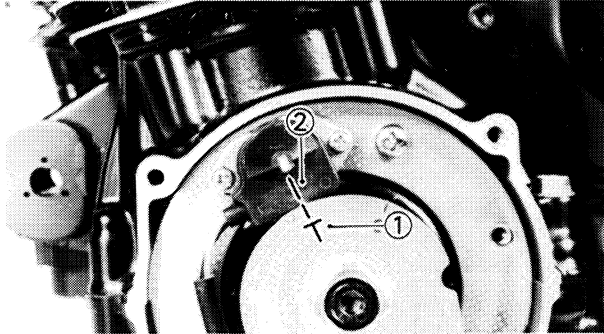

2. Align:
 - “T” mark ①

On the timing plate with the upper pickup coil mark ② when No. 1 piston is at TDC on compression stroke.

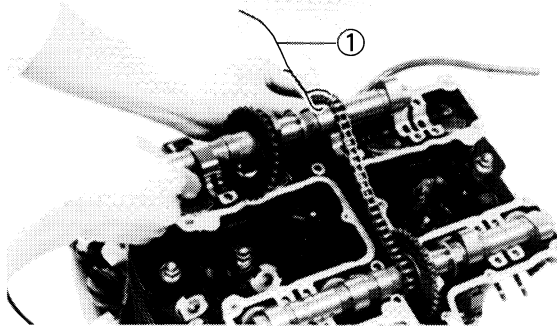

3. Install:
 - Cam chain sprockets (on the camshafts)
 - “I” and “E” camshafts

Apply engine oil to camshaft bearing surfaces before installing camshafts.

4. Remove:
 - Retaining wire ①

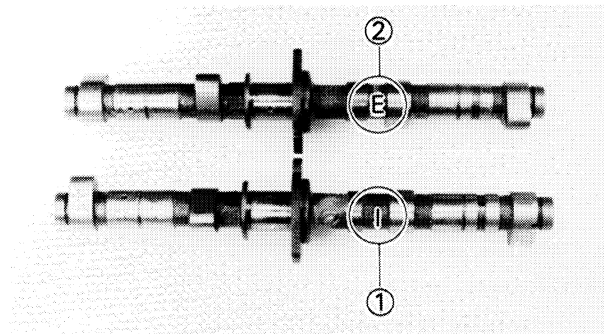

NOTE: _____

- “I” mark ① for intake camshaft
- “E” mark ② for exhaust camshaft

5. Install:
 - Dowel pins
 - Cam caps



10 Nm (1.0 m•kg, 7.2 ft•lb)

NOTE: _____

Do not install No. 3 intake (I-3) and No. 3 exhaust (E-3) cam caps at in this stage.

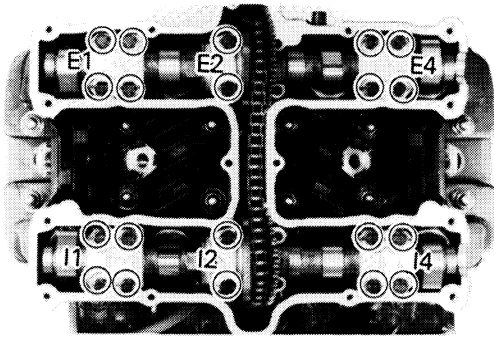
**CAUTION:**

The cam caps must be tightened evenly or damage to the cylinder head, cam caps and cam will result. The spaces between the caps and cylinder head should be equal.

Cam Chain

1. Rotate:
 - Exhaust camshaft
2. Align:
 - Exhaust camshaft timing mark
(with the "E-2" cam cap arrow mark)

CAUTION:

Do not rotate the camshaft over 1/2 turn or damage to the piston and valve will result.

3. Position:
 - Cam chain
(onto sprockets)
4. Install:
 - Sprockets
(onto camshafts)
5. Force the exhaust sprocket clockwise (viewing from left side engine) to remove all cam chain slack.
6. Align:
 - Sprocket, hole
(with the exhaust camshaft thread hole)

NOTE:

If the sprocket hole do not align with the camshaft hole, adjust chain links between crankshaft and exhaust camshaft.

7. Install:
 - Exhaust sprocket bolt
(temporarily tighten)

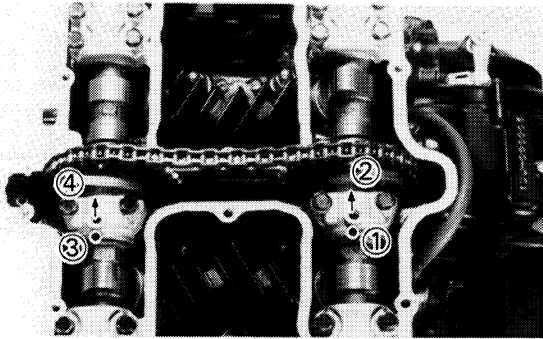

8. Rotate:
 - Intake camshaft
9. Align:
 - Intake camshaft timing mark ①
(with the "I-2" cam cap arrow mark ②)

- ③ Exhaust camshaft timing mark
- ④ "E-2" cam cap arrow mark

CAUTION:

Do not rotate the camshaft over 1/2 turn or damage to the piston and valve will result.

10. Force the intake sprocket clockwise (viewing from left side engine) to remove all cam chain slack.
11. Align:
 - Intake sprocket hole
(with the intake camshaft thread hole)

NOTE:

If the sprocket hole do not align with the camshaft thread hole, adjust chain links between exhaust and intake camshafts.

12. Install:
 - Intake sprocket bolt
(temporarily tighten)

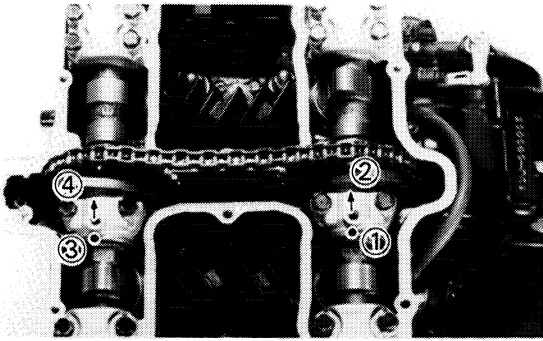
**NOTE:**

- Be sure the camshaft timing marks (① or ③) align with the cam cap arrow mark (② or ④).
- Be sure the "T" mark on the timing plate align with the upper pickup coil mark.

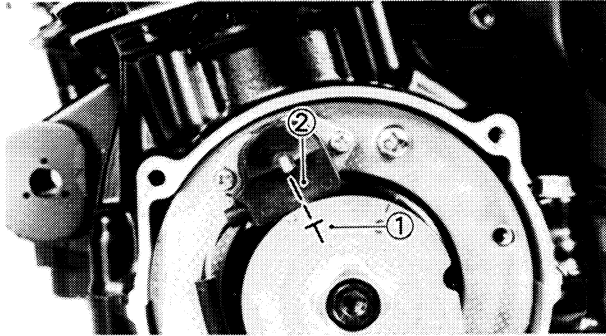

13. Rotate:

- Crankshaft
Counterclockwise

14. Align:

- Timing plate "T" mark ①
(with the upper pickup coil mark ②)

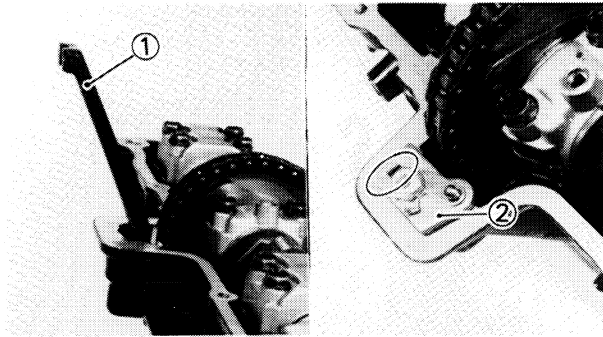

15. Install:

- Exhaust side chain guide ①
- Chain guide stopper ②
- Bolt
- Lock washer

16. Bend the lock washer tab against bolt flat.

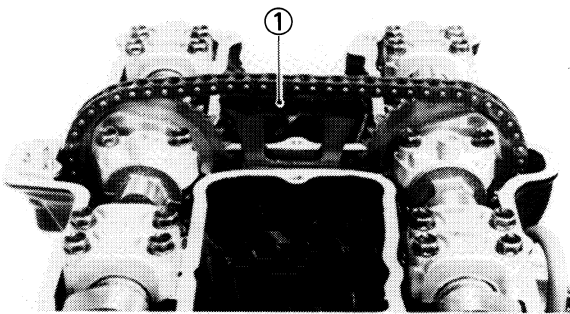

17. Install:

- Upper chain guide ①

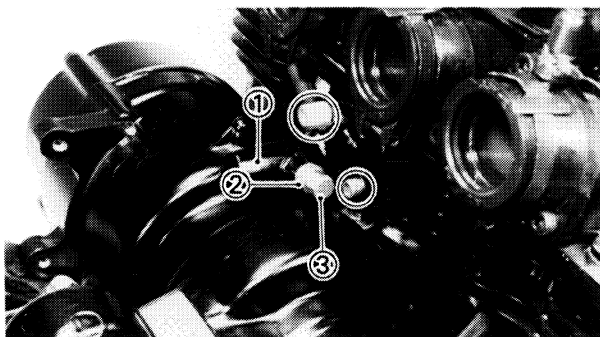

18. Install:

- Cam chain tensioner ①



10 Nm (1.0 m•kg, 7.2 ft•lb)

19. Loosen:

- Locknut ②
- Tensioner lock bolt ③



20. Tighten:
- Tensioner lock bolt
 - Locknut



Bolt:

8 Nm (0.8 m•kg, 5.8 ft•lb)

Locknut:

9 Nm (0.9 m•kg, 6.5 ft•lb)

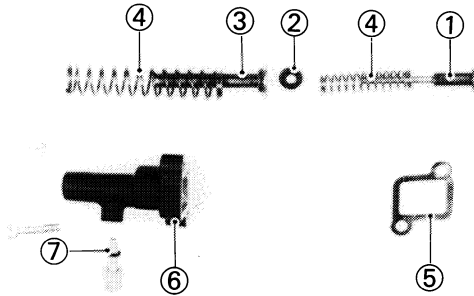

Cam chain tensioner installation steps:

- Install the spring (4), large tensioner rod (3), damper (2), small spring (4), and small tensioner rod (1) into the tensioner body (6).
- Push the tensioner rod assembly into the body.

NOTE:

Face the large rod surface to the lock bolt (7).

- Tighten lock bolt.
- Lock the locknut.

(5) Gasket

21. Rotate:
- Crankshaft
Counterclockwise
22. Install:
- Sprocket bolts (all)



24 Nm (2.4 m•kg, 18 ft•lb)

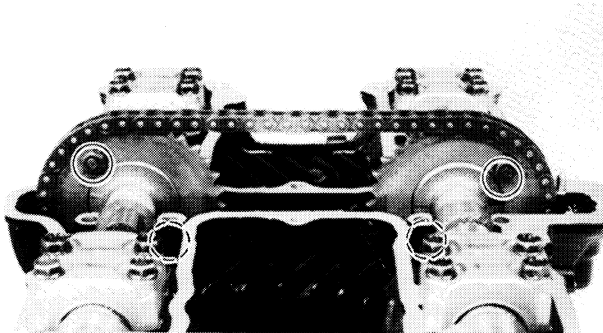



23. Install:

- No. 3 intake cam cap
- No. 3 exhaust cam cap



Bolts (Cam Cap):
10 Nm (1.0 m•kg, 7.2 ft•lb)

24. Install:

- Left crankcase cover



Screw:
10 Nm (1.0 m•kg, 7.2 ft•lb)

25. Install:

- Spark plug ①



17.5 Nm (1.75 m•kg, 12.7 ft•lb)

- Head cover gasket
- Head cover ②



Bolt:
10 Nm (1.0 m•kg, 7.2 ft•lb)

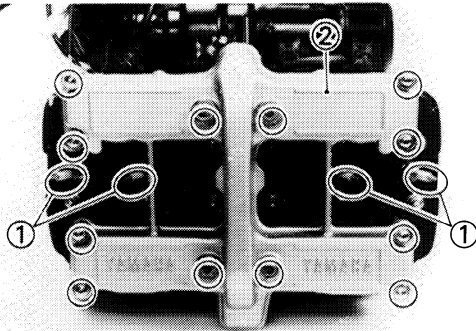

REMounting ENGINE

Reverse the removal procedure. Note the following points.

1. Tighten:

- Engine mounting bolts



Front Upper Bolts ①:
42 Nm (4.2 m•kg, 30 ft•lb)
Front Bracket Bolt ②:
32 Nm (3.2 m•kg, 23 ft•lb)
Front Lower Bolts ③:
42 Nm (4.2 m•kg, 30 ft•lb)
Rear Bolts ④:
90 Nm (9.0 m•kg, 65 ft•lb)

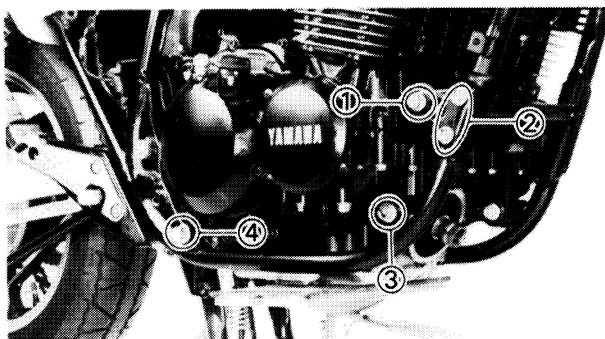

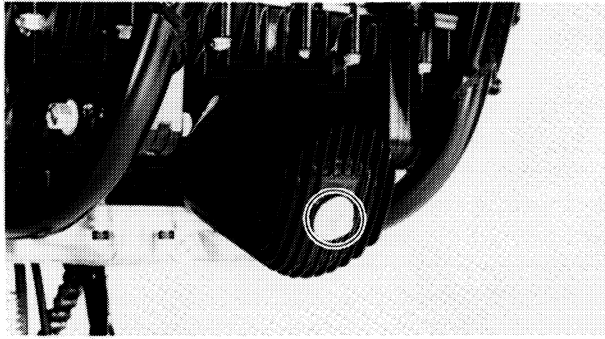

2. Tighten:
•Oil filter bolt

	15 Nm (1.5 m•kg, 11 ft•lb)
---	-----------------------------------

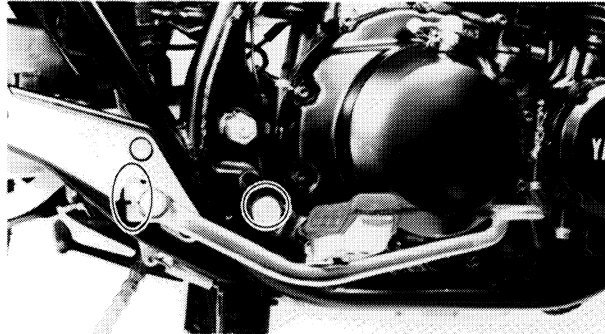

3. Tighten:
•Bolt (Footrest)

	70 Nm (7.0 m•kg, 50 ft•lb)
---	-----------------------------------

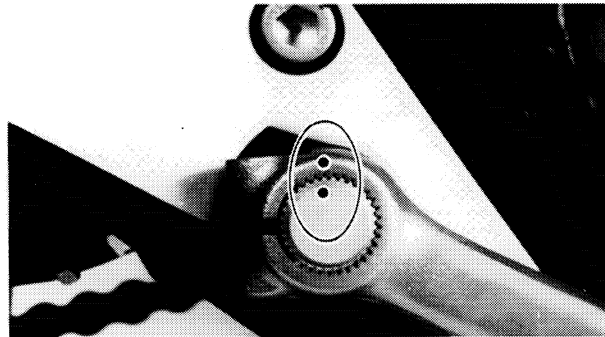

4. Install:
•Brake pedal

NOTE: _____

Align the punch marks on the brake shaft and the pedal.

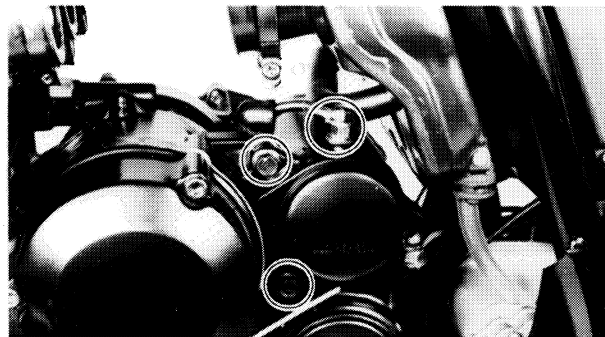

5. Install:
•Starter motor

	Bolt (Starter Motor): 10 Nm (1.0 m•kg, 7.2 ft•lb)
---	--

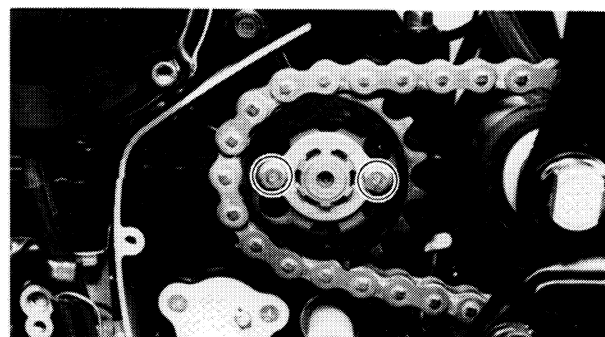

6. Install:
•Drive chain
•Drive sprocket

	Bolts (Drive Sprocket): 10 Nm (1.0 m•kg, 7.2 ft•lb)
---	--

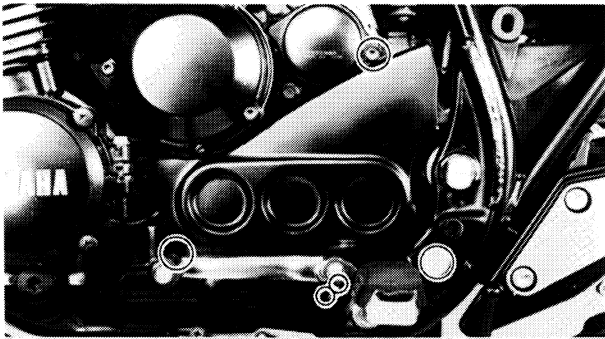

7. Install:
- Drive sprocket cover
 - Change pedal
 - Footrest



Bolt (Change Pedal):
 10 Nm (1.0 m•kg, 7.2 ft•lb)
Bolt (Footrest):
 70 Nm (7.0 m•kg, 50 ft•lb)

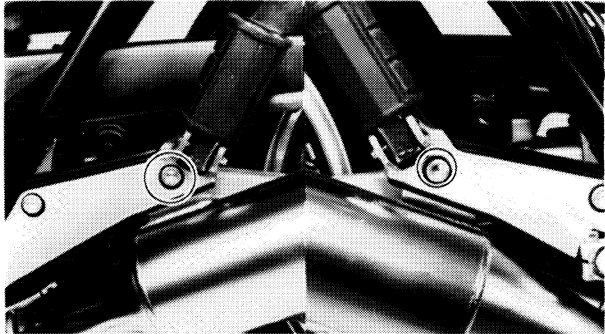

8. Install:
- Mufflers



Bolt:
 25 Nm (2.5 m•kg, 18 ft•lb)
Bolt:
 25 Nm (2.5 m•kg, 18 ft•lb)

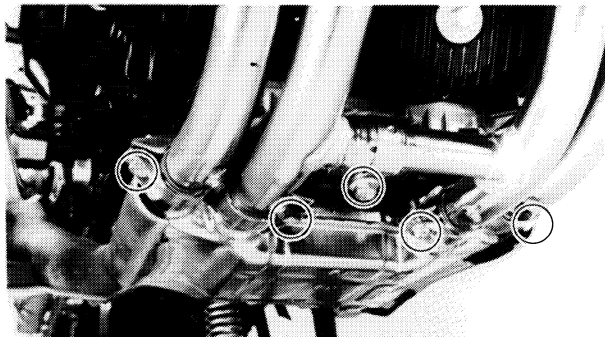

9. Install:
- Exhaust pipes



Nuts (Exhaust Pipe):
 10 Nm (1.0 m•kg, 7.2 ft•lb)
Bolts (Exhaust Pipe Joint):
 20 Nm (2.0 m•kg, 14 ft•lb)

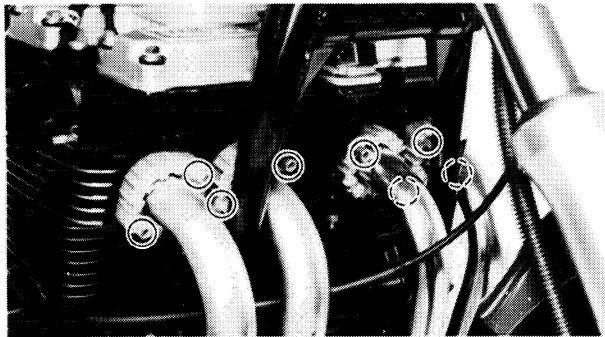

10. Fill:
- Crankcase



Recommended Oil:
 Yamalube 4, SAE 20W40 Type
 SE Motor oil or SAE 10W30
 Type SE Motor oil

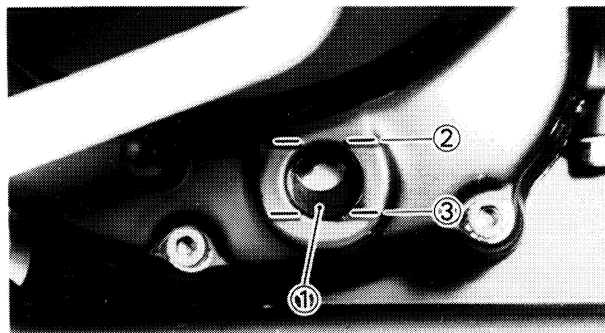

Refer to "CHAPTER 2—ENGINE OIL LEVEL INSPECTION" section.

- ① Level window
- ② Maximum mark
- ③ Minimum mark

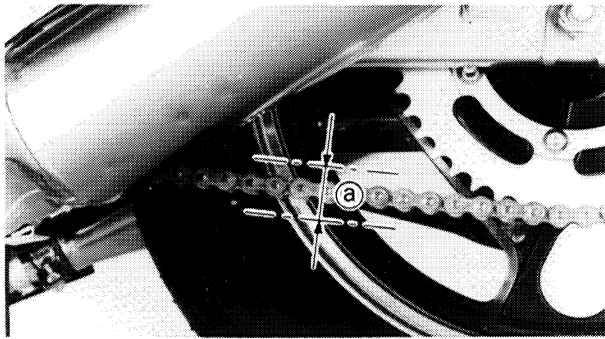

11. Adjust:
• Drive chain slack (a)



Drive Chain Slack:
20 ~ 30 mm (0.8 ~ 1.2 in)

Refer to "CHAPTER 2—DRIVE CHAIN SLACK ADJUSTMENT" section.

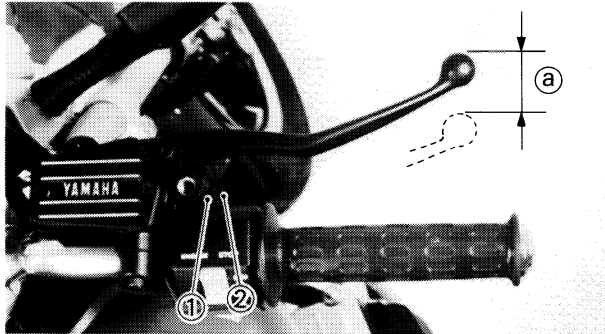

12. Adjust:
• Brake lever free play (a)



Free Play:
2 ~ 5 mm (0.08 ~ 0.20 in)

Refer to "CHAPTER 2—BRAKE LEVER FREE PLAY ADJUSTMENT" section.

- ① Locknut
② Adjuster

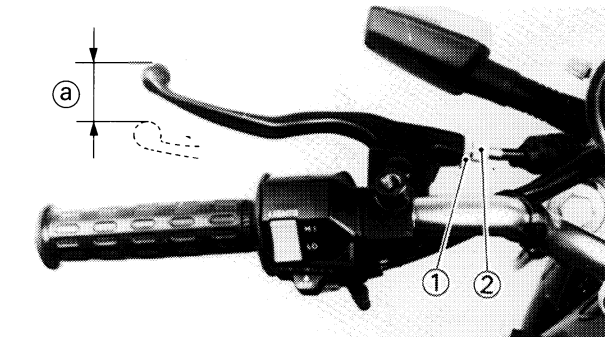

13. Adjust:
• Clutch lever free play (a)



Free Play:
10 ~ 15 mm (0.4 ~ 0.6 in)

Refer to "CHAPTER 2—CLUTCH LEVER FREE PLAY ADJUSTMENT" section.

- ① Locknut
② Adjuster

14. Adjust:
• Cam chain
Refer to "CHAPTER 2—CAM CHAIN ADJUSTMENT" section.

15. Adjust:
• Idle speed



1,250 ~ 1,350 r/min

Refer to "CHAPTER 2—IDLE SPEED ADJUSTMENT" section.



MEMO



CHAPTER 4 CARBURETION

CARBURETOR	4-1
SECTION VIEW	4-2
REMOVAL	4-3
DISASSEMBLY	4-5
INSPECTION	4-7
ASSEMBLY	4-8
INSTALLATION	4-9
ADJUSTMENT	4-10
AIR CLEANER AND CRANKCASE VENTILATION SYSTEM	4-13



CARBURETION

CARBURETOR

- ① Jet needle set
- ② Throttle valve
- ③ Main nozzle
- ④ Pilot air jet
- ⑤ Starter plunger set
- ⑥ Valve seat set
- ⑦ Main jet
- ⑧ Pilot jet
- ⑨ Float
- ⑩ Drain screw
- ⑪ O-ring
- ⑫ Starter lever
- ⑬ Synchronizing screw
- ⑭ Throttle stop screw

SPECIFICATIONS	
MAIN JET	#97.5
MAIN AIR JET	#140
PILOT JET	#30
PILOT AIR JET	#135
JET NEEDLE	
#1 AND #4	4CHP2
#2 AND #3	4CHP4
PILOT SCREW	PRESET
THROTTLE VALVE	#140
ENGINE IDLE SPEED	1,250 ~ 1,350 r/min
FUEL LEVEL	2 ± 0.5 mm (0.08 ± 0.02 in)
FLOAT HEIGHT	20 ± 1.0 mm (0.8 ± 0.04 in)

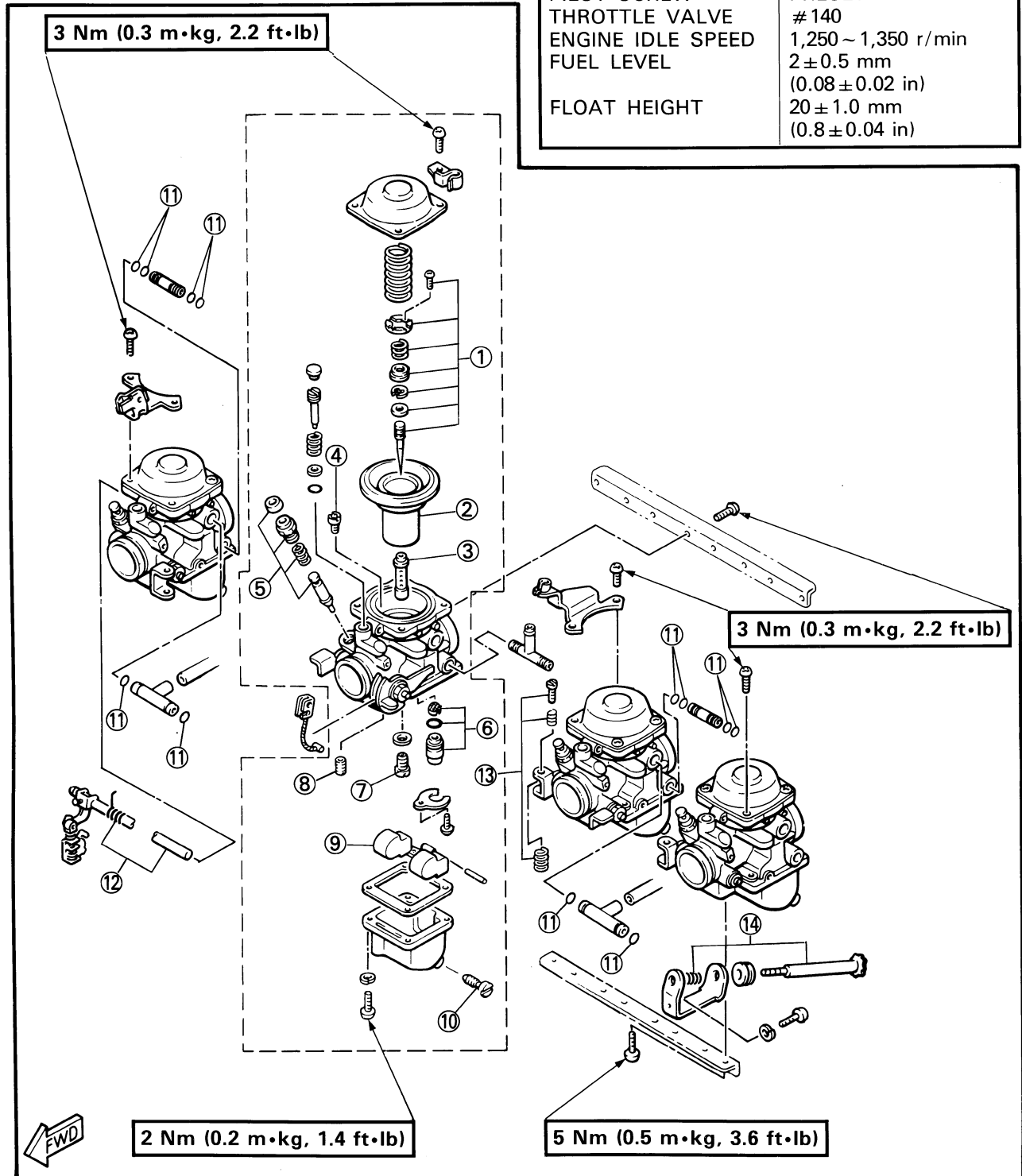



SECTION VIEW

- ① Throttle valve
- ② Pilot air jet
- ③ Jet needle
- ④ Pilot jet
- ⑤ Main jet
- ⑥ Main nozzle
- ⑦ Valve seat
- ⑧ Float
- ⑨ Starter plunger
- ⑩ Starter jet

- A Main metering system
- B Float system
- C Starter system

- ← Air
- ← Fuel
- ← Mixture

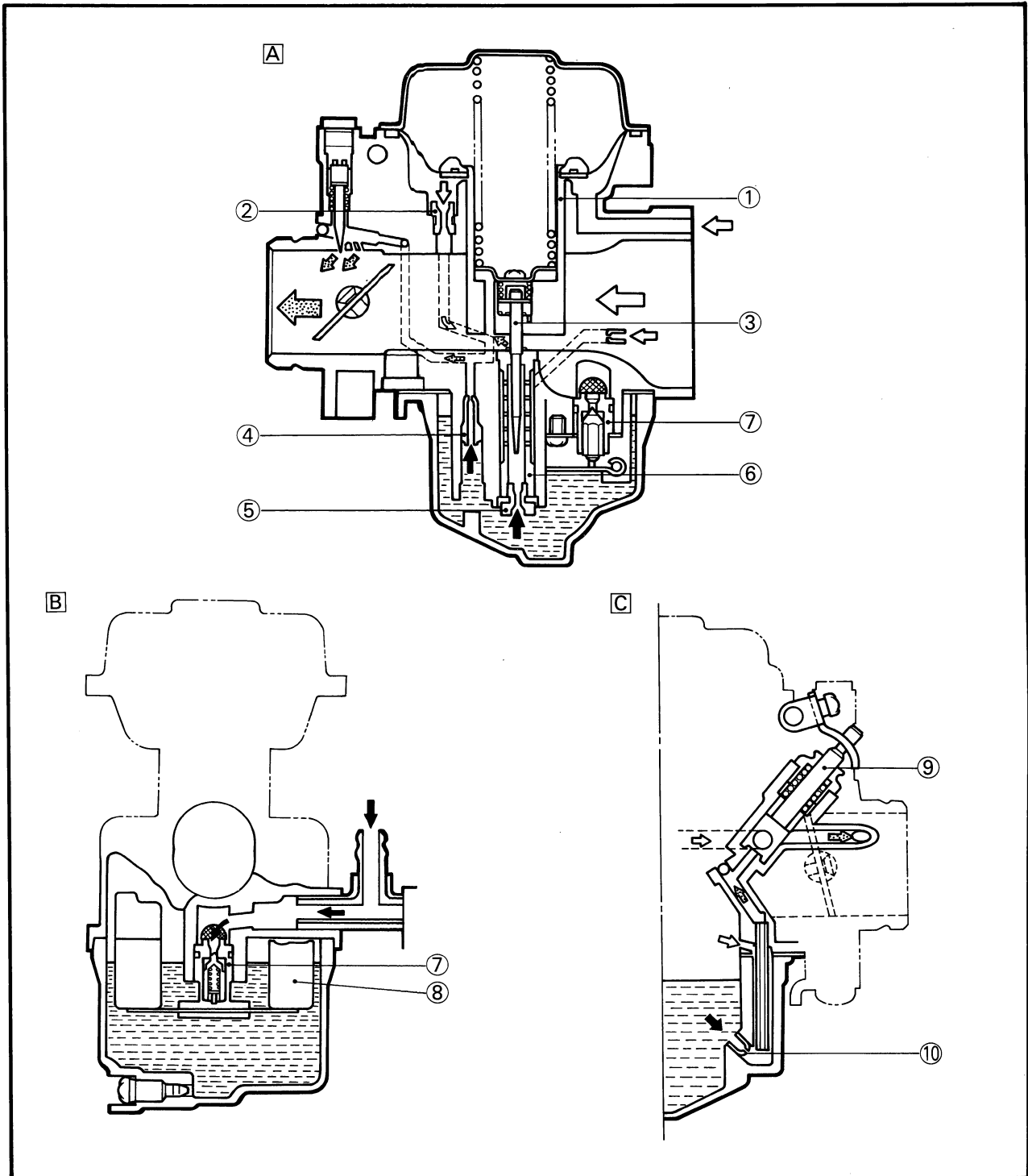

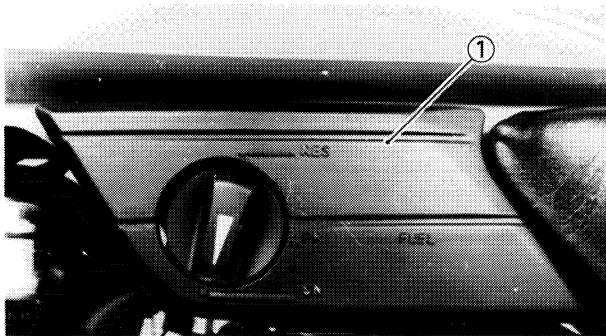

REMOVAL

1. Turn the fuel cock to "ON" position.

2. Remove:

- Seat
- Cover (Fuel cock) ①

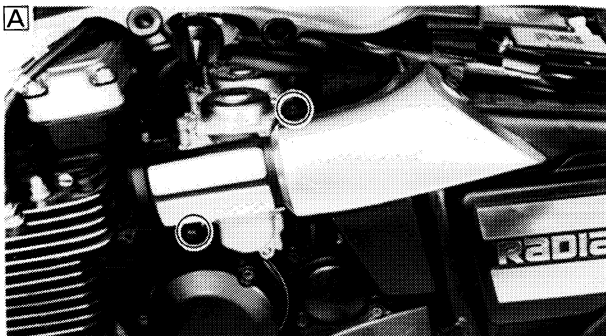

3. Remove:

- Cover (Carburetor)

- A** Left side
- B** Right side

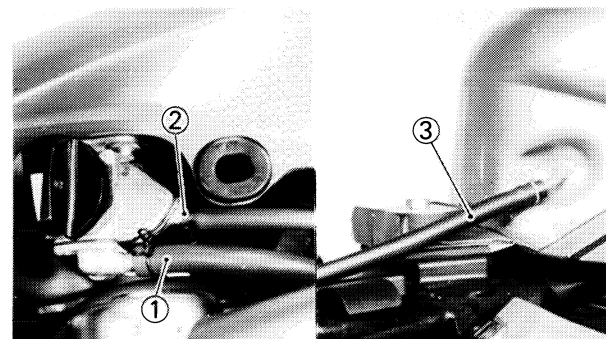
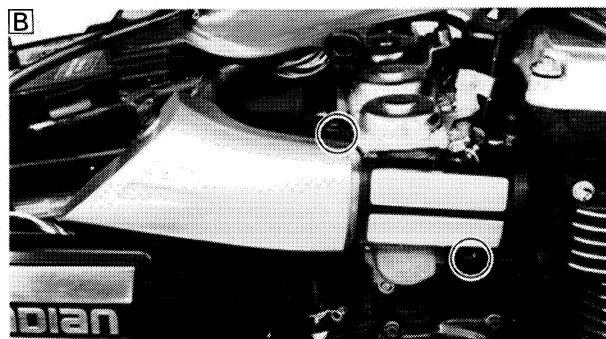

4. Disconnect:

- Fuel pipe ①
- Vacuum pipe ②
- Fuel tank breather pipe ③

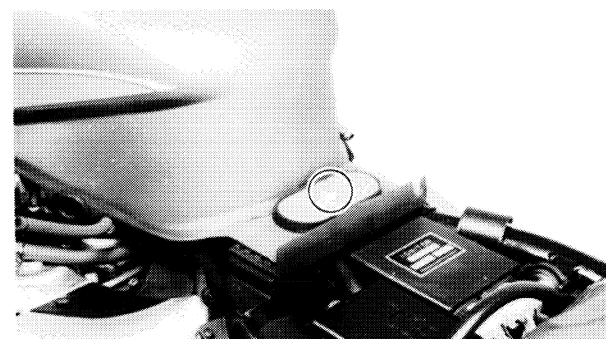

5. Remove:

- Fuel tank

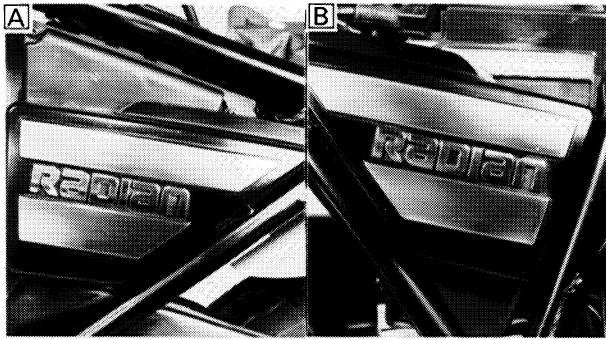

6. Remove:
- Side cover

- A Left side
- B Right side

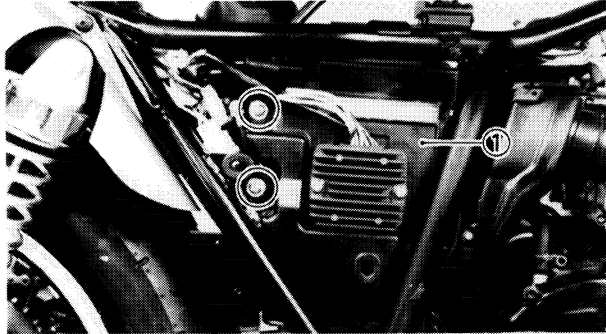

7. Remove:
- Battery case cover ①
 - Battery

CAUTION:

Disconnect the negative lead first, and then disconnect the positive lead.

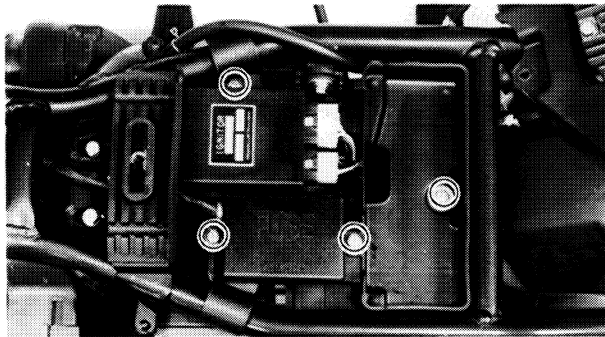

8. Remove:
- Screws (Fuse box)
 - Ignitor unit

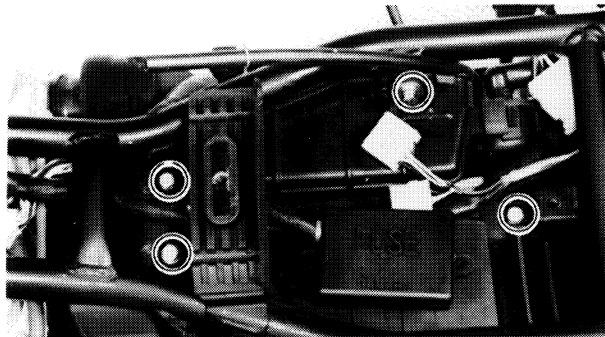

9. Remove:
- Bolts (Battery case)
 - Bolts (Air cleaner case)

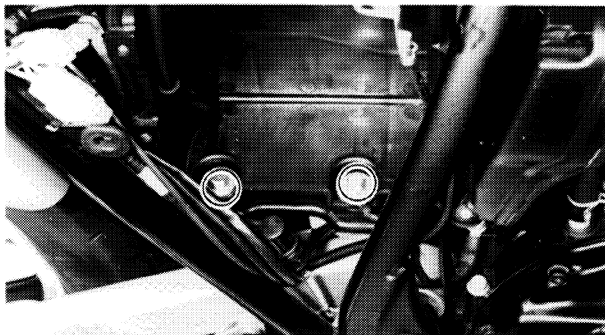

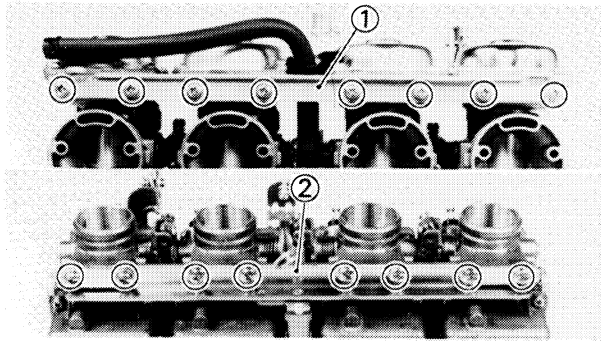

2. Remove:
- Upper bracket ①
 - Lower bracket ②

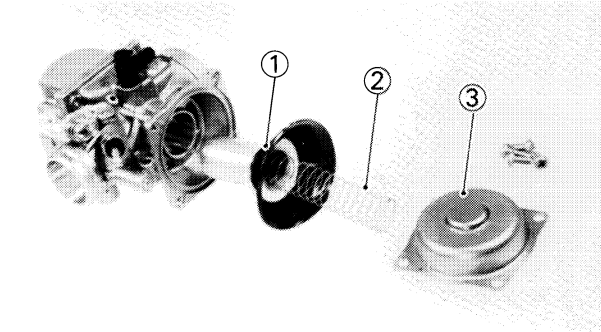

3. Remove:
- Vacuum chamber cover ①
 - Spring ②
 - Throttle valve assembly ③

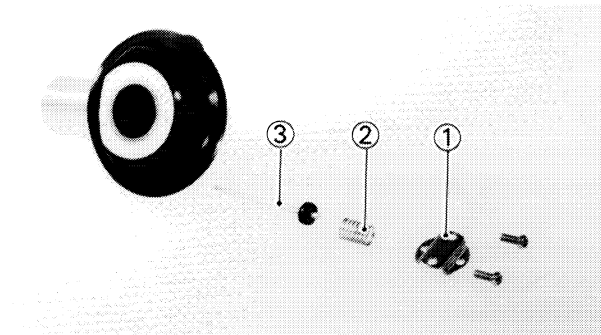

4. Remove:
- Jet needle cover ①
 - Spring ②
 - Jet needle ③

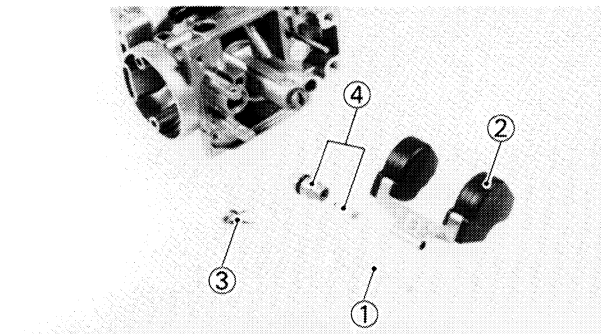

5. Remove:
- Float chamber cover ①
 - Gasket ②
 - Float pin ③
 - Float ④
 - Valve seat plate ⑤
 - Valve seat assembly ⑥

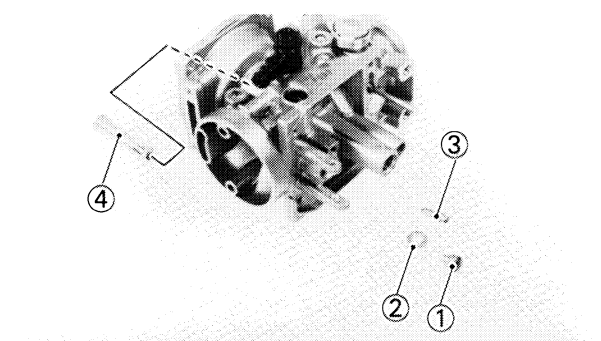

6. Remove:
- Main jet ①
 - Washer ②
 - Pilot jet ③
 - Main nozzle ④

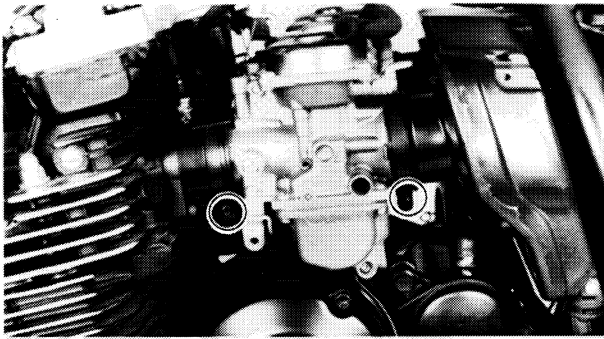

10. Loosen:
- Screws (Carburetor joints)

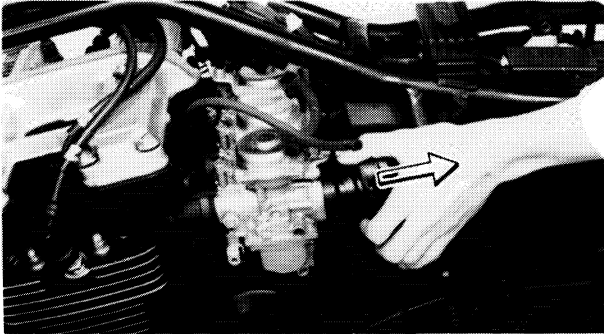

11. Slide the air cleaner case and the battery case backward.

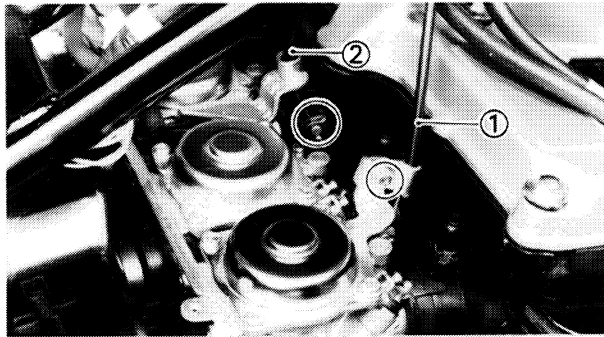

12. Remove:
- Starter cable ①
 - Throttle cable ②
 - Air bent hoses
 - Carburetor assembly

DISASSEMBLY

NOTE: _____

The following parts can be cleaned and inspected without carburetor separation.

- Throttle valve
- Starter plunger
- Float chamber components

1. Remove:
- Starter lever shaft

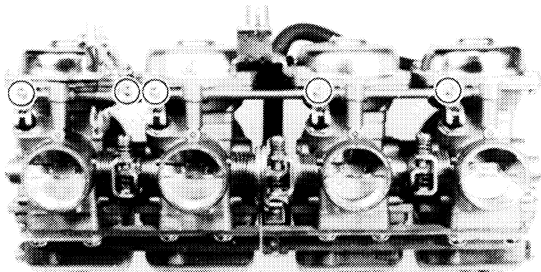

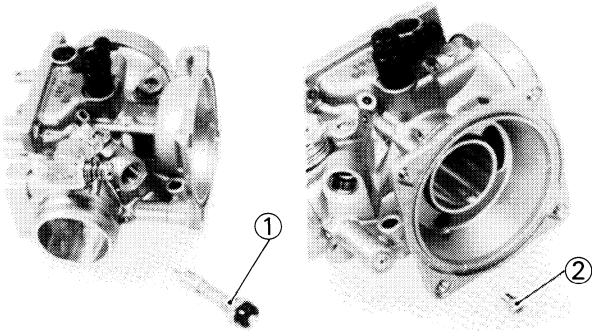

7. Remove:
- Starter plunger ①
 - Pilot air jet ②

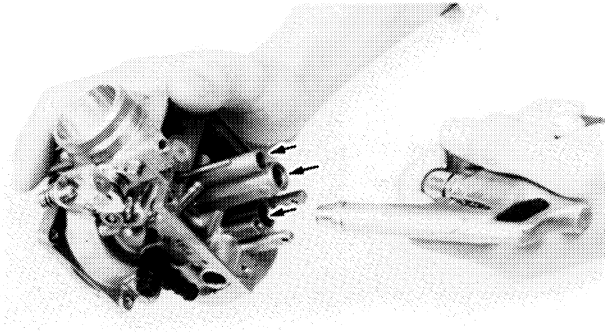

INSPECTION

1. Inspect:
- Carburetor body
 - Fuel passage
- Contamination → Clean as indicated.

Carburetor cleaning steps:

- Wash carburetor in petroleum based solvent. (Do not use any caustic carburetor cleaning solution.)
- Blow out all passages and jets with compressed air.

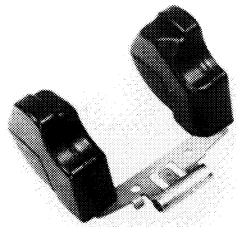

2. Inspect:
- Floats
- Damage → Replace.

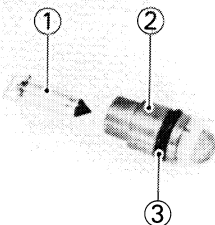

3. Inspect:
- Float needle valve ①
 - Seat ②
 - O-ring ③
- Damage/Wear/Contamination → Replace as a set.

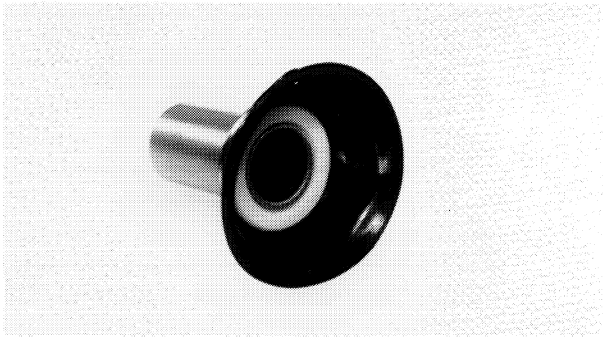

4. Inspect:
- Throttle valve
Scratches → Replace.
 - Rubber diaphragm
Tears → Replace.

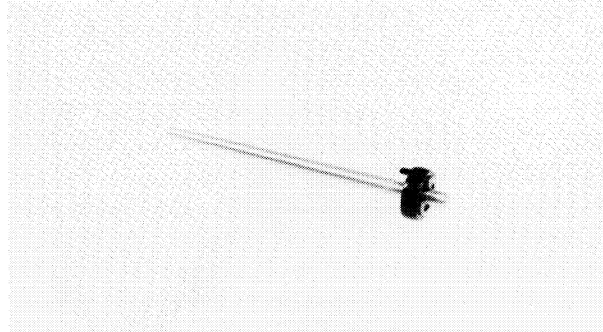

5. Inspect:
- Jet needle
Bends/Wear → Replace.

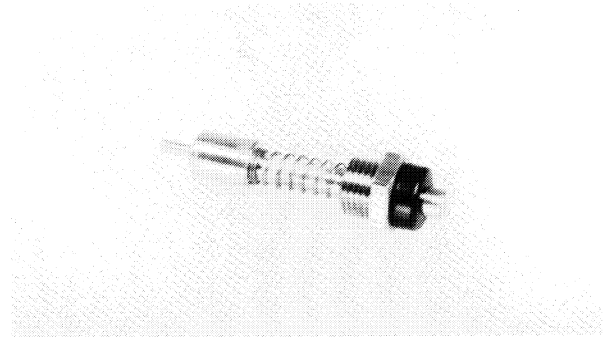

6. Inspect:
- Starter plunger
Wear/Damage → Replace.

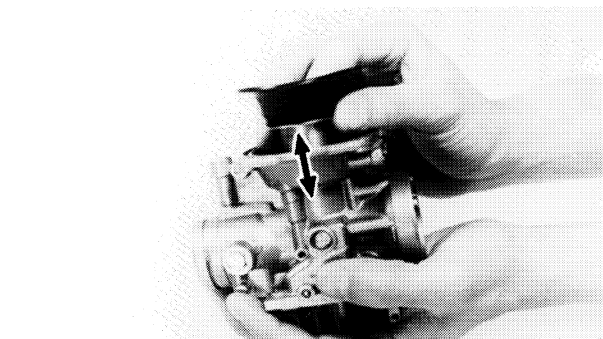

7. Check:
- Free movement
Insert the throttle valve into the carburetor body, and check for free movement.
Stick → Replace.

4

ASSEMBLY

To assemble the carburetor, reverse the disassembly procedures. Note the following points.

CAUTION:

- Before reassembling, wash all parts in clean gasoline.
- Always use a new gasket.

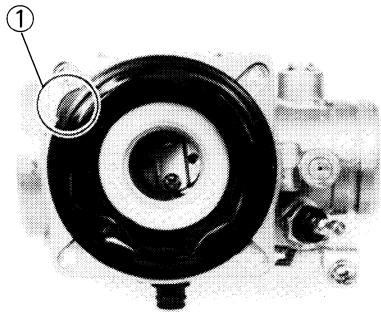

1. Install:
 - Throttle valve

NOTE:

Note position of tab ① on diaphragm. This tab must be placed in the cavity of the carburetor body during reassembly.

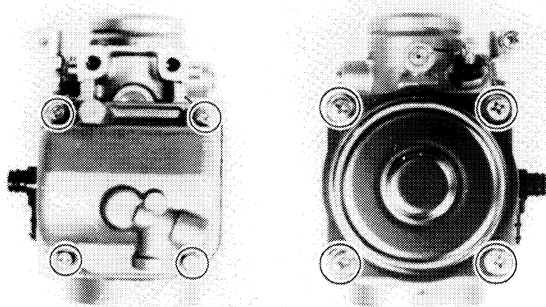

2. Install:
 - Float chamber cover
 - Vacuum chamber cover

	Screw (Float Chamber Cover):
	2 Nm (0.2 m•kg, 1.4 ft•lb)
	Screw (Vacuum Chamber Cover):
	3 Nm (0.3 m•kg, 2.2 ft•lb)

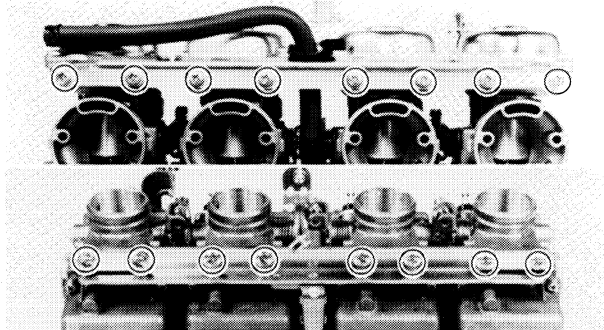

3. Install:
 - Upper bracket
 - Lower bracket

	Screw (Upper Bracket):
	3 Nm (0.3 m•kg, 2.2 ft•lb)
	Screw (Lower Bracket):
	5 Nm (0.5 m•kg, 3.6 ft•lb)

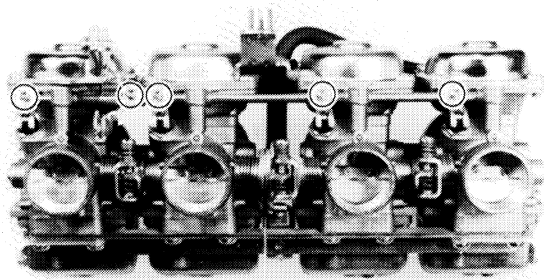

4. Install:
 - Starter lever shaft

	Screw (Starter Lever Shaft):
	3 Nm (0.3 m•kg, 2.2 ft•lb)
	Apply LOCTITE®.

INSTALLATION

1. Install:
 - Carburetor assembly

Reserve the removal procedure.

**ADJUSTMENT****NOTE:** _____

Before adjusting the fuel level, the float height should be adjusted.

CAUTION: _____

The pilot screw settings are adjusted for maximum performance at the factory. Any attempt to change these settings will decrease engine performance.

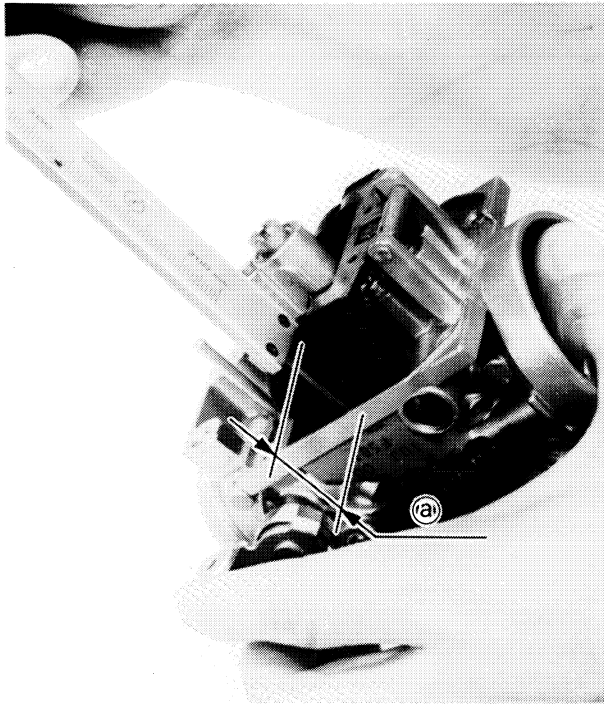
**Float Height Adjustment**

1. Measure:

- Float height (a)

Out of specification → Adjust it by the following adjustment steps.

**Float Height:**

20.0 ± 1.0 mm (0.8 ± 0.04 in)

Float height measurement steps:

- Hold the carburetor in an upside down position.
- Incline the carburetor at $60 \sim 70^\circ$ (so that the end of the float valve does not hang down as a result of float weight).
- Measure the distance from the mating surface of the float chamber (gasket removed) to the top of the float.

NOTE: _____

The float should be just resting on, but not depressing, the spring loaded inlet needle.

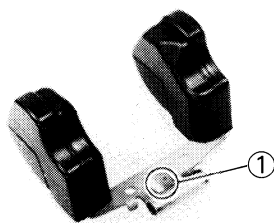

2. Adjust:
- Float height

Float height adjustment steps:

- Remove the float, valve seat and the needle valve.
- Inspect the valve seat and the needle valve. If either is worn, replace as a set.
- If both are fine, adjust the float height by bending the float tang ①.
- Recheck the float height.

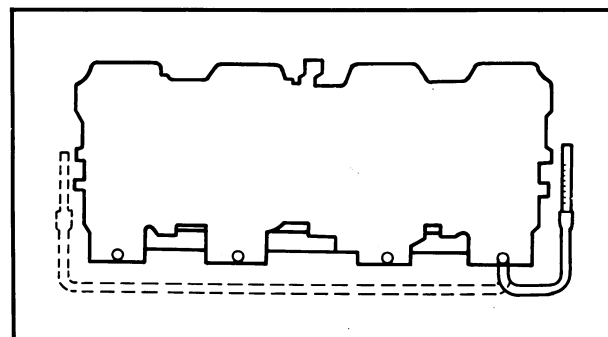
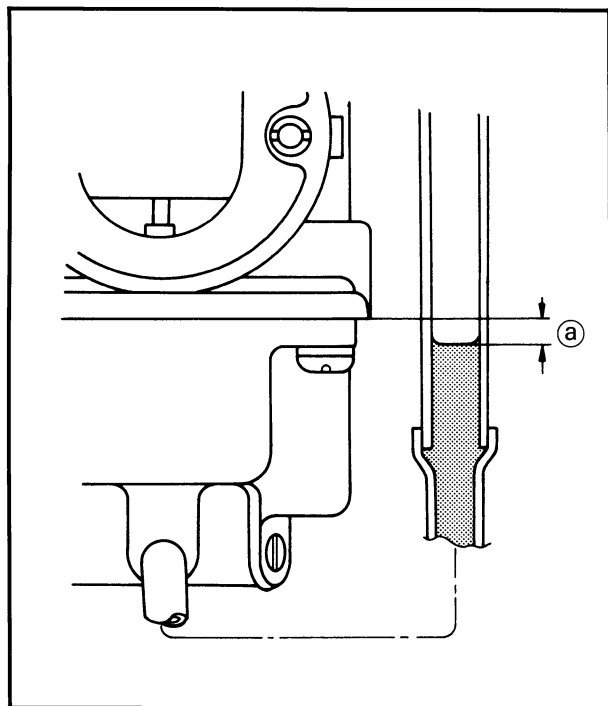

Fuel Level Adjustment

1. Measure:

- Fuel level ①
- Out of specification → Adjust it by the following adjustment steps.



Fuel Level ①:

$2.0 \pm 0.5 \text{ mm}$ ($0.08 \pm 0.02 \text{ in}$)
Below the Carburetor Body
Edge.

Fuel level measurement steps:

- Place the motorcycle on the level place.
- Install the Fuel Level Gauge Adapter (YM-01329) to the drain hole of the carburetor.
- Connect the Fuel Level Gauge (YM-01312) to the Adapter.
- Place the Gauge vertically next to the center of the mating line of the mixing body and float chamber cover.
- Loosen the drain screw.
- Warm up the engine, then shut it off after a few minutes.
- Measure the fuel level. It should be within the specified range.

NOTE:

Fuel level readings of both side of carburetor line should be equal.

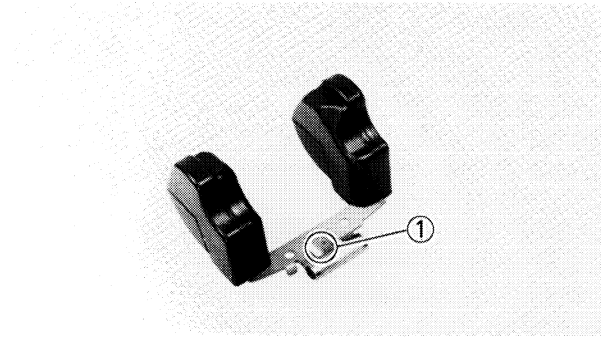

2. Adjust:
- Fuel level

Fuel level adjustment steps:

- Remove the carburetor assembly. Refer to "REMOVAL" section.
- Remove the float, valve seat and the needle valve.
- Inspect the valve seat and the needle valve. If either is worn, replace as a set.
- If both are fine, adjust the float height by bending the float tang ①.
- Recheck the fuel level.

**AIR CLEANER AND CRANKCASE VENTILATION SYSTEM**

Refer to "CHAPTER 2—AIR CLEANER CLEANING" for air cleaner maintenance.

- ① Air cleaner
- ② Carburetor
- ③ Fresh air
- ④ Blow by gas

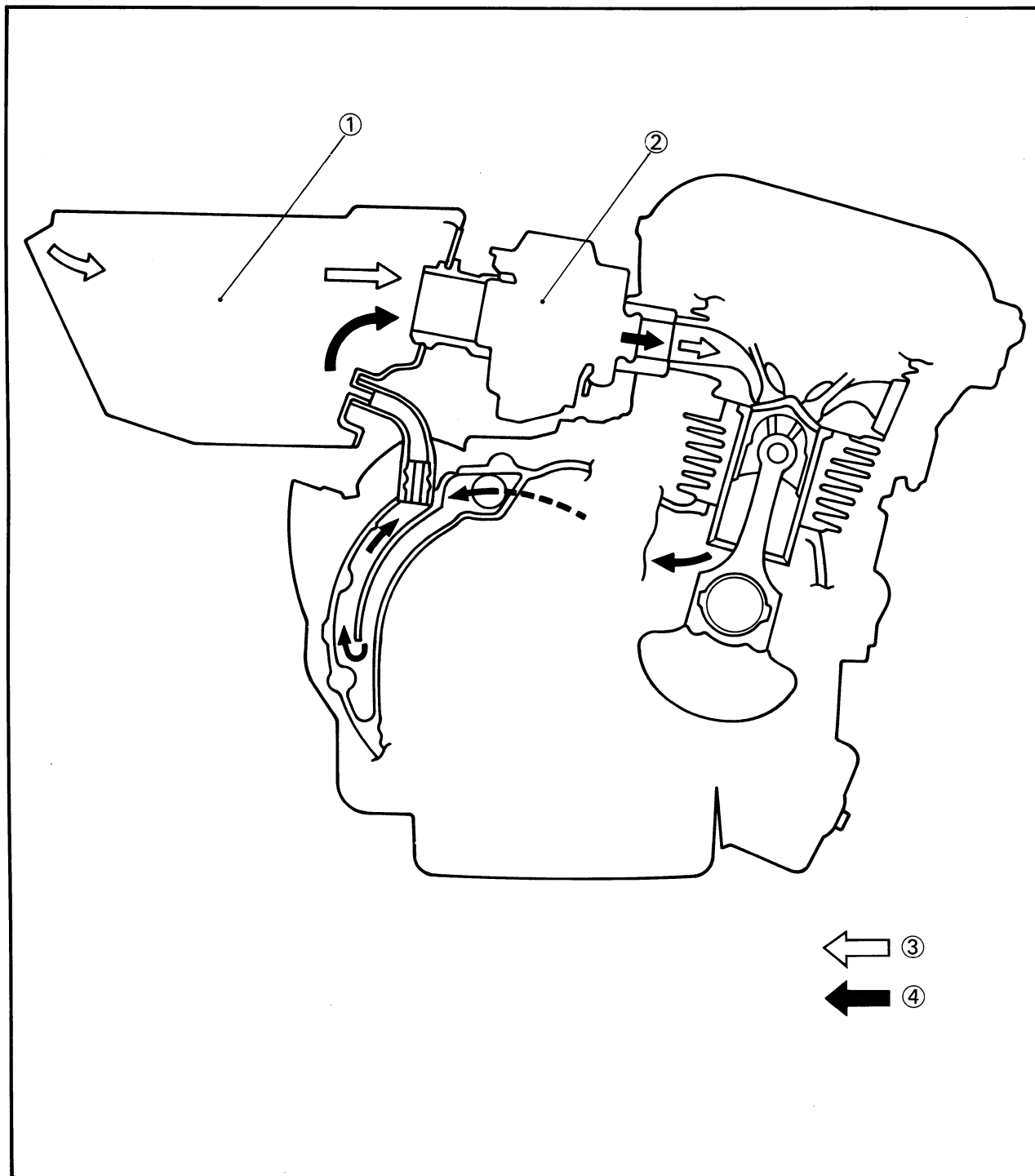



CHAPTER 5 CHASSIS

FRONT WHEEL	5-1
REMOVAL	5-2
INSPECTION	5-2
INSTALLATION	5-4
 REAR WHEEL AND BRAKE	 5-7
REMOVAL	5-8
INSPECTION	5-9
ASSEMBLY (BRAKE SHOE PLATE)	5-10
INSTALLATION	5-11
 FRONT BRAKE	 5-13
CALIPER PAD REPLACEMENT	5-15
CALIPER DISASSEMBLY	5-16
INSPECTION	5-17
INSTALLATION	5-17
MASTER CYLINDER DISASSEMBLY	5-18
INSPECTION	5-19
INSTALLATION	5-20
AIR BLEEDING	5-21
 FRONT FORK	 5-23
REMOVAL	5-24
DISASSEMBLY	5-25
INSPECTION	5-26
REASSEMBLY	5-27
INSTALLATION	5-29
 STEERING HEAD	 5-31
REMOVAL	5-32
INSPECTION	5-35
INSTALLATION	5-36
 REAR SHOCK ABSORBER	 5-39
REMOVAL	5-40
INSPECTION	5-40
INSTALLATION	5-40
 SWINGARM	 5-41
REMOVAL	5-42
INSPECTION	5-43
ADJUSTMENT	5-44
INSTALLATION	5-45
 DRIVE CHAIN AND SPROCKETS	 5-47
REMOVAL	5-47
INSPECTION	5-47
ASSEMBLY	5-48



CHASSIS

FRONT WHEEL

- ① Front axle
- ② Collar
- ③ Oil seal
- ④ Bearing
- ⑤ Spacer
- ⑥ Flange spacer
- ⑦ Bearing
- ⑧ Meter clutch
- ⑨ Clutch retainer
- ⑩ Oil seal
- ⑪ Gear unit assembly
- ⑫ Front wheel

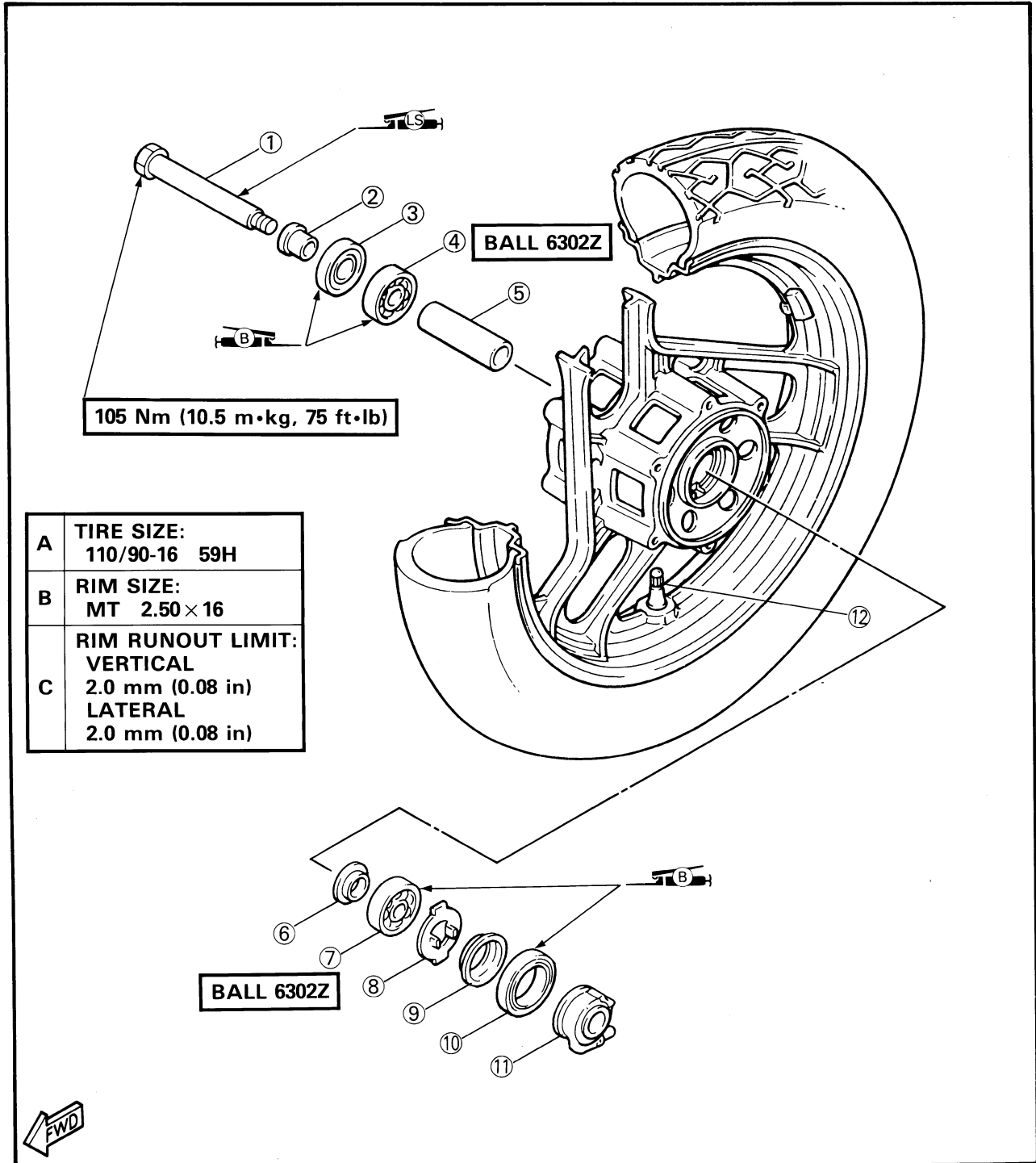

REMOVAL

1. Place the motorcycle on its centerstand.

WARNING: _____

Support the motorcycle securely so there is no danger of it falling over.

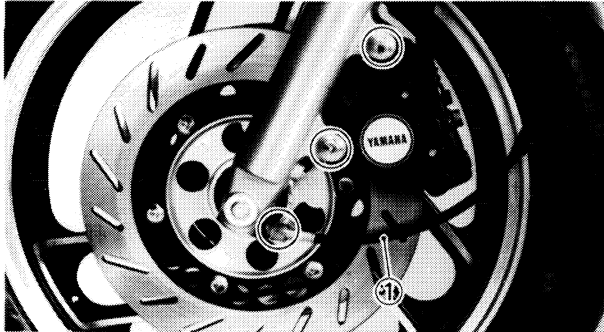

2. Remove:
 - Speedometer cable ①
 - Brake caliper (Left and right)

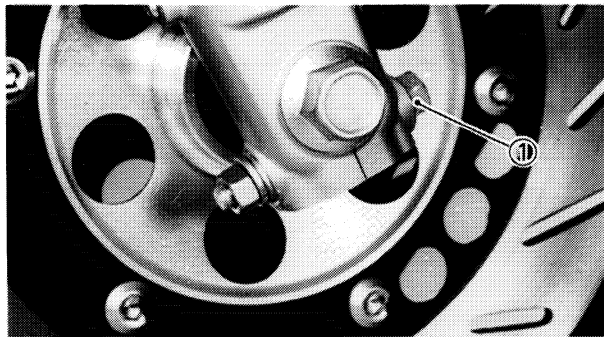

3. Loosen:
 - Pinch bolt ①
4. Remove:
 - Axle
 - Front wheel

NOTE: _____

Do not depress the brake lever when the wheel is off the motorcycle otherwise the brake pads will be forced shut.

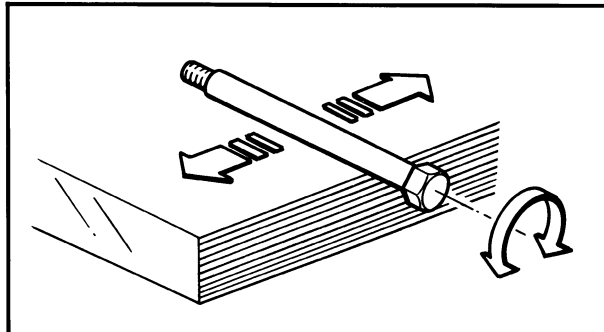
**INSPECTION**

1. Eliminate any corrosion from parts.
2. Inspect:
 - Front axle

Roll the axle on a flat surface.
Bends → Replace.

WARNING: _____

Do not attempt to straighten a bent axle.

3. Measure:
 - Wheel runout

Out of specification → Check the wheel and the bearing play.

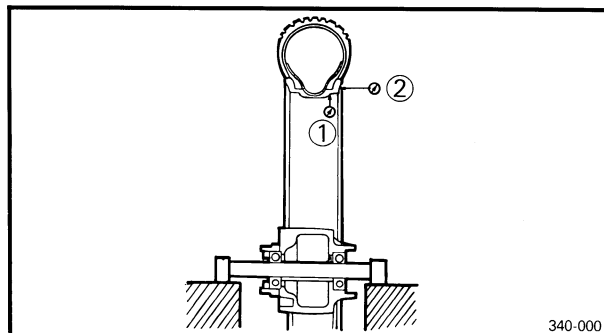

340-000

**Rim Runout Limits:**

Radial ①: 2.0 mm (0.08 in)

Lateral ②: 2.0 mm (0.08 in)



4. Inspect:

- Wheel
Cracks/Bends/Warpage→Replace.

5. Check:

- Wheel bearings
Bearings allow play in the wheel hub or wheel turns roughly→Replace.

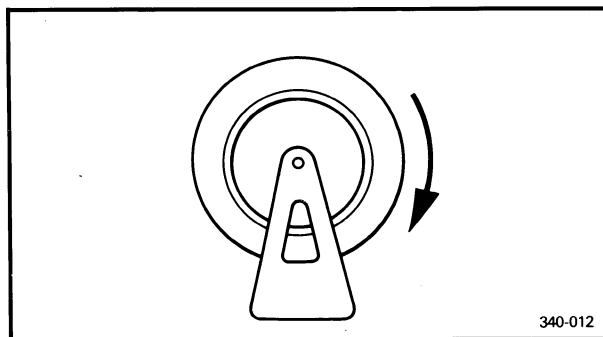
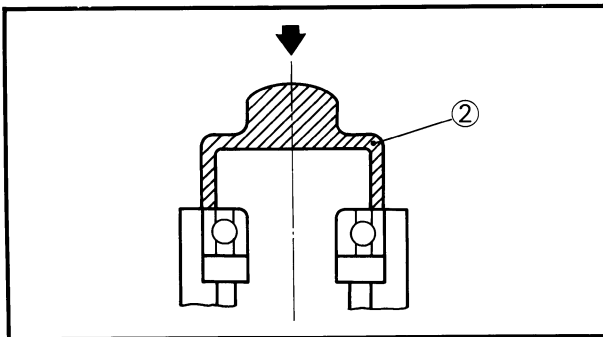
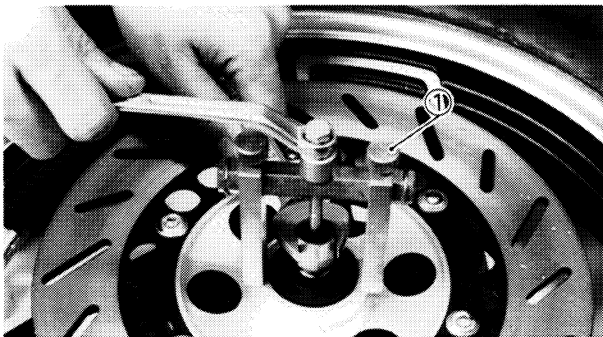

340-012

Wheel bearing replacement steps:

- Clean the out side of the wheel hub.
- Remove the bearing using a general bearing puller ①.
- Install the new bearing.

NOTE:

Use a socket ② that matches the outside diameter of the race of the bearing.

CAUTION:

Do not strike the inner race of balls of the bearing. Contact should be made only with the outer race.

6. Check:

- Wheel balance
Wheel is not statically balanced if it comes to rest at the same point after several light rotations.
Out of balance→Install appropriate balance weight at lightest point (on top).

**NOTE:**

- Balance wheel with brake disc installed.

WARNING:

- After mounting a tire, ride conservatively to allow proper tire to rim seating. Failure to do so may cause an accident resulting in motorcycle damage and possible operator injury.
- After a tire repair or replacement, be sure to torque tighten the valve stem locknut ① to specification.

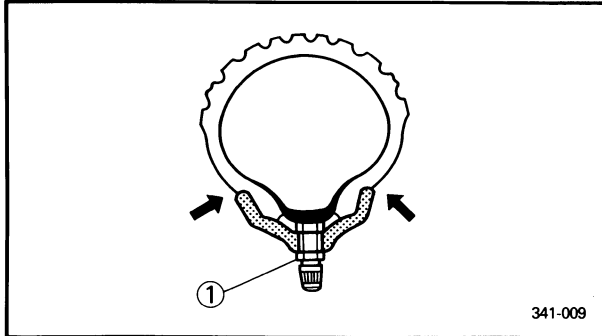

341-009

**Valve-Stem Locknut:****1.5 Nm (0.15 m•kg, 1.1 ft•lb)****INSTALLATION**

When installing the front wheel, reverse the removal procedure. Note the following points.

1. Apply:

- Lithium base grease
Lightly grease to the oil seal and gear unit.

2. Install:

- Gear unit assembly

NOTE:

Make sure the projections inside the gear unit are meshed with the flats in the wheel hub.

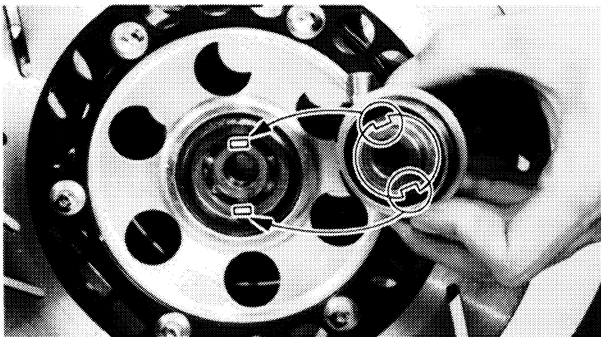

3. Install:

- Front wheel assembly

NOTE:

Be sure the boss on the outer fork tube correctly engages with the locating slot on the gear unit assembly.

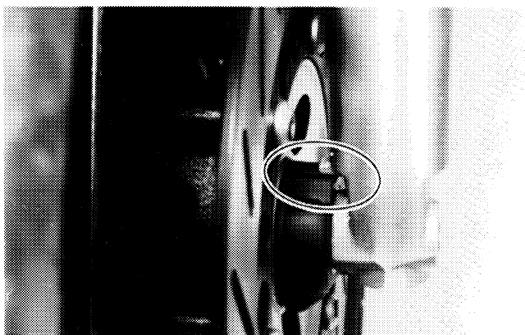

**4. Tighten:**

- Axle nut

**105 Nm (10.5 m•kg, 75 ft•lb)**

- Bolts (Brake caliper)

**35 Nm (3.5 m•kg, 25 ft•lb)**

- Pinch bolt

**20 Nm (2.0 m•kg, 14 ft•lb)**

FRONT WHEEL

CHAS



MEMO



REAR WHEEL AND BRAKE

- ① Rear axle
- ② Collar
- ③ Brake shoe plate
- ④ Brake shoes
- ⑤ Bearing
- ⑥ Flange spacer
- ⑦ Collar
- ⑧ Rear wheel
- ⑨ Bearing
- ⑩ Hub
- ⑪ Drive chain
- ⑫ Driven sprocket
- ⑬ Collar
- ⑭ Bearing
- ⑮ Oil seal
- ⑯ Collar

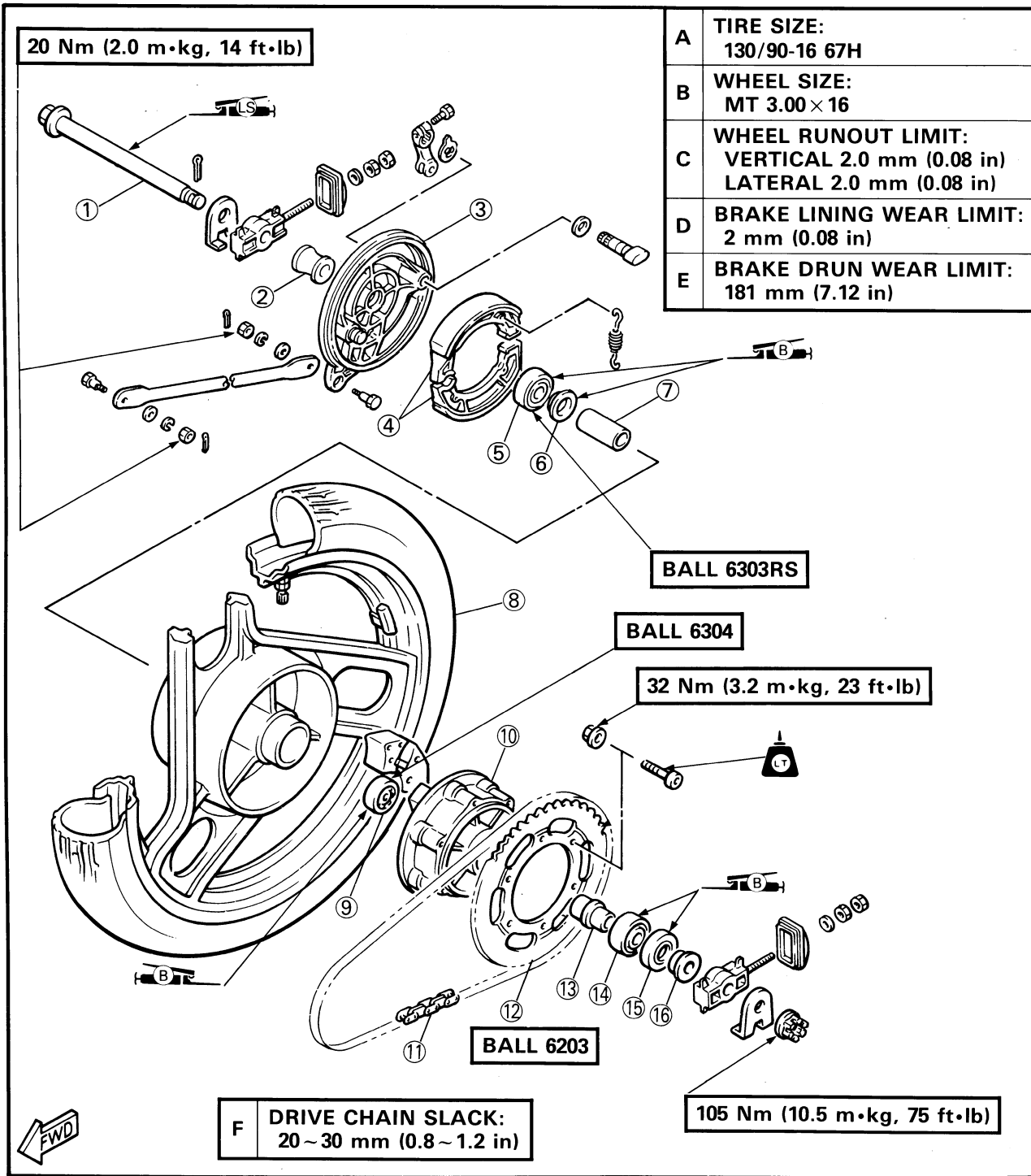



REMOVAL

1. Place the motorcycle on its centerstand.

WARNING: _____

Support the motorcycle securely so there is no danger of it falling over.

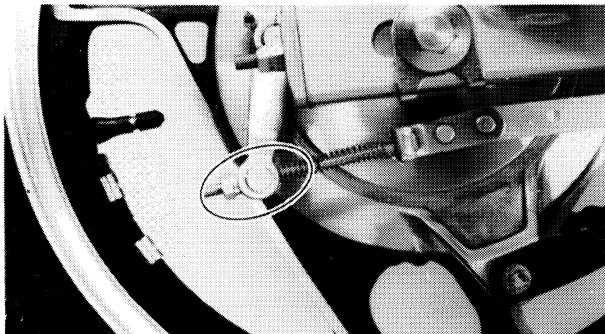

2. Remove:
 - Adjuster
 - Spring
 - Pin

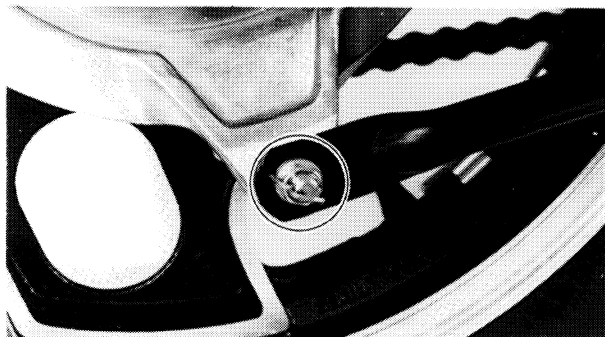

3. Remove:
 - Cotter pin
 - Nut
 - Spring washer
 - Plain washer
 - Bolt

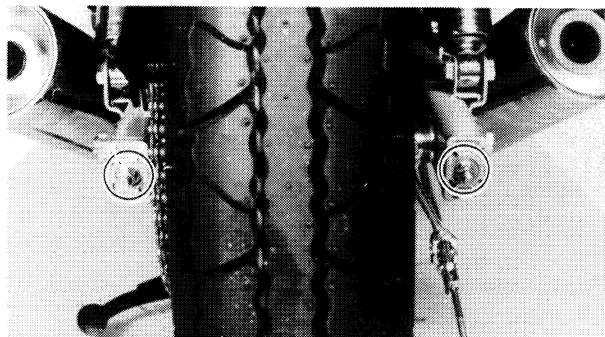

4. Loosen:
 - Lock nuts (Drive chain)
 - Adjuster (Drive chain)

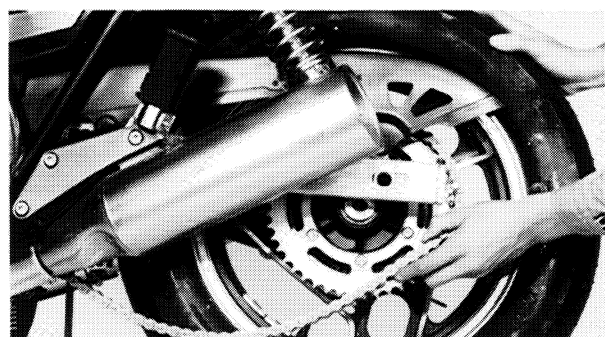

5. Remove:
 - Cotter pin
 - Nut
 - Rear axle
 - Rear wheel

INSPECTION

1. Inspect:
 - Rear axle
Refer to "FRONT WHEEL-INSPECTION" section.

2. Inspect:
 - Wheel runout
Refer to "FRONT WHEEL-INSPECTION" section.

3. Inspect:
 - Wheel
Refer to "FRONT WHEEL-INSPECTION" section.

4. Check:
 - Wheel bearings
Refer to "FRONT WHEEL-INSPECTION" section.

5. Check:
 - Wheel balance
Refer to "FRONT WHEEL-INSPECTION" section.

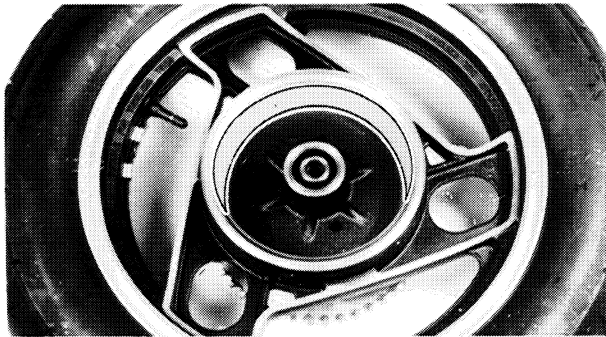

6. Inspect:
 - Brake lining surface
Glazed areas → Remove.
Use a coarse sand paper.

NOTE: _____
After using the sand paper, clean of the polished particles with cloth.

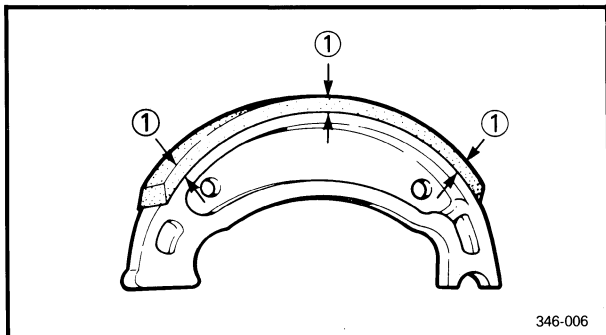

7. Measure:
 - Brake lining thickness
Out of specification → Replace.

① Measuring points

	<p>Brake Lining Thickness: 4 mm (0.16 in)</p> <p>Wear Limit: 2 mm (0.08 in)</p>
---	---

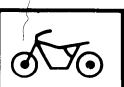

NOTE:

Replace the brake shoes as a set if either is found to be worn to the wear limit.

8. Inspect:

- Brake drum inner surface
Oil/Scratches → Remove.

Oil	Use a rag soaked in lacquer thinner or solvent.
Scratches	Use a emery cloth (lightly and evenly polishing)

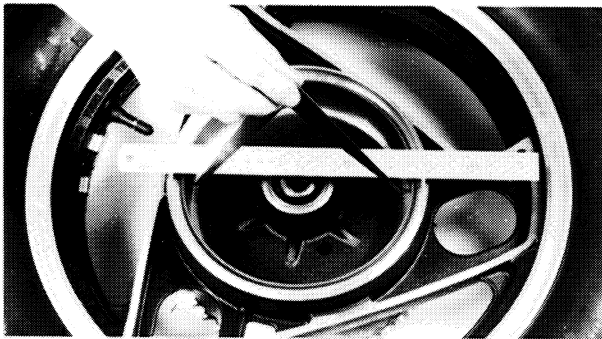

9. Measure:

- Brake drum inside diameter
Out of specification → Replace rear wheel.

	Brake Drum Inside Diameter: 180 mm (7.08 in)
	Wear Limit: 181 mm (7.12 in)

10. Inspect:

- Camshaft face
Wear → Replace.

ASSEMBLY (BRAKE SHOE PLATE)

When assembling the brake shoe plate, reverse the disassembly procedure.

Note the following points.

1. Apply:

- Lithium-soap base grease
(to the brake cam shaft)

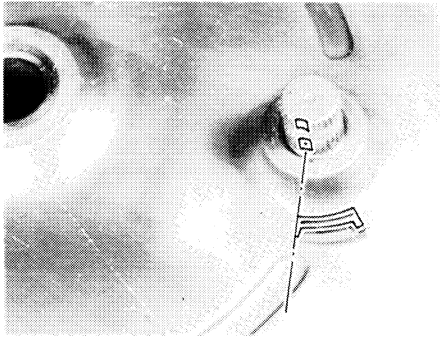

2. Install:
 - Brake cam shaft

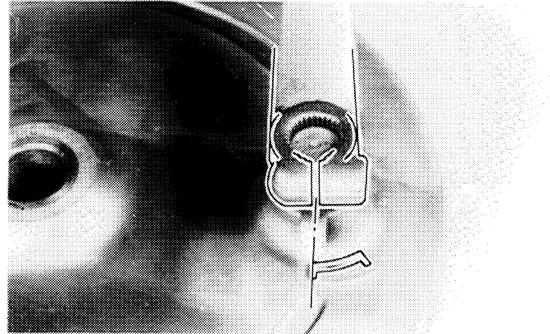

3. Install:
 - Cam shaft lever

INSTALLATION

When installing the rear wheel, reverse the removal procedure.

Note the following points.

1. Apply:
 - Lithium base grease

Lightly grease to the oil seal lips.
2. Adjust:
 - Drive chain slack



Drive Chain Slack:

20 ~ 30 mm (0.8 ~ 1.2 in)

Refer to "CHAPTER 2-DRIVE CHAIN SLACK ADJUSTMENT" section.

3. Tighten:
 - Axle nut



105 Nm (10.5 m•kg, 75 ft•lb)

- Nut (Tension bar)



20 Nm (2.0 m•kg, 14 ft•lb)



4. Install:
- Cotter pin

WARNING:

Always use a new cotter pin on the axle nut.

5. Adjust:
- Brake pedal free play



Free Play:
20 ~ 30 mm (0.8 ~ 1.2 in)

Refer to "CHAPTER 2-BRAKE PEDAL FREE PLAY ADJUSTMENT" section.

WARNING:

Check the operation of the brake light after adjusting the rear brake.

FRONT BRAKE

BRAKE CALIPER

- ① Brake disc (Right)
- ② Brake disc (Left)
- ③ Brake caliper (Right)
- ④ Brake caliper (Left)
- ⑤ Piston
- ⑥ Piston seal
- ⑦ Dust seal
- ⑧ Brake pad
- ⑨ Pad spring

* Install the pad spring with its longer tangs facing towards the disc rotation direction.

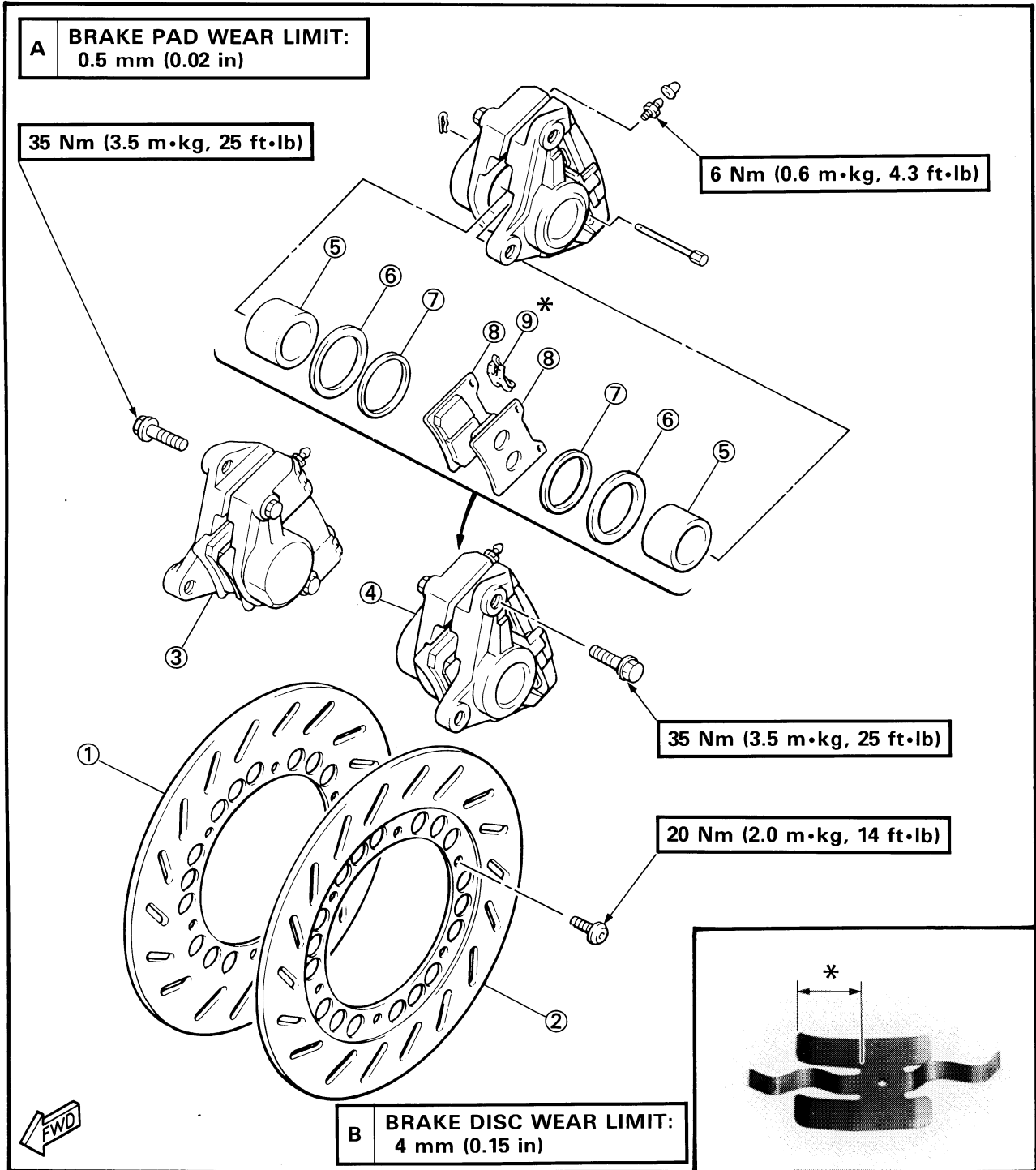



BRAKE MASTER CYLINDER

- ① Master cylinder assembly
- ② Master cylinder cap
- ③ Rubber seal
- ④ Master cylinder kit
- ⑤ Copper washer
- ⑥ Brake hose
- ⑦ Joint

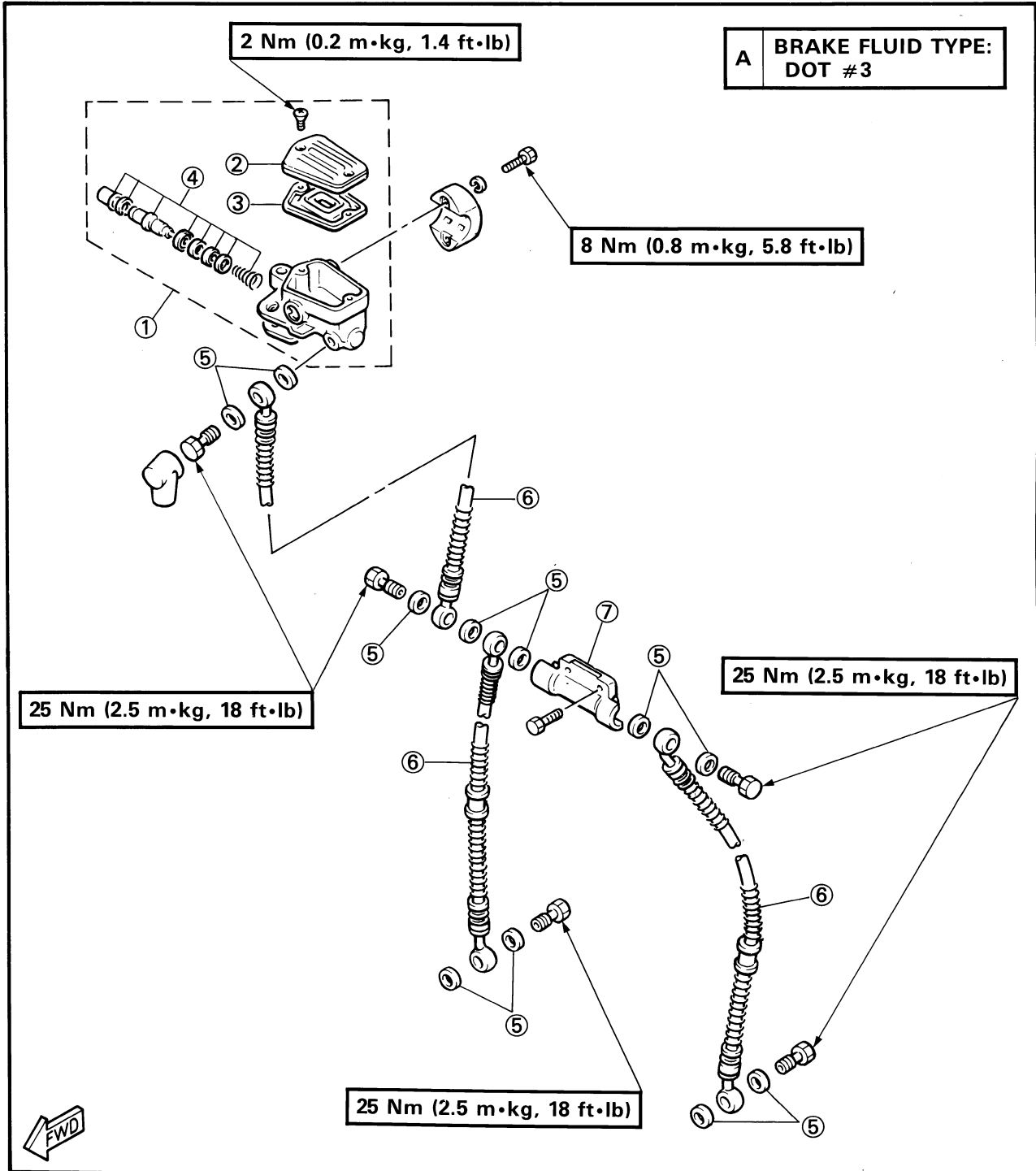

**CAUTION:**

Disc brake components rarely require disassembly. Do not disassemble components unless absolutely necessary. If any hydraulic connection in the system is opened, the entire system should be disassembled, drained, cleaned and then properly filled and bled upon reassembly. Do not use solvents on brake internal components. Solvents will cause seals to swell and distort. Use only clean brake fluid for cleaning. Use care with brake fluid. Brake fluid is injurious to eyes and will damage painted surfaces and plastic parts.

CALIPER PAD REPLACEMENT**NOTE:**

It is not necessary to disassemble the brake caliper and brake hose to replace the brake pads.

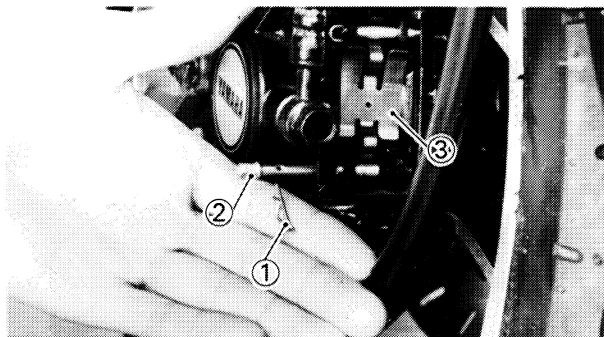

1. Remove:
 - Cover
 - Clips ①
 - Pins ②
 - Pad spring ③

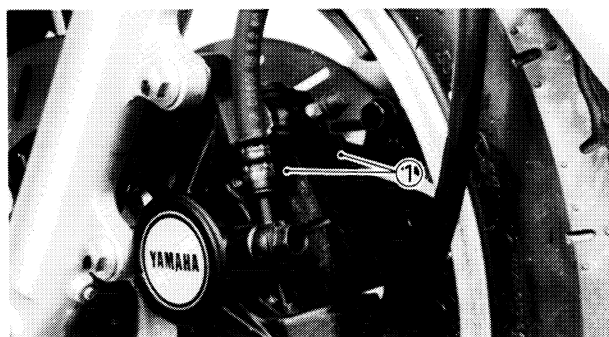

2. Replace:
 - Brake pads ①

NOTE:

Replace the pads as a set if either is found to be worn to the wear limit.

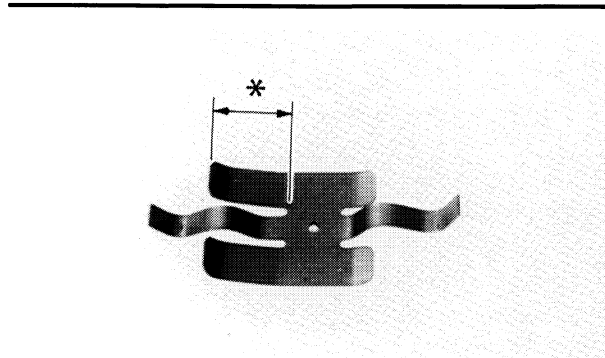

3. Install:
 - Pad spring
 - Pins
 - Clips
 - Cover

NOTE: _____

Install the pad spring with its longer tangs facing towards the disc rotation direction.

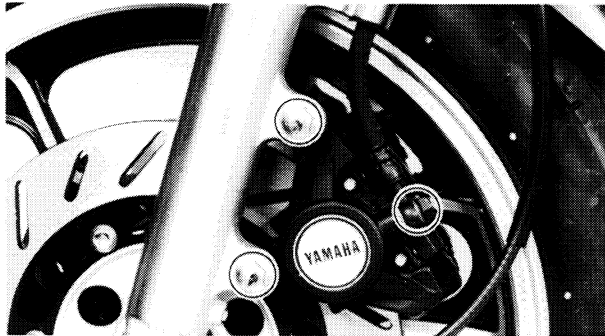

CALIPER DISASSEMBLY

NOTE: _____

Before disassembling the caliper, drain the brake fluid.

1. Remove:
 - Brake caliper

2. Remove:
 - Brake pad

Refer to "CALIPER PAD REPLACEMENT" section.

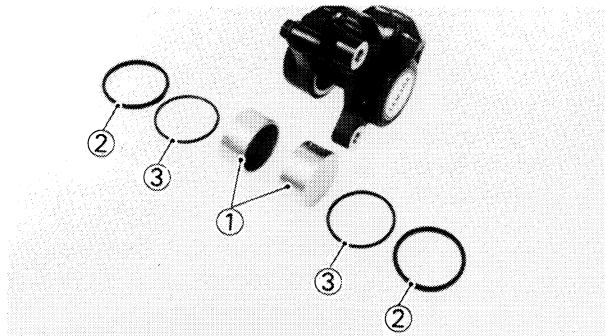

3. Remove:
 - Piston ①
 - Piston seal ②
 - Dust seal ③

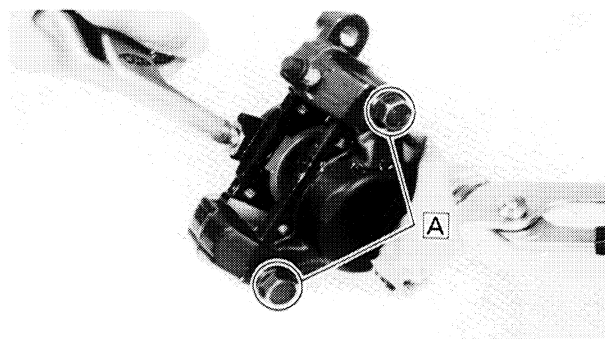

A DO NOT LOOSEN

Caliper piston removal steps:

- Using a rag, lock the right side piston.
- Blow compressed air into the hose joint opening to force out the left side piston from the caliper body.
- Remove the dust and piston seals and reinstall the piston.
- Repeat previous step to force out the right side piston from the caliper body.

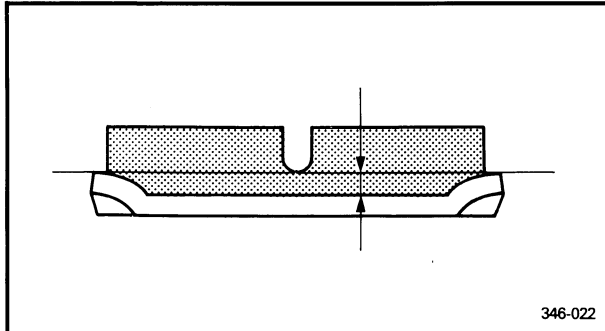

INSPECTION

1. Inspect:

- Caliper piston
Rust/Wear → Replace.
- Caliper cylinder body
Wear/Scratches → Replace.

- Brake pads
Out of specification → Replace.



Pad Wear Limit:
0.5 mm (0.02 in)

INSTALLATION

1. Assemble:

- Brake caliper(s)
Reverse disassembly steps.

WARNING:

- All internal parts should be cleaned in new brake fluid only.
- Internal parts should be lubricated with brake fluid when installed.



Brake Fluid:
DOT #3

- Replace the dust and piston seals whenever a caliper is disassembled.

2. Install:

- Brake caliper
- Brake hose

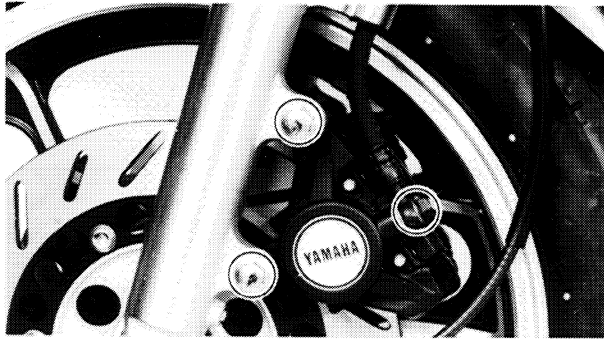

3. Tighten:
 - Bolt (Brake hose)
 - Bolts (Caliper)



Bolt (Brake hose):
 25 Nm (2.5 m•kg, 18 ft•lb)
Bolts (Caliper):
 35 Nm (3.5 m•kg, 25 ft•lb)

4. Fill:
 - Brake system



Recommended Brake Fluid:
 DOT #3

5. Bleed the air completely from the brake system.
 Refer to "AIR BLEEDING" section.
6. Check:
 - Brake fluid level
 Refer to "CHAPTER 2-FRONT BRAKE FLUID INSPECTION" section.

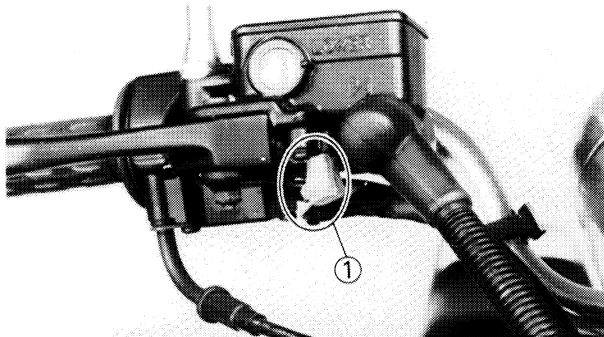

MASTER CYLINDER DISASSEMBLY

NOTE:

Before disassembling the master cylinder, drain the brake fluid.

1. Disconnect:
 - Brake switch leads ①
2. Remove:
 - Brake hose ①
 - Brake lever ②
 - Spring ③



3. Remove:
- Master cylinder assembly

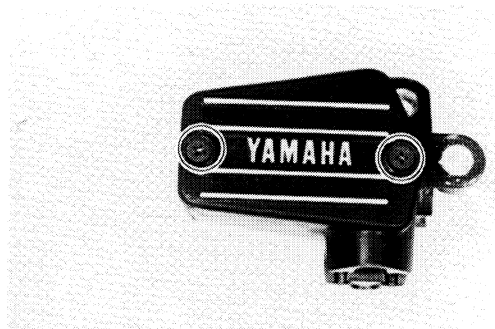

4. Remove:
- Master cylinder cap
 - Rubber seal

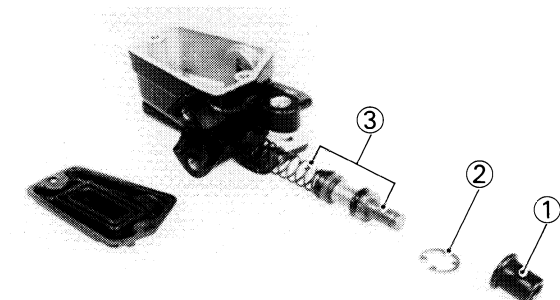

5. Remove:
- Dust boot ①
 - Circlip ②
 - Master cylinder kit ③

INSPECTION

1. Inspect:
- Master cylinder body
Scratches/Wear → Replace.

NOTE: _____
 Clean all passages with new brake fluid.

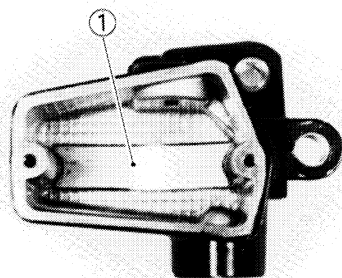

- Brake hoses
Cracks/Wear/Damage → Replace.
- Master cylinder kit
Scratches/Wear → Replace.

- ① Oil baffle plate

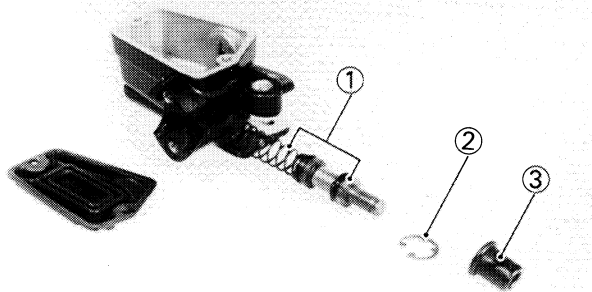
**INSTALLATION**

1. Install:

- Master cylinder kit ①

WARNING:

Internal parts should be lubricated with brake fluid when installed.

- Circlip ②
- Dust boot ③

2. Install:

- Master cylinder
- Brake hose (With copper washers)
- Brake lever

NOTE:

Grease the pivot point.

3. Tighten:

- Bolts (Master cylinder bracket)
- Bolt (Brake hose)



Bolts (Master cylinder bracket):

8 Nm (0.8 m•kg, 5.8 ft•lb)

Bolt (Brake hose):

25 Nm (2.5 m•kg, 18 ft•lb)

4. Connect:

- Brake switch leads

5. Fill:

- Brake system



Recommended Brake Fluid:

DOT #3

6. Bleed the air completely from the brake system.

Refer to "AIR BLEEDING" section.

7. Check:

- Brake fluid level
Refer to "CHAPTER 2-FRONT BRAKE FLUID INSPECTION" section.



AIR BLEEDING

WARNING:

Bleed the brake system if:

- The system has been disassembled.
- A brake hose has been loosened or removed.
- The brake fluid is very low.
- The brake operation is faulty.

A dangerous loss of braking performance may occur if the brake system is not properly bled.

1. Air bleeding



Air bleeding steps:

- a. Add proper brake fluid to the reservoir.
- b. Install diaphragm.
Be careful not to spill any fluid or allow the reservoir to over flow.
- c. Connect the clear plastic tube (4.5 mm, 3/16 in inside dia.) tightly to the caliper bleed screw ①.
- d. Place the other end of the tube into a container.
- e. Slowly apply the brake lever several times.
- f. Pull the lever in. Hold the lever in position.
- g. Loosen the bleed screw and allow the lever to travel towards its limit.
- h. Tighten the bleed screw when the lever limit has been reached; then release the lever.
- i. Repeat steps (e) to (h) until of the air bubbles have been removed from the system.

NOTE:

If bleeding is difficult, it may be necessary to let the brake fluid system stabilize for a few hours. Repeat the bleeding procedure when the tiny bubbles in system have disappeared.

2. Tighten:

- Bleed screw
- Screws (Master cylinder cap)



Bleed Screw:

6 Nm (0.6 m•kg, 4.3 ft•lb)

Screws (Master cylinder cap):

2 Nm (0.2 m•kg, 1.4 ft•lb)

FRONT BRAKE

CHAS



MEMO



FRONT FORK

- ① Front fork assembly (Right)
- ② Front fork assembly (Left)
- ③ Cap bolt
- ④ O-ring
- ⑤ Spring seat
- ⑥ Fork spring
- ⑦ Damper rod
- ⑧ Inner fork tube
- ⑨ Oil lock piece
- ⑩ Dust seal
- ⑪ Retaining clip
- ⑫ Oil seal
- ⑬ Plain washer
- ⑭ Guide bush
- ⑮ Outer fork tube
- ⑯ Drain screw

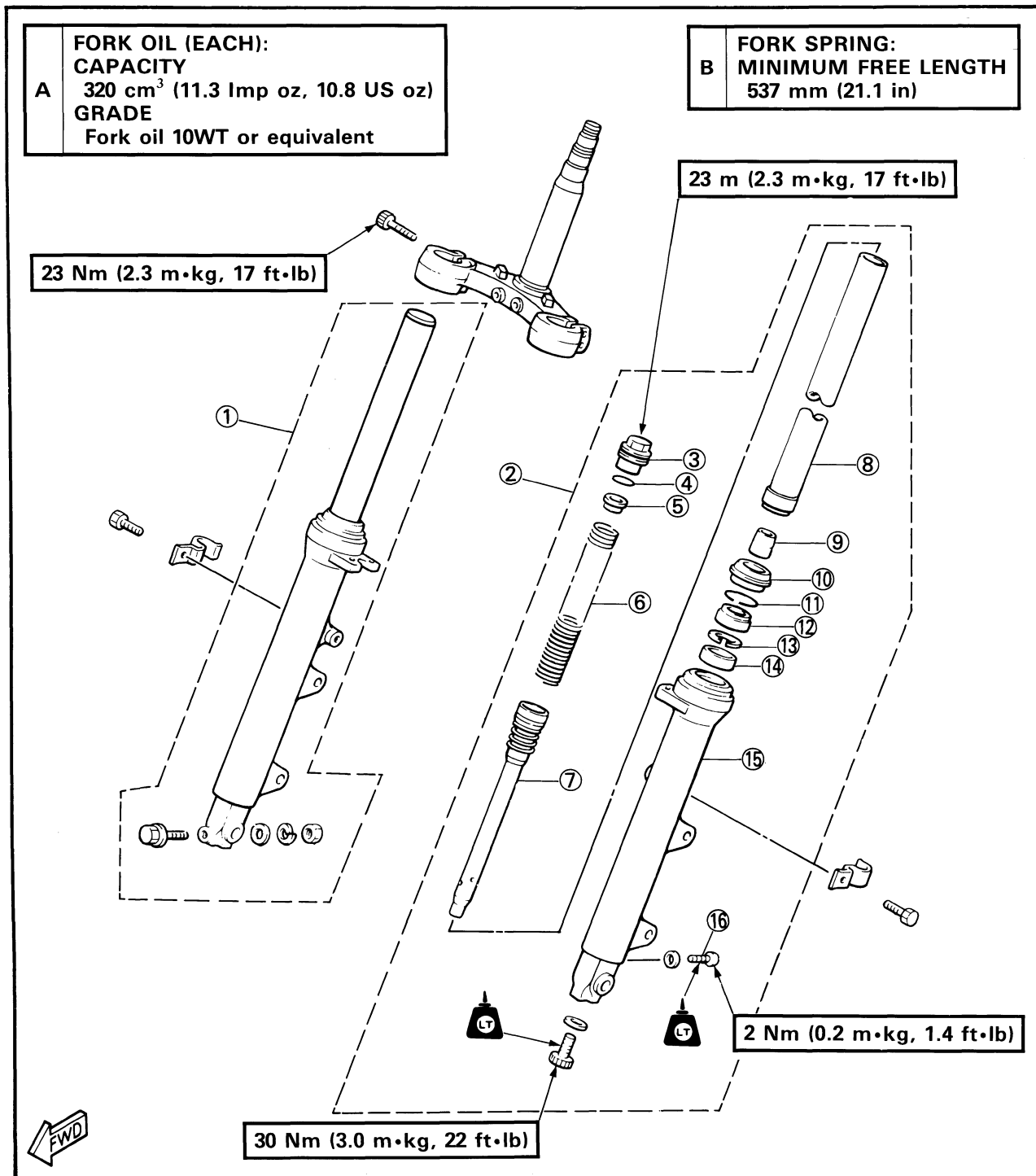

**REMOVAL**

1. Place the motorcycle on its centerstand.

WARNING:

Support the motorcycle securely so there is no danger of it falling over.

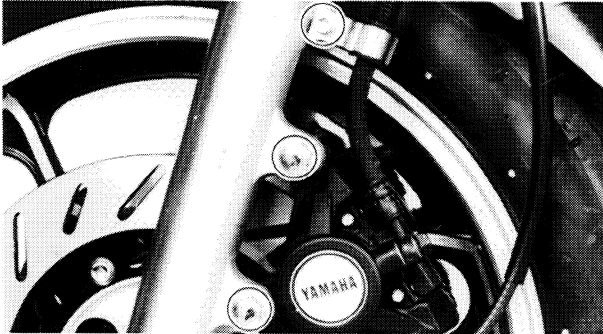

2. Remove:
 - Bolts (Brake caliper)

3. Remove:
 - Front wheel
 Refer to "FRONT WHEEL-REMOVAL" section.

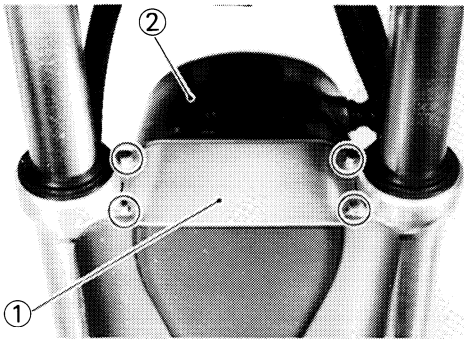

4. Remove:
 - Front fork brace ①
 - Front fender ②

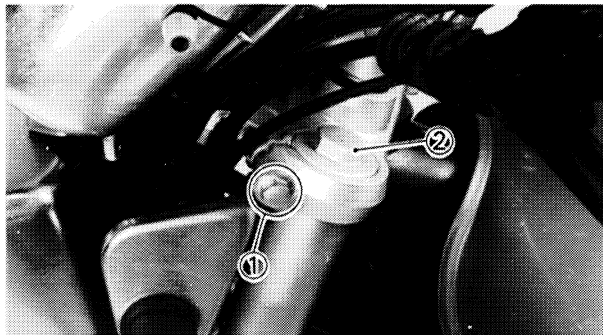

5. Loosen:
 - Pinch bolt (Handle crown) ①
 - Cap bolt ②

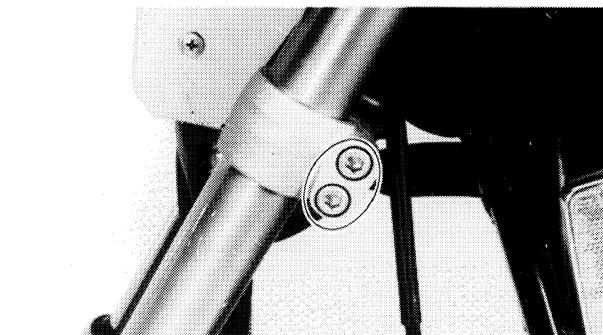

6. Loosen:
 - Pinch bolts (Under bracket)

CAUTION:

Support the fork before loosening the pinch bolts.

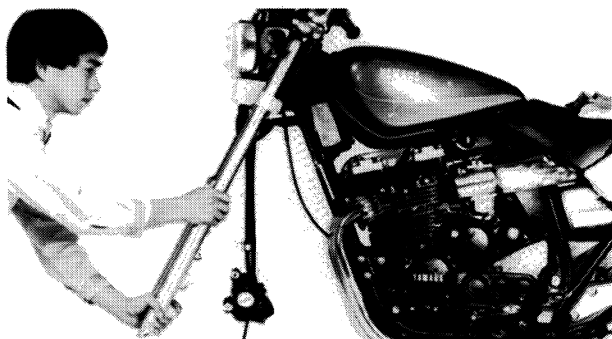

7. Remove:
- Front fork

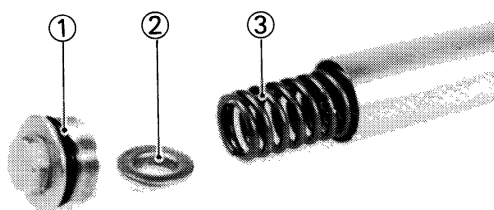

DISASSEMBLY

1. Remove:
- Cap bolt ①
 - Spring seat ②
 - Fork spring ③

2. Drain:
- Fork oil

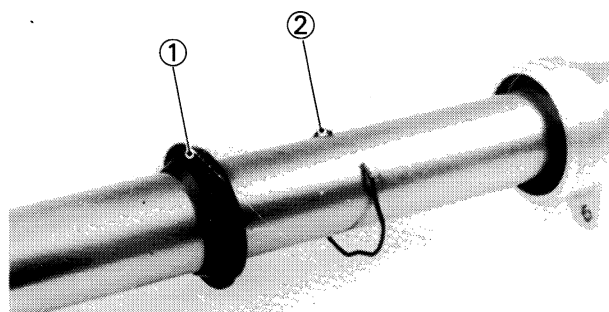

3. Remove:
- Dust seal ①
 - Retaining clip ②

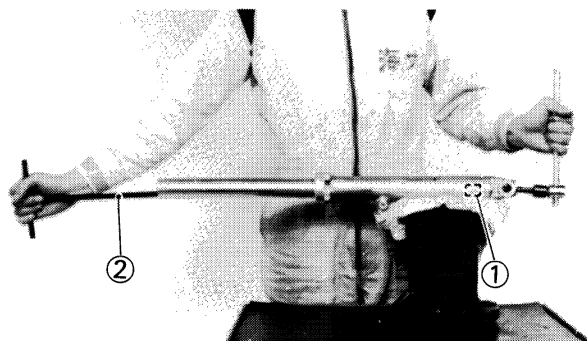

4. Remove:
- Cylinder securing bolt
- Use the Holder (YM-33298) ① and T-Handle (YM-01326) ② to lock the damper rod.

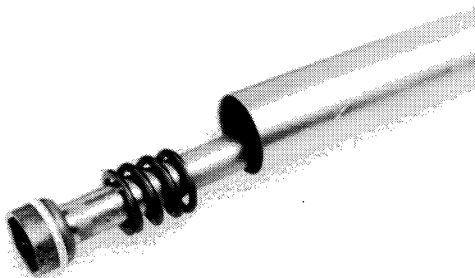

5. Remove:
- Damper rod

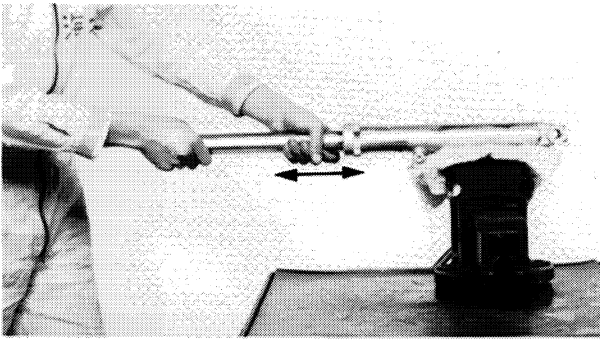

6. Remove:
- Inner fork tube

Inner fork tube removal steps:

- Hold the fork leg horizontally.
- Pull out the inner fork tube from the outer tube by forcefully, but carefully, withdrawing the inner fork tube.

NOTE:

- Excessive force will damage the oil seal, plain washer and/or bushings. The oil seal and bushings must be replaced.
- Avoid bottoming the inner tube in the outer tube during the above procedure, as the oil lock piece will be damaged.

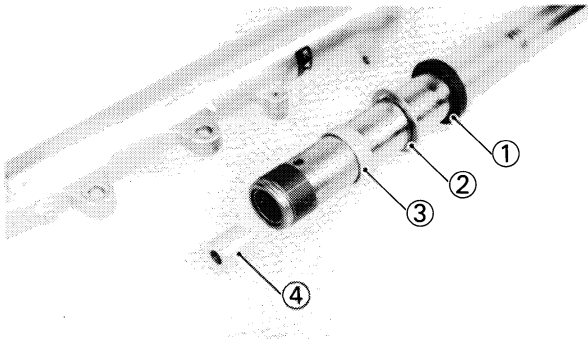

7. Remove:
- Oil seal ①
 - Plain washer ②
 - Guide bush ③
 - Oil lock piece ④

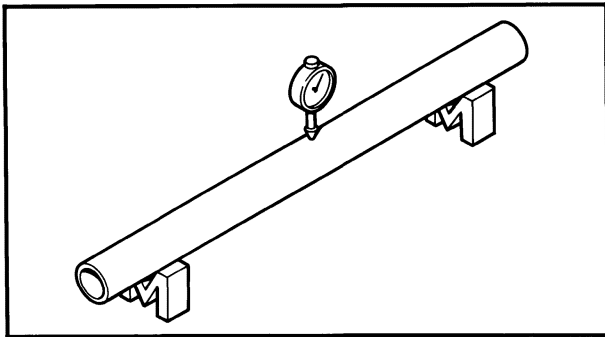

INSPECTION

1. Inspect:
- Inner fork tube
Scratches/Bends → Replace.

WARNING:

Do not attempt to straighten a bent inner fork tube as this may dangerously weaken the tube.

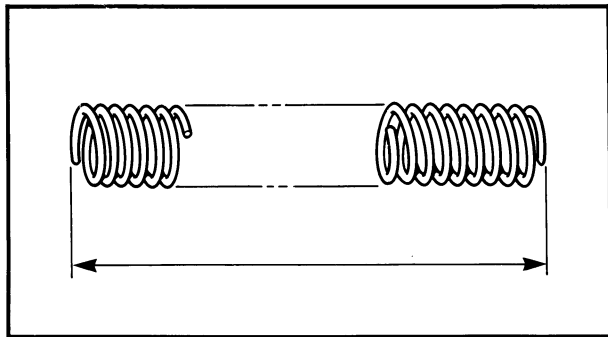
2. Inspect:
- Outer fork tube
Scratches/Bends/Damage → Replace.



3. Measure:

- Fork spring
- Out of specification → Replace.



Fork Spring Free Length:

542 mm (21.3 in)

Minimum Free Length:

537 mm (21.1 in)

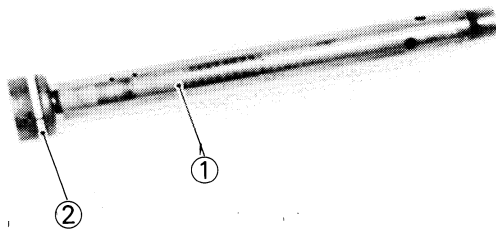

4. Inspect:

- Damper rod ①
- Ring ②
- Wear/Damage → Replace.

NOTE:

Blow out all oil passages with compressed air.



5. Inspect:

- Oil lock piece ①
- O-ring ②
- Damage → Replace.

REASSEMBLY**NOTE:**

- In front fork reassembly, be sure to use following new parts.
 - * Guide bush
 - * Slide bush
 - * Oil seal
 - * Dust seal
- Make sure all components are clean before reassembly.

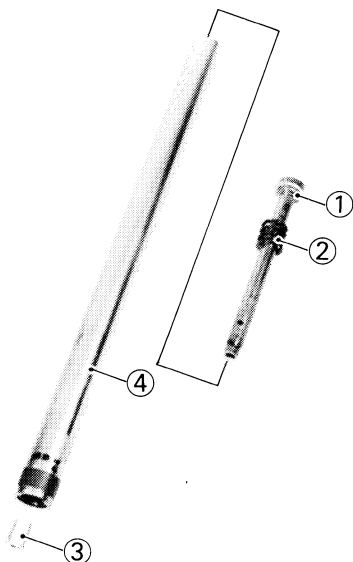

1. Install:

- Damper rod ①
- Rebound spring ②
- Oil lock piece ③
- Inner fork tube ④



2. Install:

- Cylinder securing bolt

Use the Holder (YM-33298) and T-Handle (YM-01326) to lock the damper rod.



30 Nm (3.0 m•kg, 22 ft•lb)
Apply **LOCTITE®**.

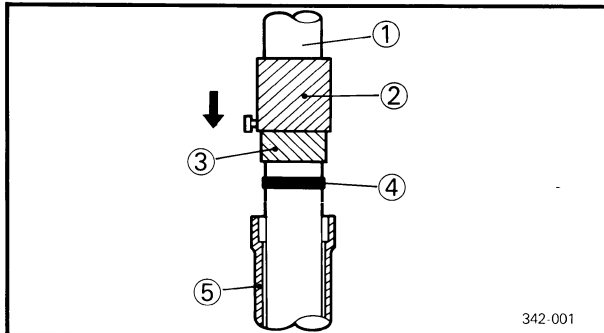

342-001

3. Install:

- Guide bush (4)

Use the Fork Seal Driver Weight (YM-33963)

(2) and Adapter (YM-08010) (3).

- ① Inner tube
- ⑤ Outer tube

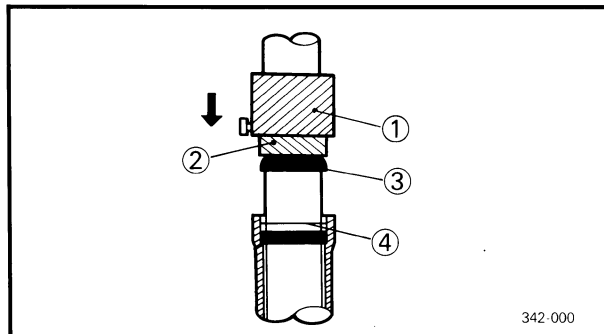

342-000

4. Install:

- Plain washer (4)

- Oil seal (3) (New)

Use the Fork Seal Driver Weight (YM-33963)

(1) and Adapter (YM-08010) (2).

- Retaining clip

- Dust seal

5. Fill:

- Front fork

5



Each Fork:

320 cm³ (11.3 Imp oz, 10.8 US oz)

Fork Oil 10 WT or equivalent

After filling, slowly pump the fork up and down to distribute oil.

6. Install:

- Fork spring (with smaller pitch side up)
- Spring seat
- Cap bolt (Temporarily)

**INSTALLATION**

When installing the front fork, reverse the removal procedure.

Note the following points.

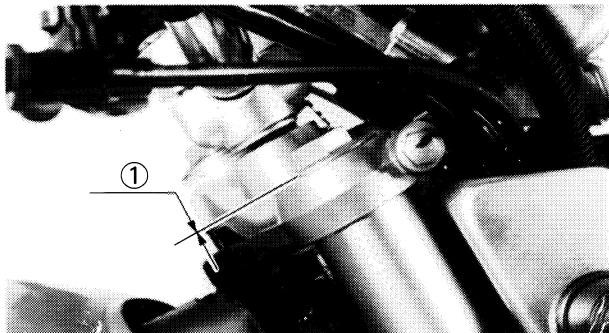

1. Install:

- Front fork(s)

Temporarily tighten the pinch bolts.

NOTE: _____

Level the top of the cap bolt with the top of the handle crown.

① Flush

2. Tighten:

- Pinch bolts (Under bracket)



Pinch Bolt (Under Bracket)
23 Nm (2.3 m•kg, 17 ft•lb)

NOTE: _____

Do not tighten the handle crown pinch bolt.

3. Tighten:

- Cap bolt
- Pinch bolt (Handle crown)



Cap Bolt:
23 Nm (2.3 m•kg, 17 ft•lb)
Pinch Bolt (Handle crown):
20 Nm (2.0 m•kg, 14 ft•lb)

4. Install:

- Front fender
- Front fork brace



Bolts (Front Fender):
8 Nm (0.8 m•kg, 5.8 ft•lb)



5. Install:

- Front wheel
- Brake caliper

Refer to "FRONT WHEEL-INSTALLATION" section.



Nut (Front Axle):

105 Nm (10.5 m•kg, 75 ft•lb)

Bolts (Brake Caliper):

35 Nm (3.5 m•kg, 25 ft•lb)

STEERING HEAD

- ① Steering stem bolt
- ② Handle crown
- ③ Ring nut
- ④ Bearing race cover
- ⑤ Bearing race
- ⑥ Bearing
- ⑦ Bearing race
- ⑧ Bearing race
- ⑨ Bearing
- ⑩ Bearing race
- ⑪ Dust seal
- ⑫ Under bracket

* Tighten to specified torque.
If steering is binded, loosen the ring nut so that there is no free play on bearing.

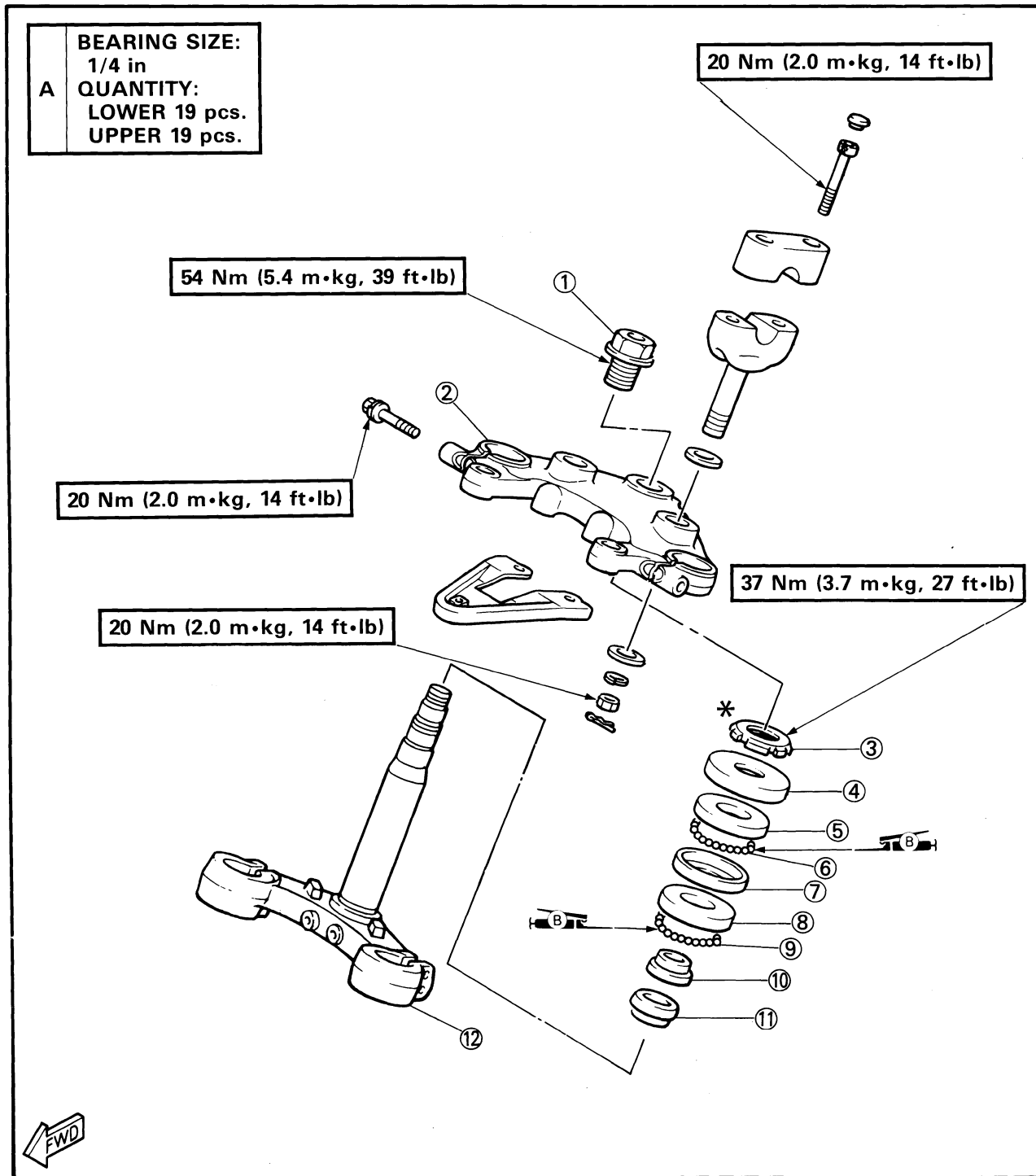

**REMOVAL**

1. Place the motorcycle on the centerstand.

WARNING:

Securely support the motorcycle so there is no danger of it falling over.

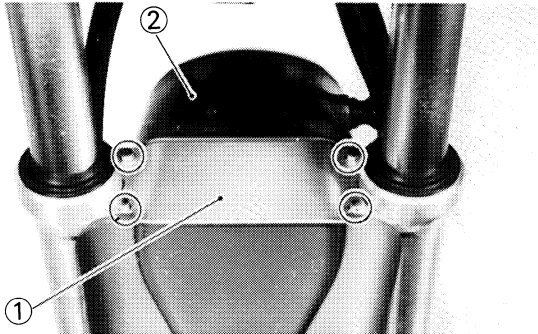

2. Remove:
 - Front wheel
Refer to "FRONT WHEEL-REMOVAL" section.

3. Remove:
 - Front fork brace ①
 - Front fender ②

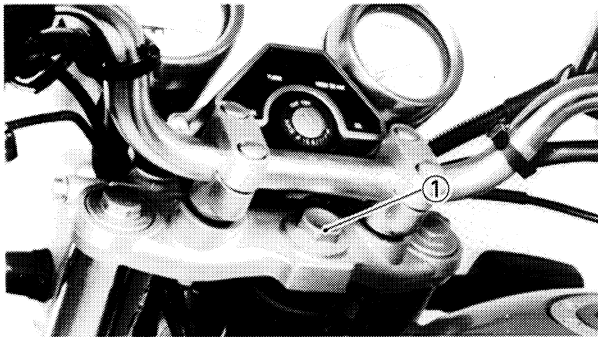

4. Loosen:
 - Steering stem bolt ①

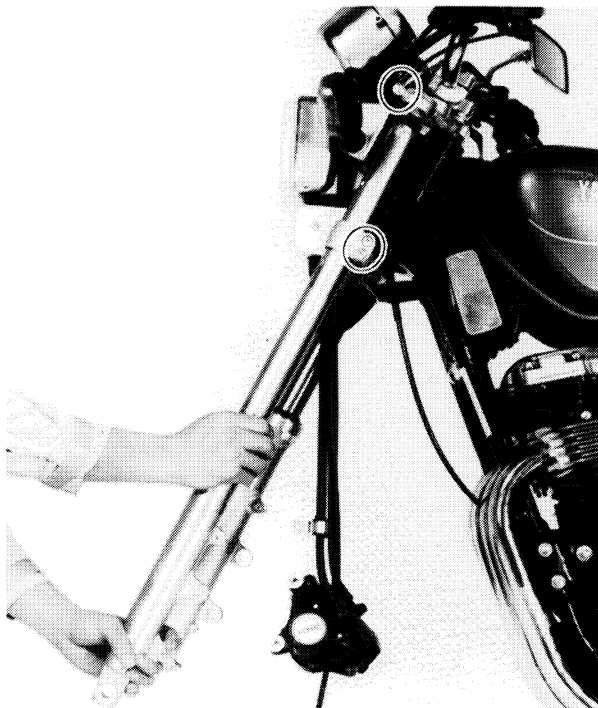

5. Remove:
 - Front forks

5

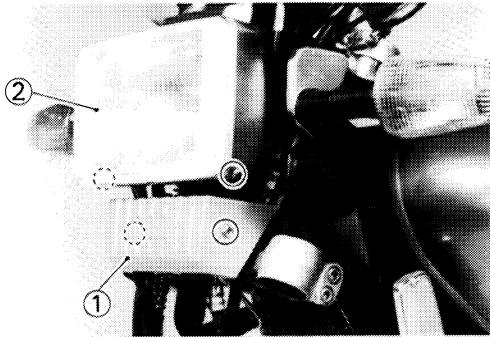

6. Remove:
- Front cover ①
 - Headlight lens unit ②

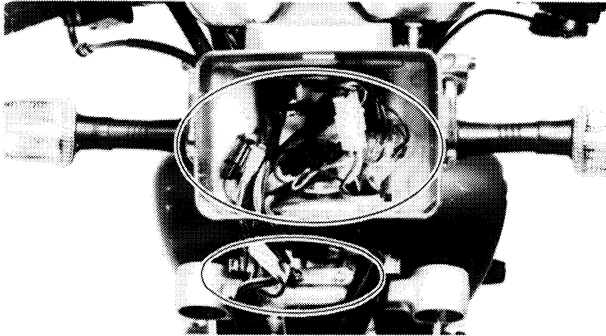

7. Disconnect:
- Meter leads
 - Handlebar switch leads
 - Flasher light leads

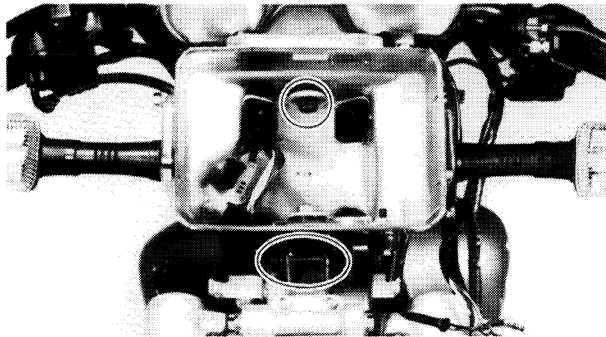

8. Remove:
- Headlight body

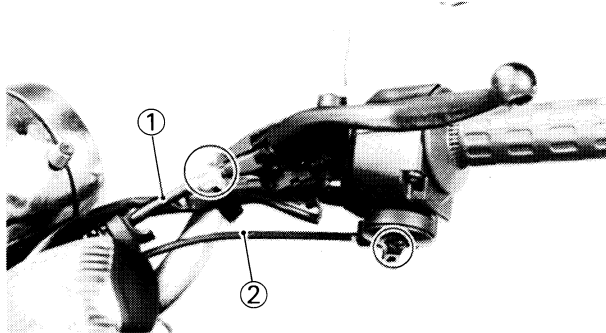

9. Remove:
- Clutch cable ①
 - Starter cable ②

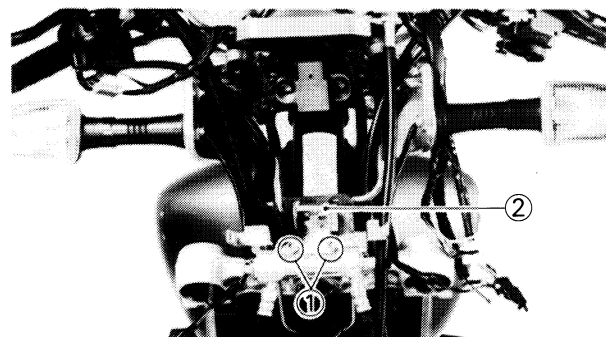

10. Remove:
- Bolts (Brake hose joint) ①
 - Headlight stay ②

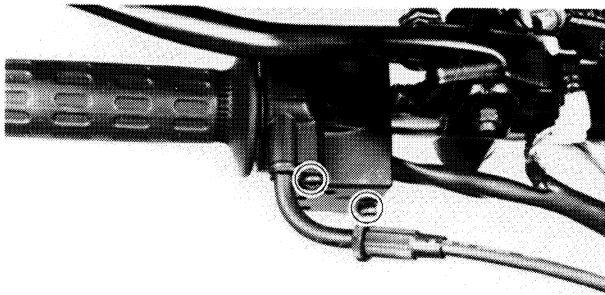

11. Loosen:
- Screws (Right handlebar switch)

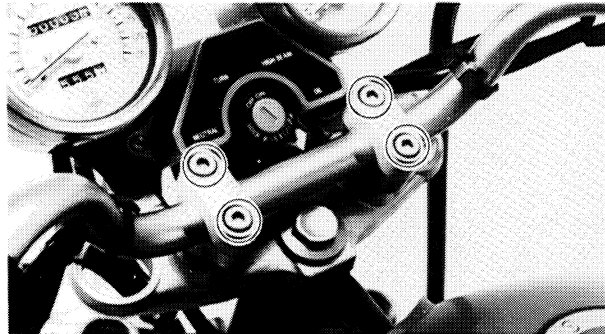

12. Remove:
- Handlebar

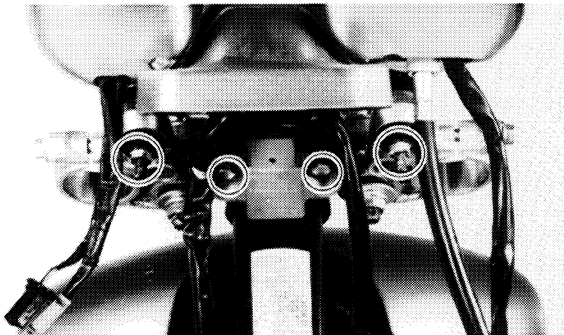

13. Remove:
- Meter assembly
 - Main switch

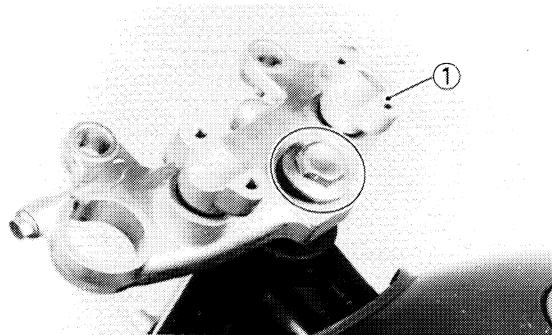

14. Remove:
- Handle crown ①

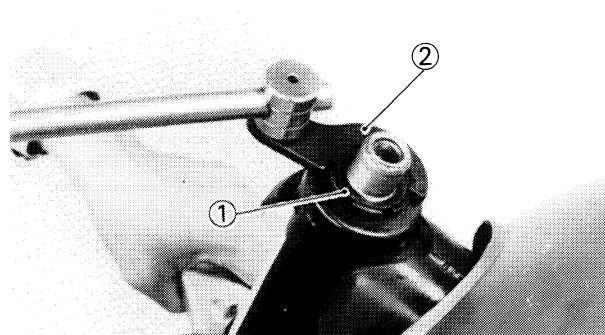

15. Remove:
- Ring nut ①
 - Use Ring Nut Wrench (YU-33975) ②.

WARNING:

Support the under bracket so that it may not fall down.

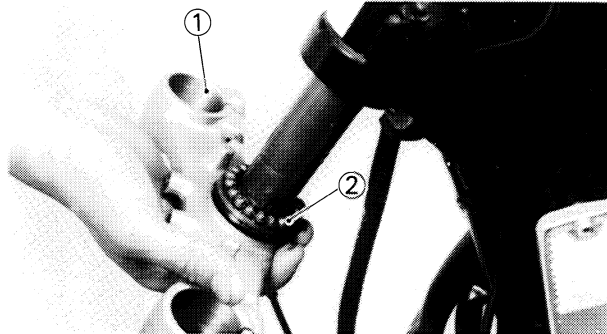
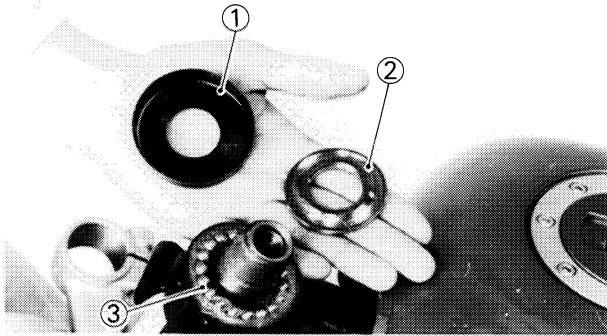

16. Remove:

- Bearing race cover ①
- Bearing race ②
- Bearings ③

17. Remove:

- Under bracket ①
- Bearings ②

INSPECTION

1. Wash the bearings in a solvent.
2. Inspect:
 - Bearings
 - Ball races
 - Pitting/Damage → Replace.

NOTE: _____

Always replace bearings and races as a set.

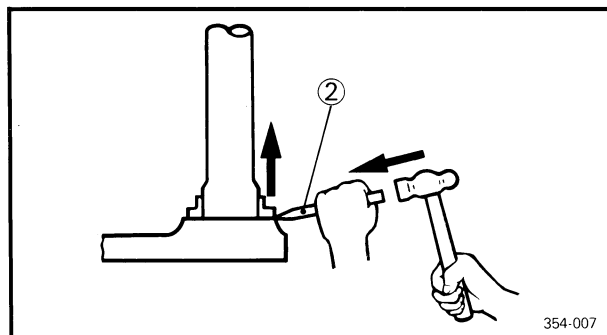
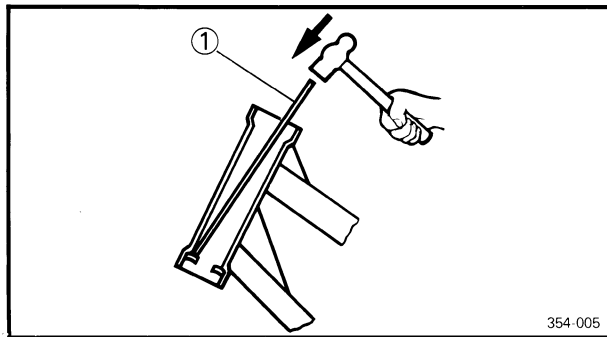

Bearing race replacement steps:

- Remove the bearing races using long rod ① and the hammer as shown.
- Remove the bearing race on the under bracket using the floor chisel ② and the hammer as shown.
- Install the new dust seal and races.

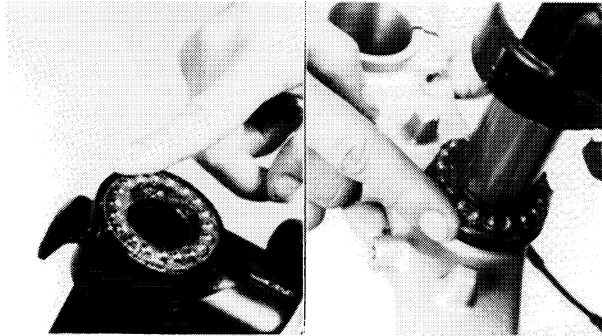

INSTALLATION

Reverse the removal procedure.

Note the following points.

1. Apply:
 - Grease
 To bearing races.

	Wheel Bearing Grease
---	-----------------------------

2. Install:
 - Bearings
 Arrange the bearings around race, and apply more grease.

Ball Quantity/Size
Upper 19 pcs./1/4 in
Lower 19 pcs./1/4 in

3. Install:
 - Under bracket

CAUTION:

Hold the under bracket until it is secured.



4. Tighten:
 - Ring nut
 Use Ring Nut Wrench (YU-33975).

	37 Nm (3.7 m•kg, 27 ft•lb)
---	-----------------------------------

NOTE:

If steering is binded, loosen the ring nut so that there is no free play on bearings.

5. Tighten:
 - Bolts (Handlebar)

	20 Nm (2.0 m•kg, 14 ft•lb)
---	-----------------------------------



6. Pass the meter leads, handlebar switch leads and the flasher light leads through the headlight body holes.

Refer to "CHAPTER 7-CABLE ROUTING" section.

7. Connect:

- Meter leads
- Handlebar switch leads
- Flasher light leads

NOTE: _____

The leads of identical colors should be connected.

8. Install:

- Front forks

Refer to "FRONT FORK-INSTALLATION" section.



Pinch Bolts (Under Bracket):

23 Nm (2.3 m•kg, 17 ft•lb)

Pinch Bolts (Handle Crown):

20 Nm (2.0 m•kg, 14 ft•lb)

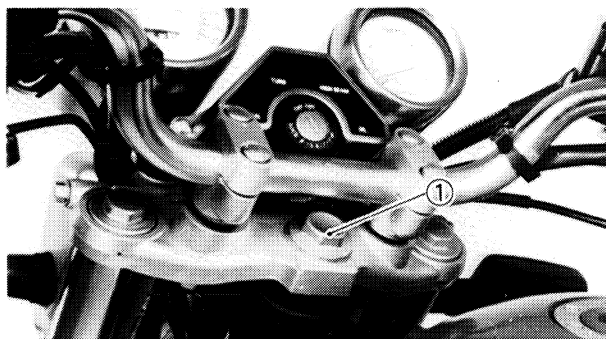

9. Tighten:

- Steering stem bolt ①



54 Nm (5.4 m•kg, 39 ft•lb)

10. Install:

- Front fender
- Front fork brace



Bolt (Front Fender):

8 Nm (0.8 m•kg, 5.8 ft•lb)



11. Install:

- Front wheel
- Brake caliper

Refer to "FRONT WHEEL-INSTALLATION" section.



Nut (Front Axle):

105 Nm (10.5 m•kg, 75 ft•lb)

Bolts (Brake Caliper):

35 Nm (3.5 m•kg, 25 ft•lb)

12. Bleed the air completely from the brake system.

Refer to "FRONT BRAKE-AIR BLEEDING" section.



REAR SHOCK ABSORBER

- ① Rear shock absorber (Right)
- ② Rear shock absorber (Left)

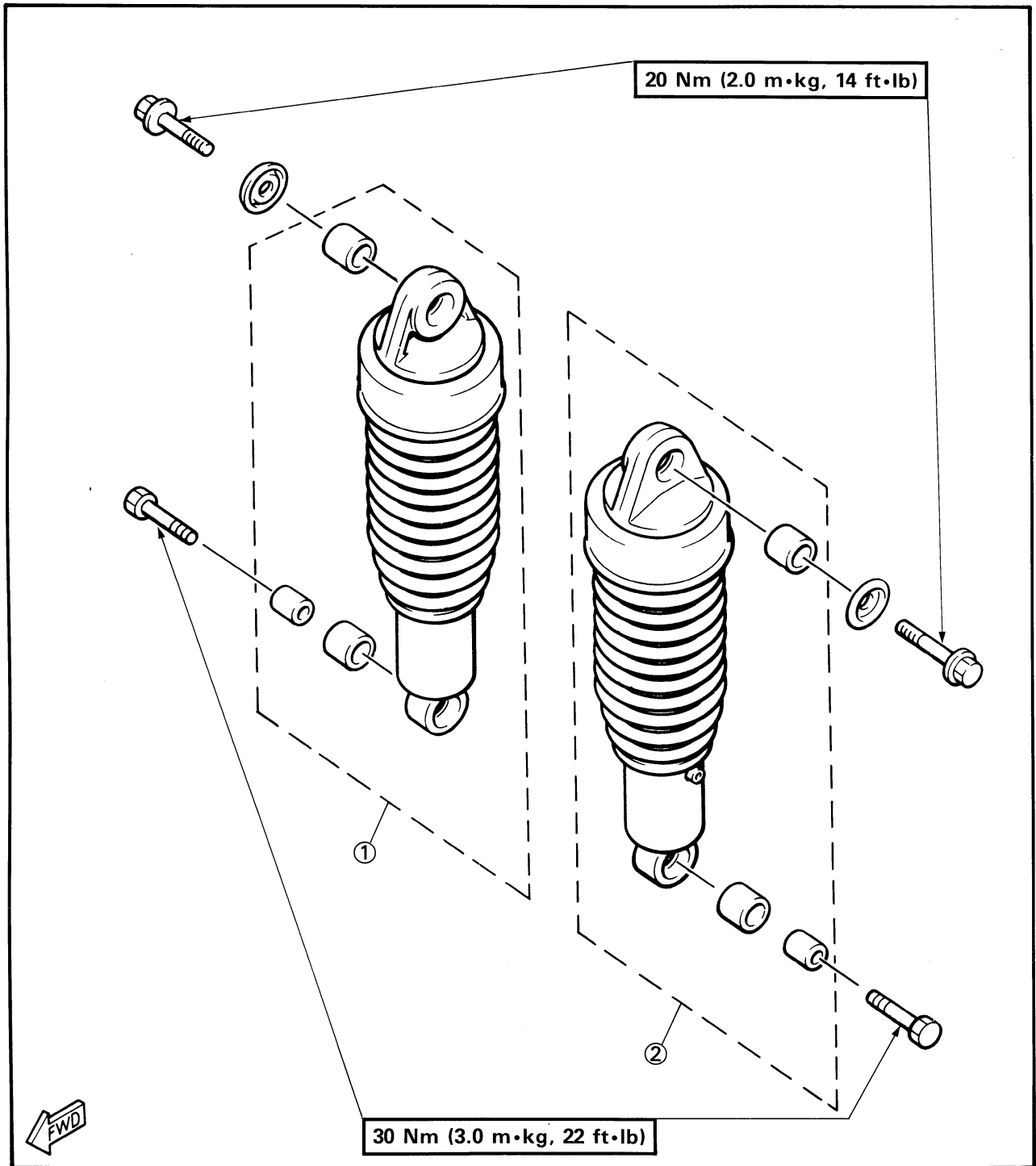

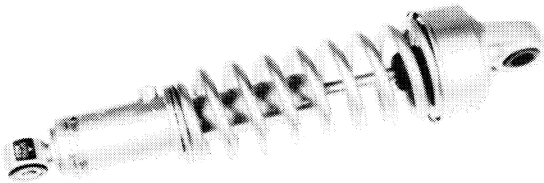
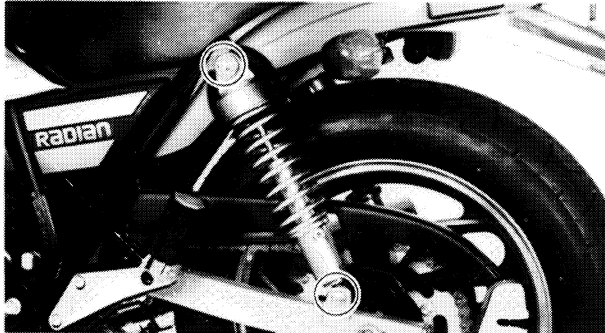
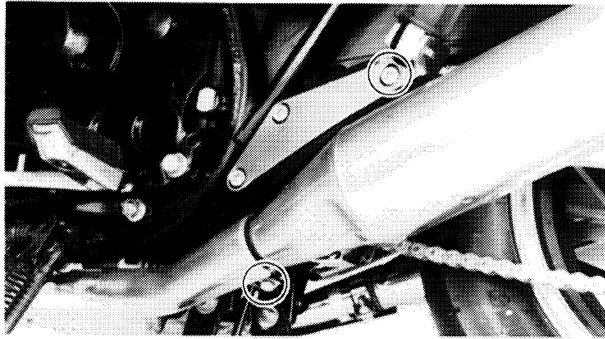

REMOVAL

1. Place the motorcycle on its centerstand.
2. Remove:
 - Muffler
3. Remove:
 - Rear shock absorber

INSPECTION

1. Inspect:
 - Rear shock absorber
 - Oil leaks/Damage → Replace.

INSTALLATION

Reverse the removal procedure.
Note the following points.

1. Install:
 - Rear shock absorber

	Bolt (Shock Absorber and Frame): 20 Nm (2.0 m•kg, 14 ft•lb) Bolt (Shock Absorber and Swingarm): 30 Nm (3.0 m•kg, 22 ft•lb)
--	---

2. Install:
 - Muffler

	Bolt (Muffler and Footrest Bracket): 25 Nm (2.5 m•kg, 18 ft•lb)
--	---



SWINGARM

- ① Swingarm
- ② Thrust cover
- ③ Shim
- ④ Bearing
- ⑤ Bush

A	SIDE PLAY: 1.0 mm (0.04 in)
B	SIDE CLEARANCE: 0.2~0.4 mm (0.008~0.016 in)

90 Nm (9.0 m•kg, 65 ft•lb)

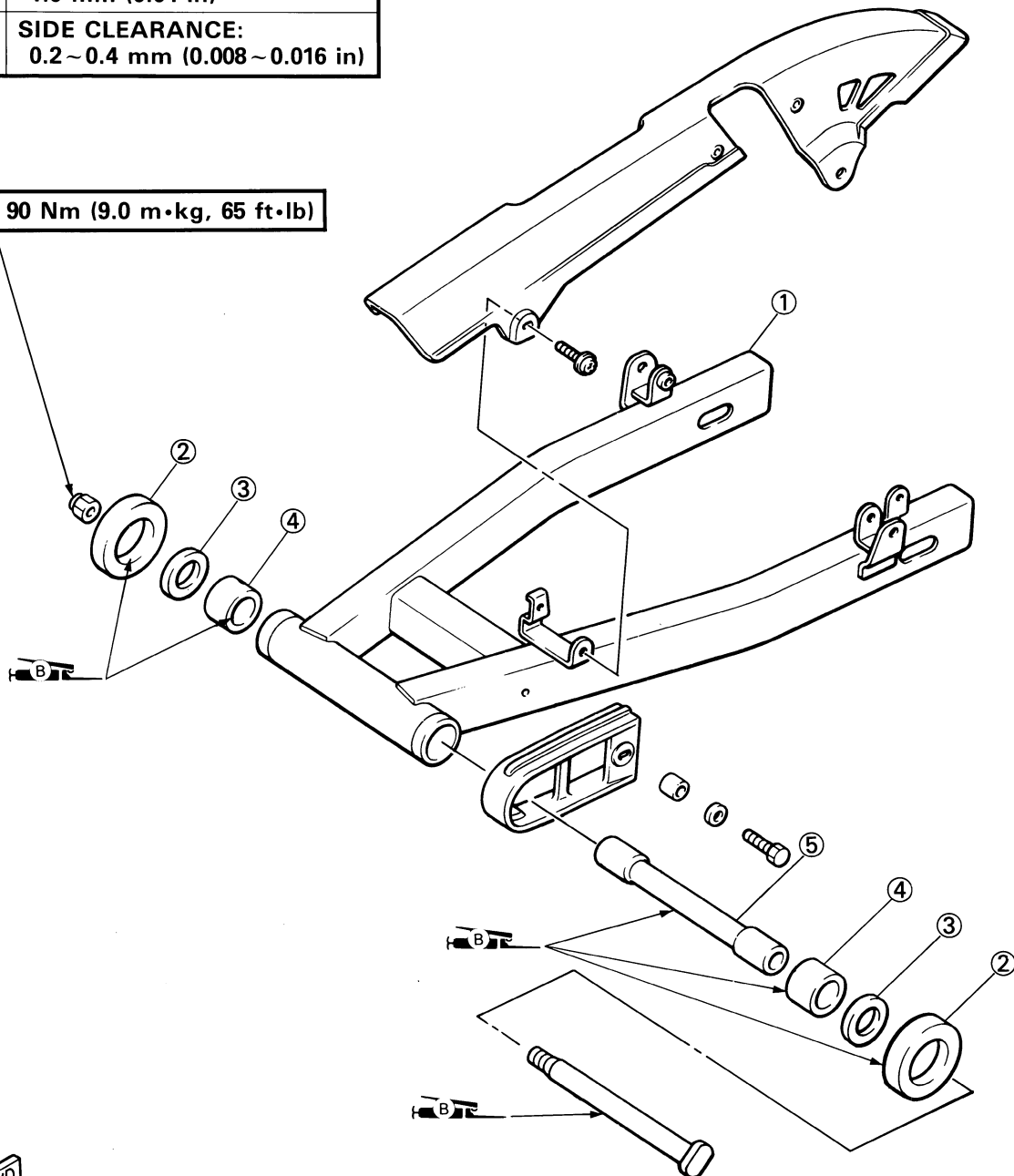



REMOVAL

1. Place the motorcycle on its centerstand.

WARNING:

Support the motorcycle securely so there is no danger of it falling over.

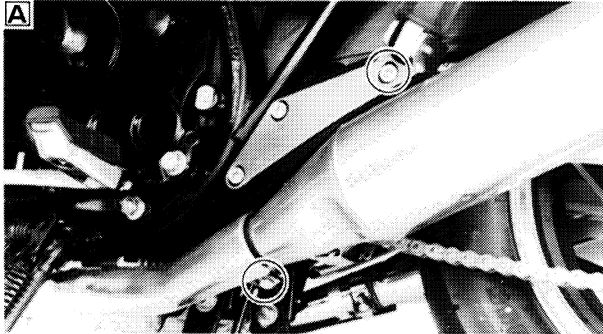

2. Remove:
 - Mufflers

- A** Left side
- B** Right side

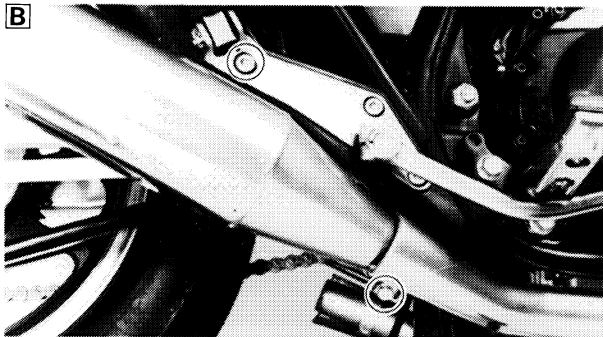

3. Remove:
 - Rear wheel
 Refer to "REAR WHEEL-REMOVAL" section.

5

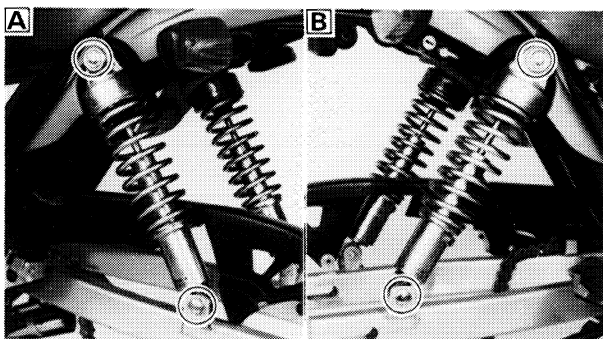

4. Remove:
 - Rear shock absorbers

- A** Left side
- B** Right side

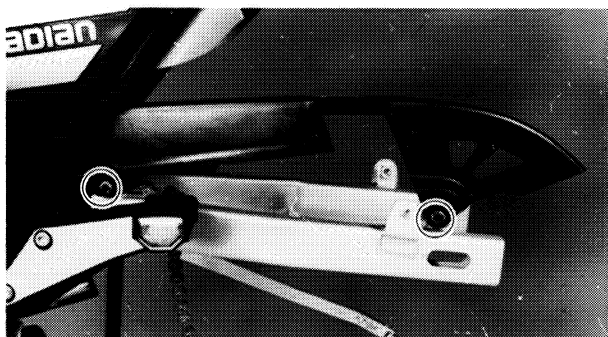

5. Remove:
 - Chain cover



6. Check:
 - Swingarm (Side play)
 - Over specified limit → Inspect bush length and adjust side play using shims.
 - Move swingarm from side to side.



Side Play (At End of Swingarm):
1.0 mm (0.04 in)

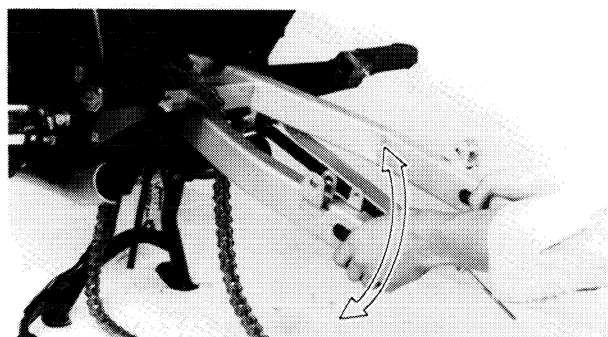

7. Check:
 - Swingarm (Vertical movement)
 - Tightness/Binding/Rough Sports → Replace bearings.
 - Move swingarm up and down.

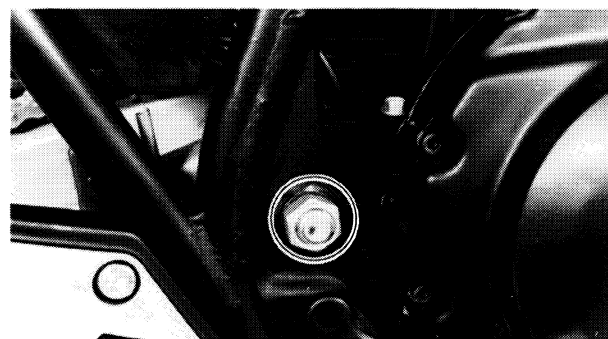

8. Remove:
 - Swingarm

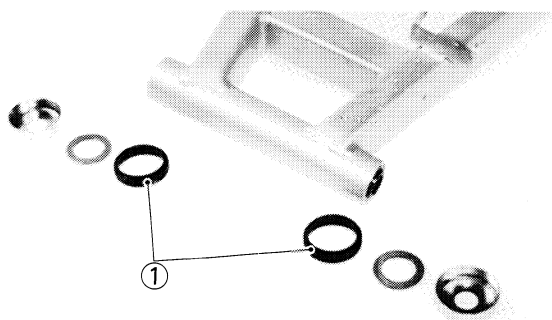

INSPECTION

1. Inspect:
 - Oil seal ①
 - Damage → Replace thrust cover.



ADJUSTMENT

NOTE: _____

When replacing the bush and bearings, note attention to the following points;

- Bearings should be exactly located as shown in the illustration.
- Grease them liberally with wheel bearing grease.

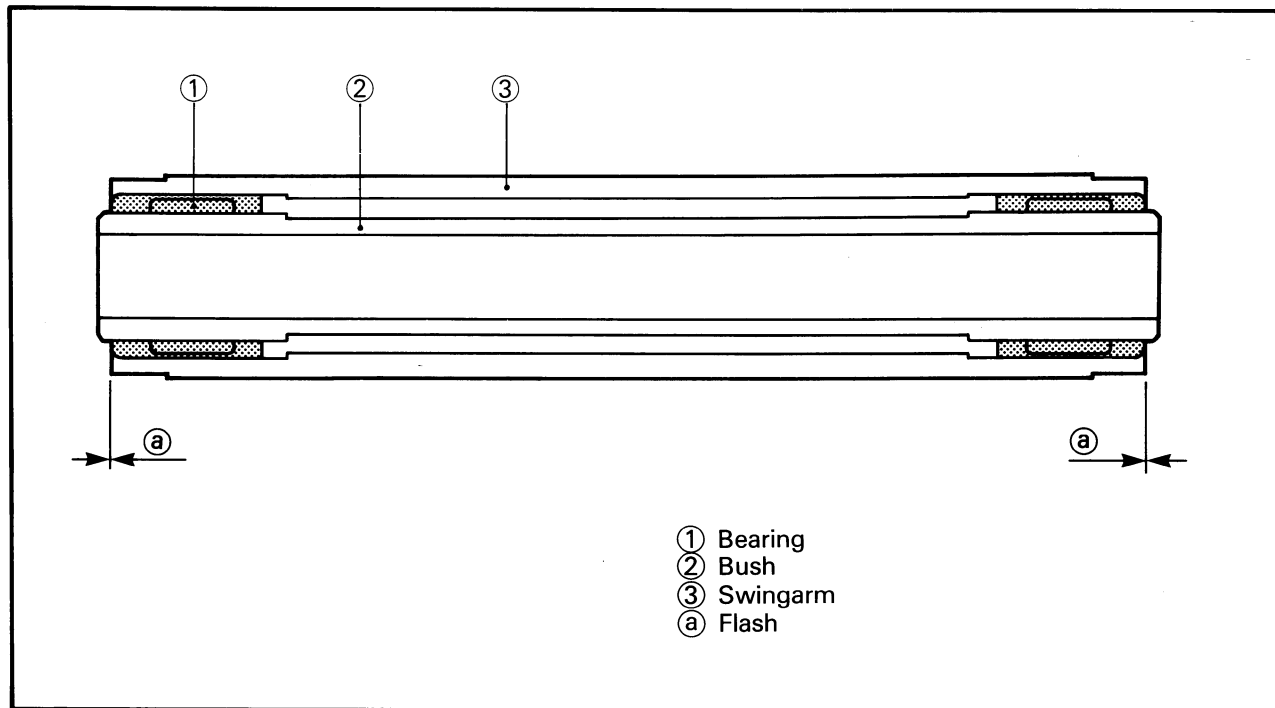

1. Measure:

- Bush length (a)
- Out of specification → Replace bush.

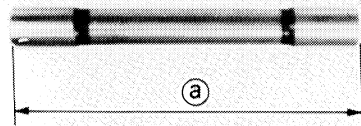

Standard Length:
 197.4 ~ 197.6 mm (7.77 ~ 7.78 in)

2. Measure:

- Swingarm end length (b)

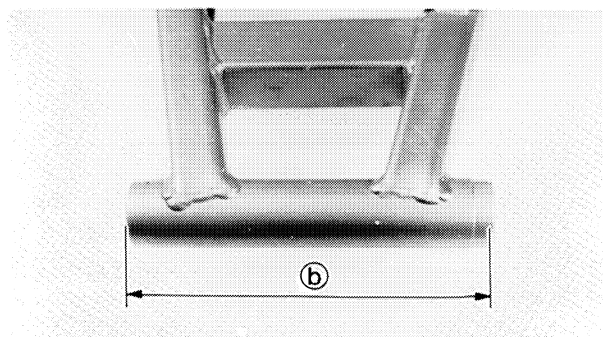



3. Select the proper shim ① thickness to obtain standard swingarm side play (A + B).



Standard Side Play (A + B):
0.2 ~ 0.4 mm (0.008 ~ 0.016 in)



Available Shim Thickness:
1.9 ~ 2.0 mm (0.0748 ~ 0.0787 in)
2.0 ~ 2.1 mm (0.0787 ~ 0.0826 in)
2.1 ~ 2.2 mm (0.0826 ~ 0.0866 in)

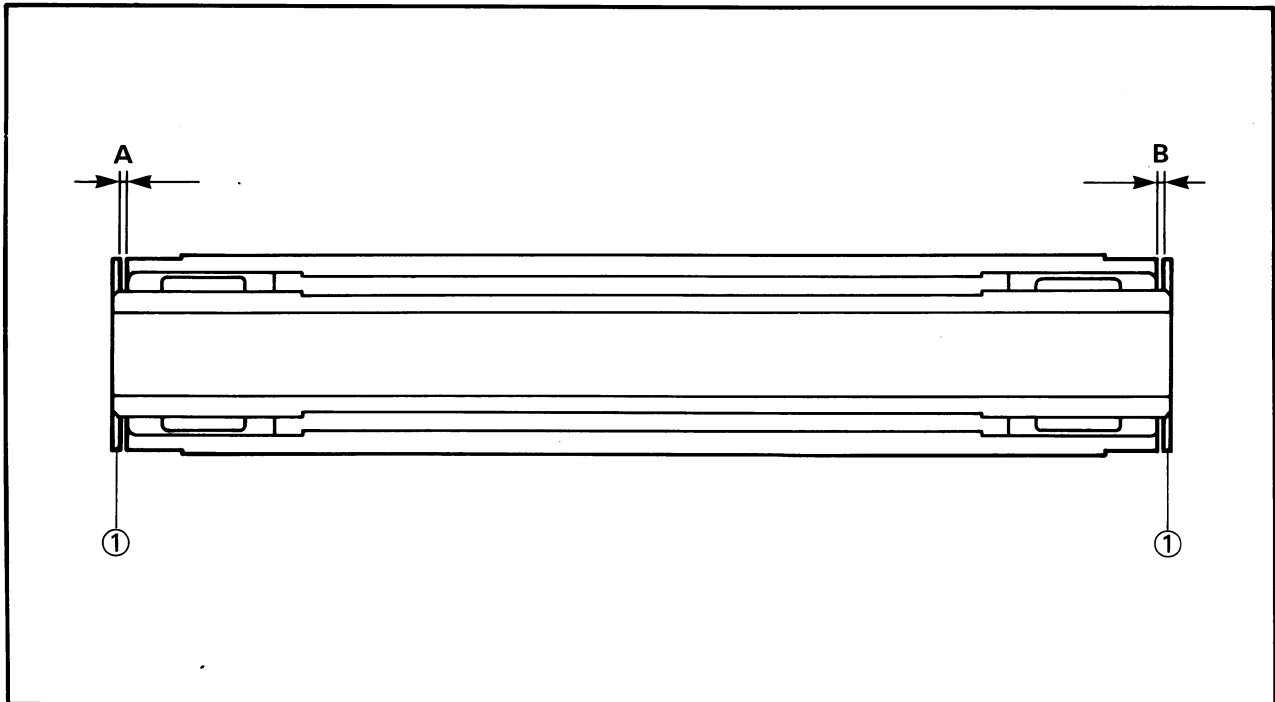

INSTALLATION

Reverse the removal procedure.

Note the following points.

1. Install:
 - Swingarm



Nut (Pivot Shaft):
90 Nm (9.0 m·kg, 56 ft·lb)



2. Install:

- Rear shock absorbers



Bolt (Shock Absorber and Frame):

20 Nm (2.0 m•kg, 14 ft•lb)

Bolt (Shock Absorber and Swingarm):

30 Nm (3.0 m•kg, 22 ft•lb)

3. Install:

- Rear wheel

Refer to "REAR WHEEL-INSTALLATION" section.



Axle Nut:

105 Nm (10.5 m•kg, 75 ft•lb)

4. Install:

- Mufflers



Bolt (Muffler and Footrest Bracket):

25 Nm (2.5 m•kg, 18 ft•lb)



DRIVE CHAIN AND SPROCKETS

REMOVAL

Drive Sprocket

1. Removal:
 - Footrest (Left)
 - Change pedal
 - Drive sprocket cover

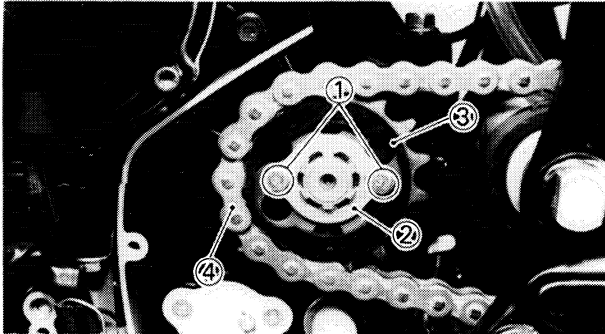

2. Remove:
 - Bolts (drive sprocket) ①
 - Apply the rear brake.
 - Holding plate ②
 - Drive sprocket ③
 - Drive chain ④

Drive Sprocket

1. Remove:
 - Rear wheel
 - Refer to "REAR WHEEL-REMOVAL" section.
2. Remove:
 - Nuts (drive sprocket)
 - Driven sprocket

INSPECTION

Drive Chain

1. Inspect:
 - O-rings
 - Damage/Miss → Replace.
 - Rollers and side plates
 - Damage/Wear → Replace.

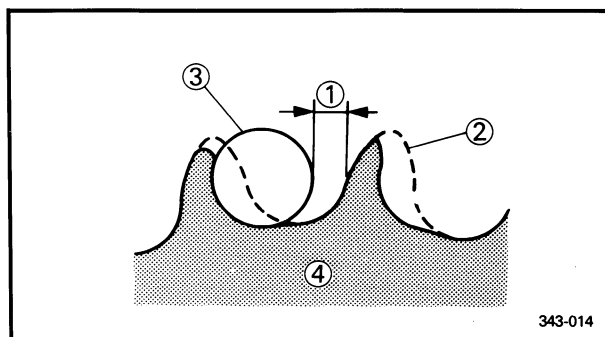

343-014

Drive and Driven Sprockets

1. Inspect:
 - Drive and driven sprockets
 - Wear/Damage → Replace.

- ① 1/4 tooth
- ② Correct
- ③ Roller
- ④ Sprocket

ASSEMBLY

When assembling the sprockets, reverse the removal procedure. Note the following points.

1. Tighten:

- Bolts (drive sprocket)
- Nuts (driven sprocket)



Bolts (Drive Sprocket):

10 Nm (1.0 m•kg, 7.2 ft•lb)

Nuts (Driven Sprocket):

32 Nm (3.2 m•kg, 23 ft•lb)

Apply LOCTITE®.

2. Adjust:

- Drive chain slack
- Rear brake free play

Refer to "CHAPTER 2-DRIVE CHAIN SLACK ADJUSTMENT and BRAKE PEDAL FREE PLAY ADJUSTMENT" section.



Drive Chain Slack:

20 ~ 30 mm (0.8 ~ 1.2 in)

Rear Brake Free Play:

20 ~ 30 mm (0.8 ~ 1.2 in)

CHAS



MEMO



CHAPTER 6 ELECTRICAL

YX600S/SC CIRCUIT DIAGRAM	6-1
ELECTRICAL COMPONENTS	6-3
ELECTRICAL STARTING SYSTEM	6-5
CIRCUIT DIAGRAM	6-5
STARTING CIRCUIT OPERATION	6-7
TROUBLESHOOTING	6-8
STARTER MOTOR	6-18
IGNITION SYSTEM	6-25
CIRCUIT DIAGRAM	6-25
DESCRIPTION	6-27
OPERATION	6-27
PICKUP UNIT	6-27
TROUBLESHOOTING	6-28
CHARGING SYSTEM	6-37
CIRCUIT DIAGRAM	6-37
TROUBLESHOOTING	6-39
LIGHTING SYSTEM	6-45
CIRCUIT DIAGRAM	6-45
TROUBLESHOOTING	6-47
LIGHTING SYSTEM TEST AND CHECKS	6-52
SIGNAL SYSTEM	6-55
CIRCUIT DIAGRAM	6-55
TROUBLESHOOTING	6-57
SIGNAL SYSTEM TEST AND CHECKS	6-61
OIL LEVEL SWITCH TEST	6-64
CARBURETOR AIR VENT SYSTEM	6-65
CIRCUIT DIAGRAM	6-65
DESCRIPTION	6-67
OPERATION	6-67
TROUBLESHOOTING	6-68

ELECTRICAL

YX600S/SC CIRCUIT DIAGRAM

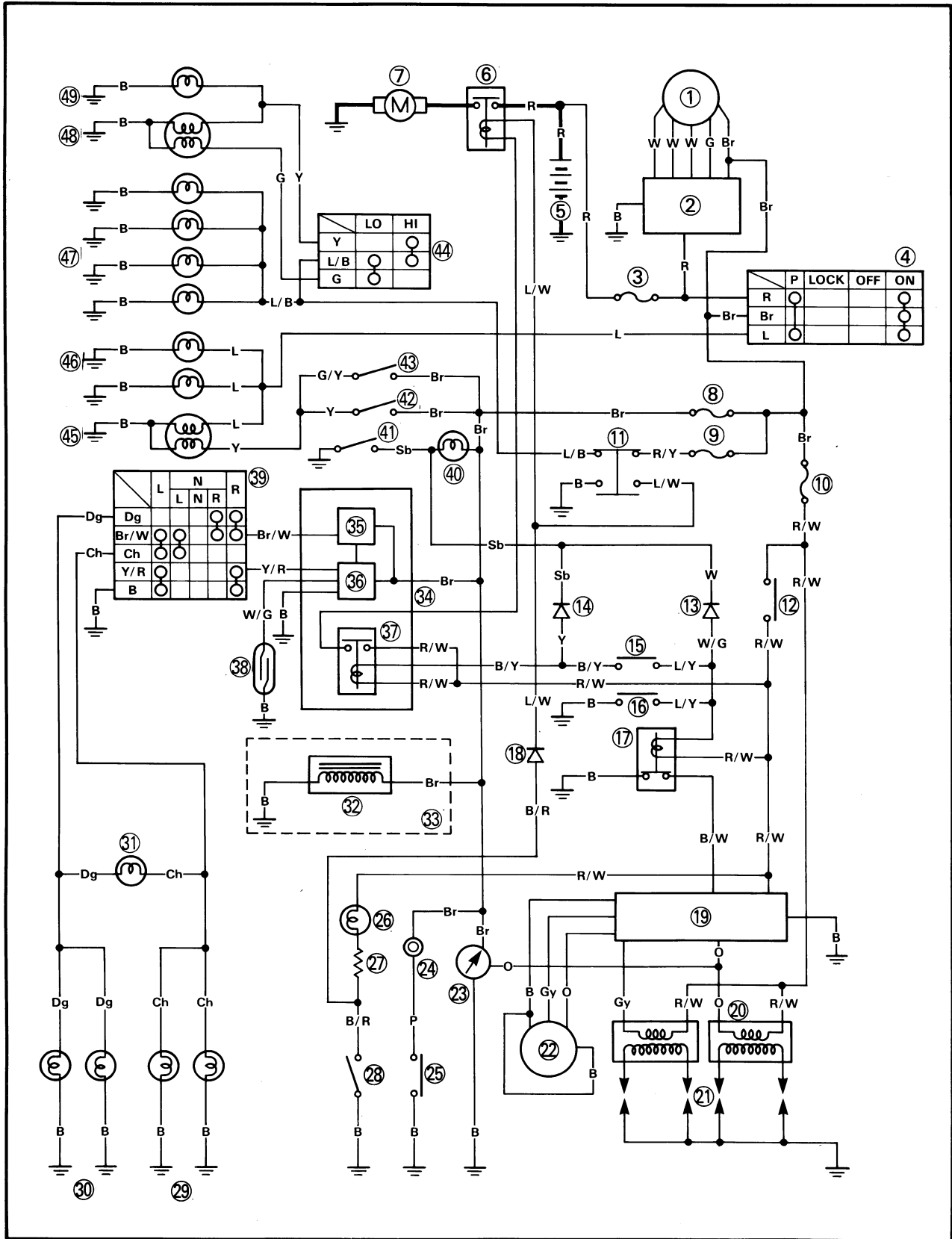



- | | |
|---|--|
| <ul style="list-style-type: none"> ① AC Magneto ② Rectifier/Regulator ③ Fuse (MAIN) ④ Main switch ⑤ Battery ⑥ Starter relay ⑦ Starter motor ⑧ Fuse (SIGNAL) ⑨ Fuse (HEAD) ⑩ Fuse (IGNITION) ⑪ "START" switch ⑫ "ENGINE STOP" switch ⑬ Diode ⑭ Diode ⑮ Clutch switch ⑯ Sidestand switch ⑰ Sidestand relay ⑱ Diode ⑲ Ignitor unit ⑳ Ignition coil ㉑ Spark plug ㉒ Pickup coil ㉓ Tachometer ㉔ Horn ㉕ "HORN" switch | <ul style="list-style-type: none"> ㉖ "OIL" indicator light ㉗ Resistor ㉘ Oil level switch ㉙ Flasher light (Left) ㉚ Flasher light (Right) ㉛ "TURN" indicator light ㉜ Air vent control valve ㉝ California only ㉞ Relay assembly ㉟ Flasher relay
(Included in relay assembly) ㊱ Flasher cancelling unit
(Included in relay assembly) ㊲ Starting circuit cut-off relay
(Included in relay assembly) ㊳ Reed switch ㊴ "TURN" switch ㊵ "NEUTRAL" indicator light ㊶ Neutral switch ㊷ Rear brake switch ㊸ Front brake switch ㊹ "LIGHTS" (Dimmer) switch ㊺ Tail/Brake light ㊻ License light ㊼ Meter light ㊽ Headlight ㊾ "HIGH BEAM" indicator light |
|---|--|

COLOR CODE

O	Orange	Y/R	Yellow/Red
R	Red	Br/W	Brown/White
L	Blue	R/W	Red/White
Br	Brown	R/Y	Red/Yellow
B	Black	B/R	Black/Red
Y	Yellow	B/W	Black/White
W	White	B/Y	Black/Yellow
G	Green	L/W	Blue/White
P	Pink	L/B	Blue/Black
Dg	Dark green	L/Y	Blue/Yellow
Ch	Chocolate	G/Y	Green/Yellow
Gy	Gray	W/R	White/Red
Sb	Sky blue	W/G	White/Green



ELECTRICAL COMPONENTS

- ① Main switch
- ② Sidestand relay
- ③ Relay assembly
- ④ Diode assembly
- ⑤ Rear brake switch
- ⑥ Sidestand switch
- ⑦ Oil level switch
- ⑧ Horn

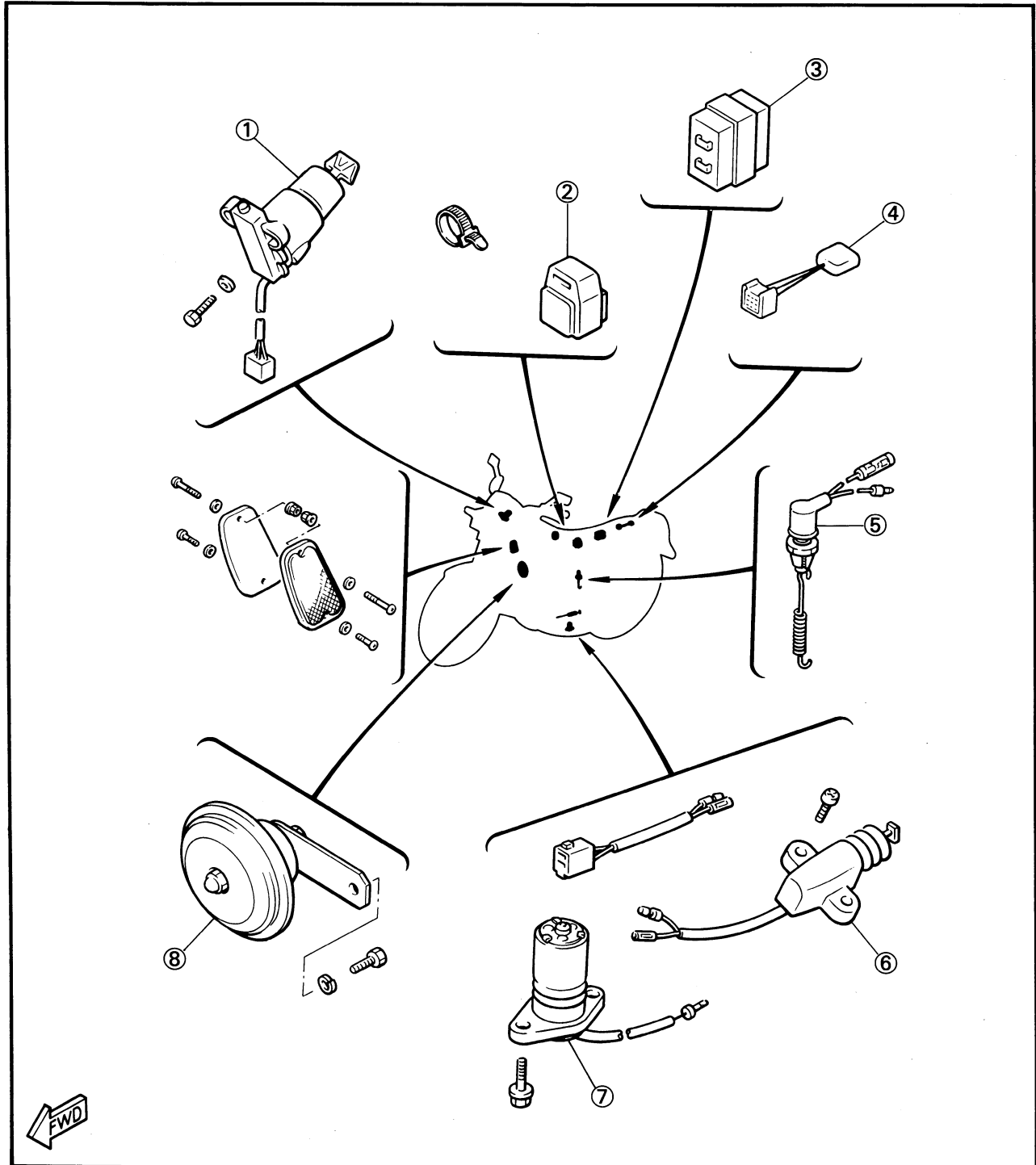



- ① Rectifier/Regulator
- ② Starter relay
- ③ Ignitor unit
- ④ Battery
- ⑤ Ignition coil (For #1, #4 cylinder)
- ⑥ Ignition coil (For #2, #3 cylinder)
- ⑦ Neutral switch

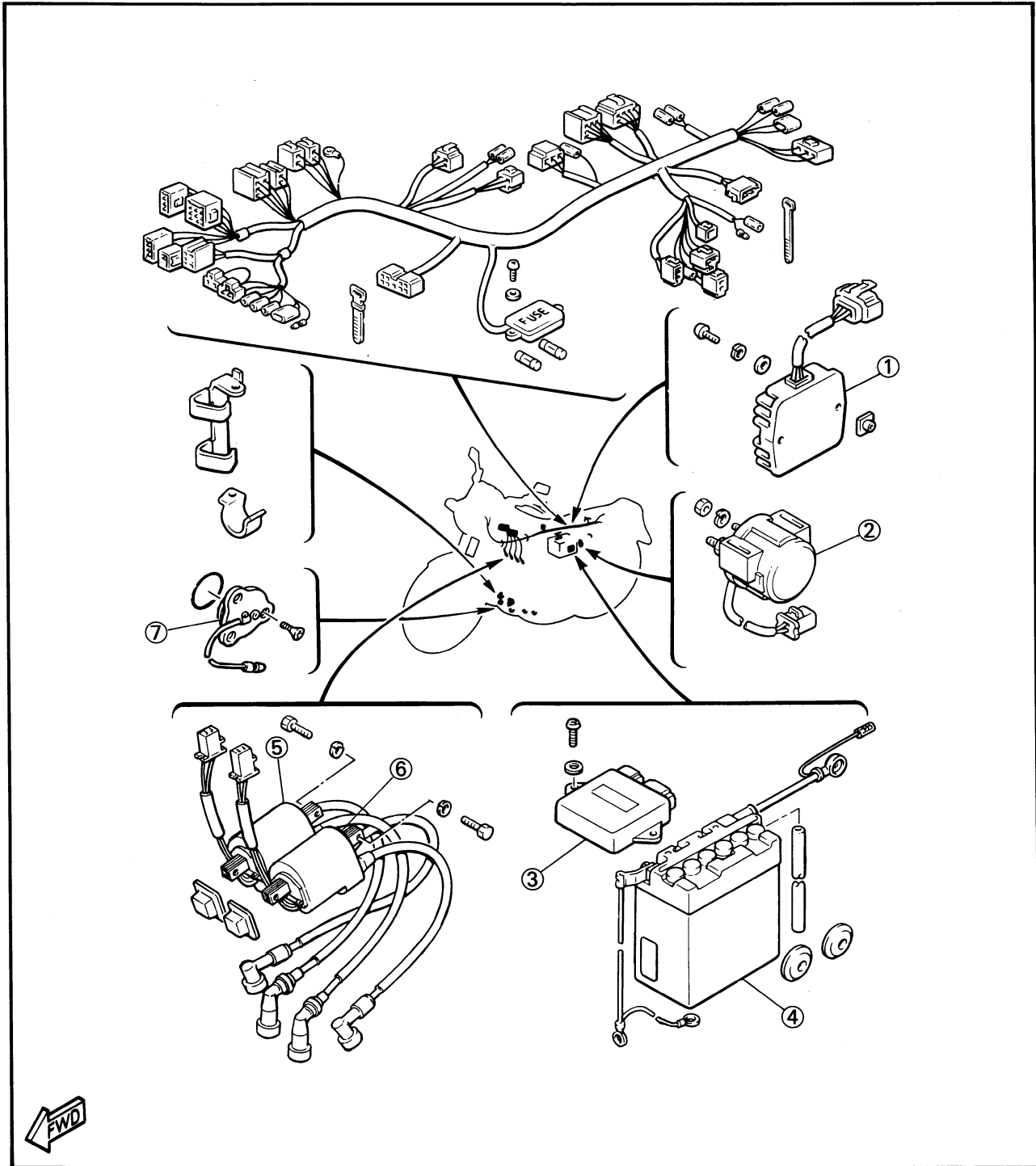

ELECTRICAL STARTING SYSTEM

ELEC



NOTE: _____

For the color codes, see page 6-2.

- ③ Fuse (MAIN)
- ④ Main switch
- ⑤ Battery
- ⑥ Starter relay
- ⑦ Starter motor
- ⑩ Fuse (IGNITION)
- ⑪ "START" switch
- ⑫ "ENGINE STOP" switch
- ⑬ Diode
- ⑭ Diode
- ⑮ Clutch switch
- ⑯ Sidestand switch
- ⑰ Starting circuit cut off relay (Included in relay assembly)
- ⑱ Neutral switch

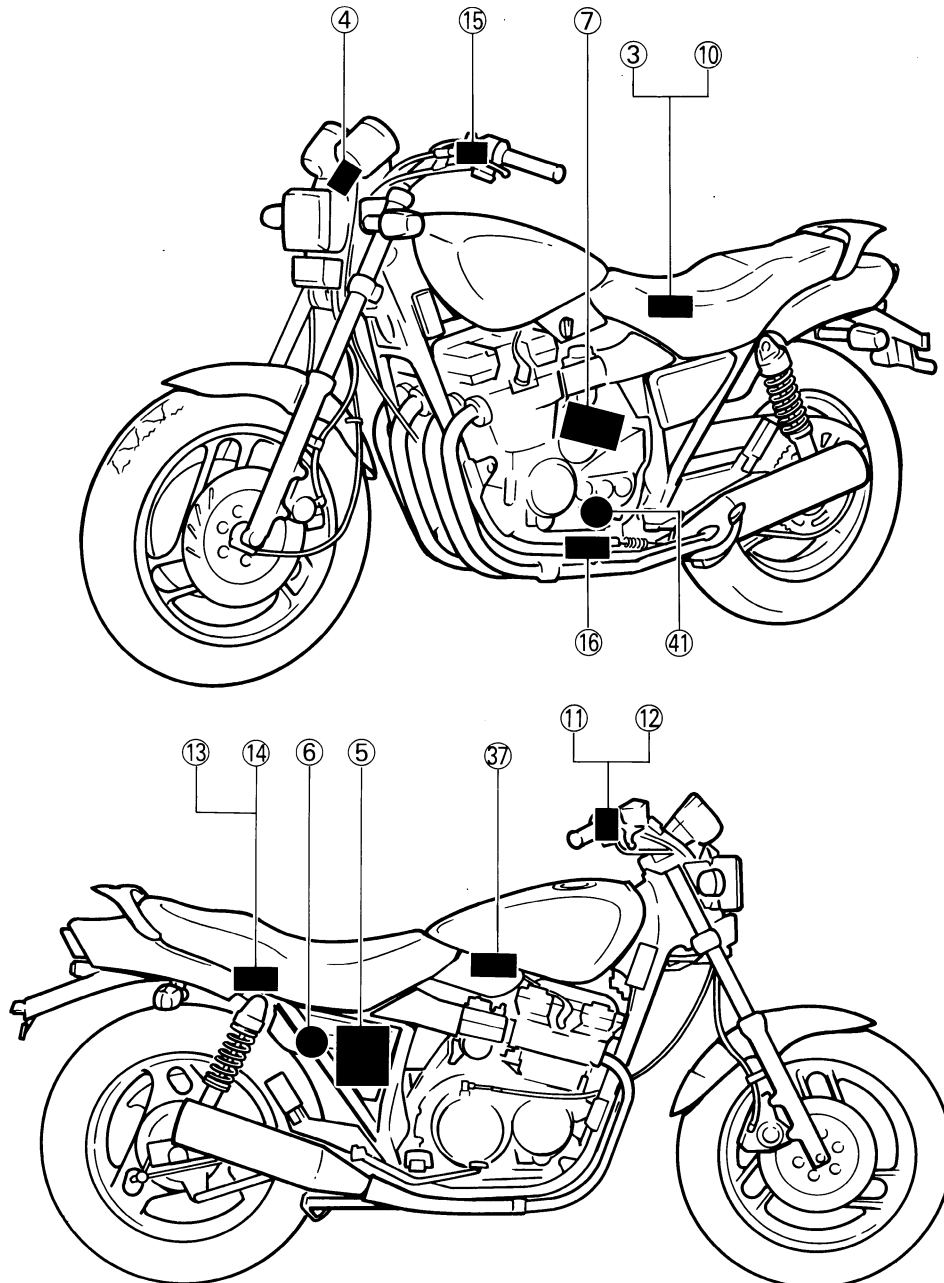

6



STARTING CIRCUIT OPERATION

The starting circuit on this model consists of the starter motor, starter relay, starting circuit cut-off relay, and sidestand relay.

If the engine stop switch and the main switch are both on, the starter motor can operate only if:

- The transmission is in neutral (the neutral switch is on).
- The sidestand is up (the sidestand switch is on) and clutch lever is pulled in (clutch switch is on).

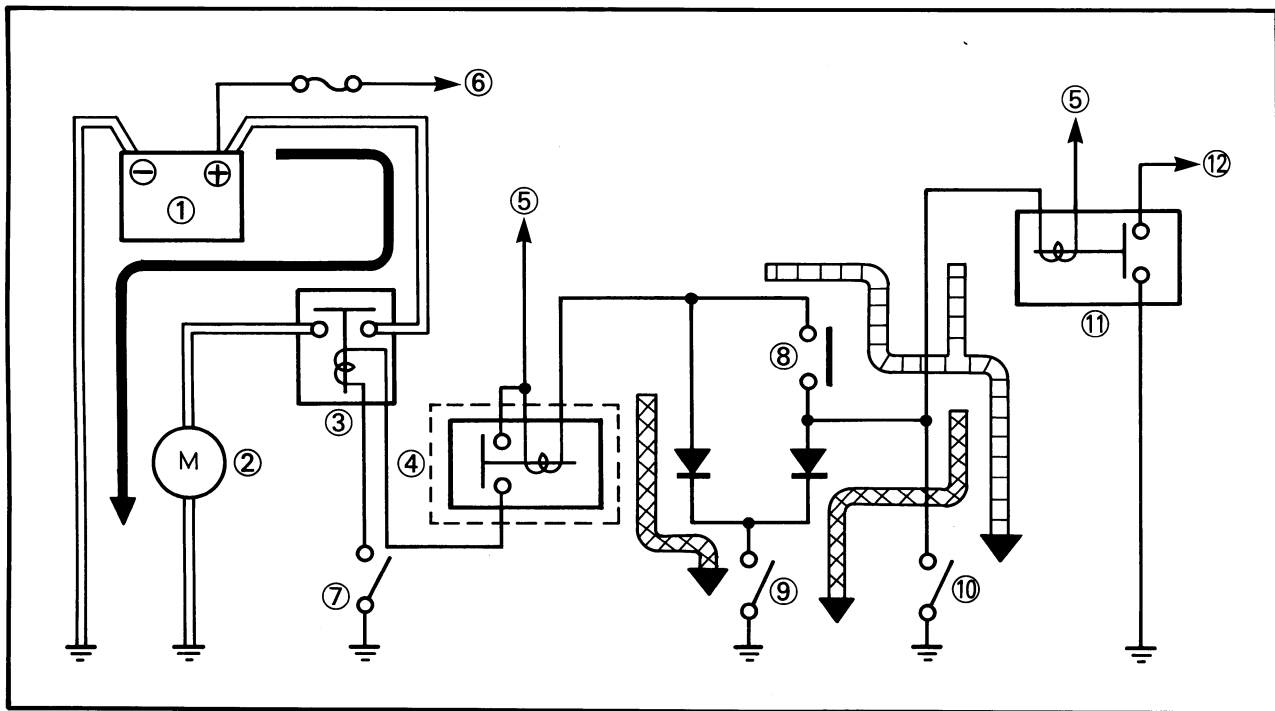
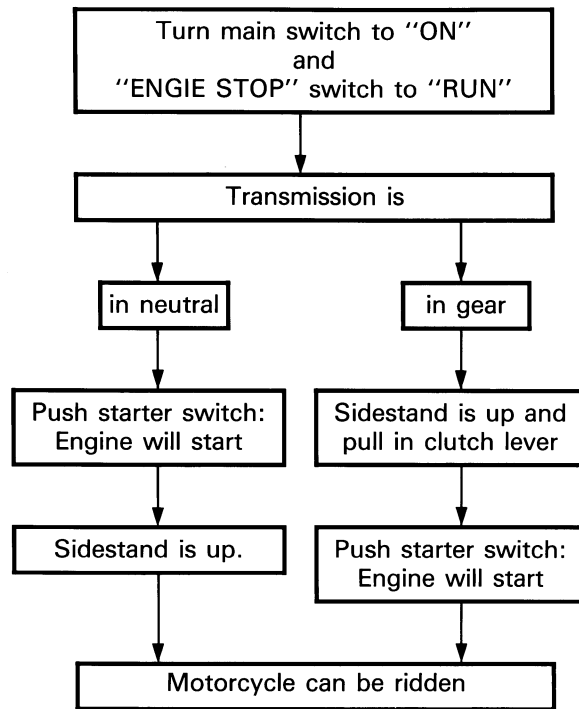

- ① Battery
- ② Starter motor
- ③ Starter relay
- ④ Starting circuit cut-off relay
- ⑤ To "ENGINE STOP" switch
- ⑥ To main switch
- ⑦ "START" switch
- ⑧ Clutch switch
- ⑨ Neutral switch
- ⑩ Sidestand switch
- ⑪ Sidestand relay
- ⑫ To ignitor unit

← [Symbol: hatched rectangle] WHEN THE TRANSMISSION IS IN NEUTRAL.

← [Symbol: solid rectangle] WHEN THE SIDESTAND IS UP AND CLUTCH LEVER IS PULLED IN.



TROUBLESHOOTING

STARTER MOTOR DOES NOT OPERATE.

Before this troubleshooting, remove following parts.

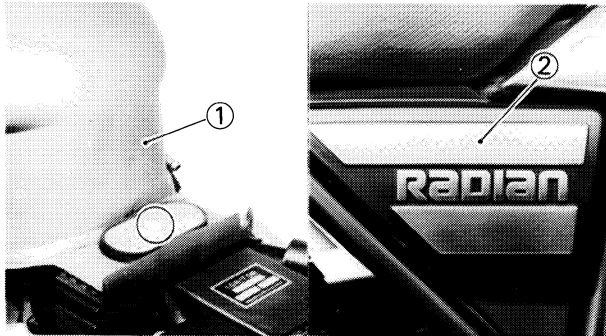

- Seat ①
- Fuel tank ①
- Side cover (Right) ②
- Headlight lens unit ③
- Cover (Front) ④

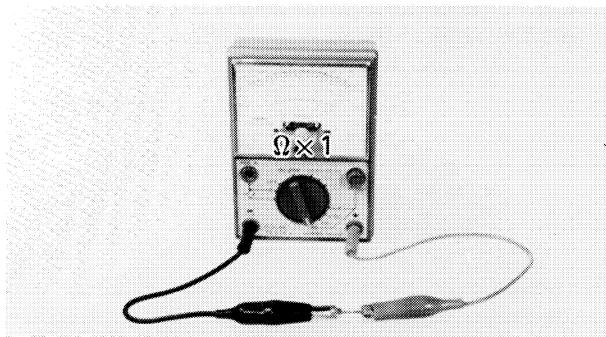
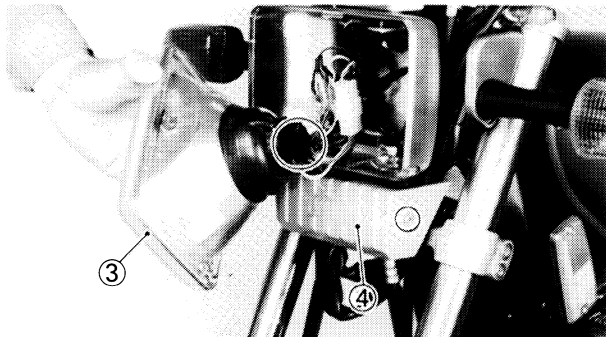

1. Fuse inspection

- Remove fuse (MAIN) and fuse (IGNITION).
- Connect Pocket Tester (YU-03112) to fuse and check it for continuity.

NOTE:

Set tester selector to " $\Omega \times 1$ " position.

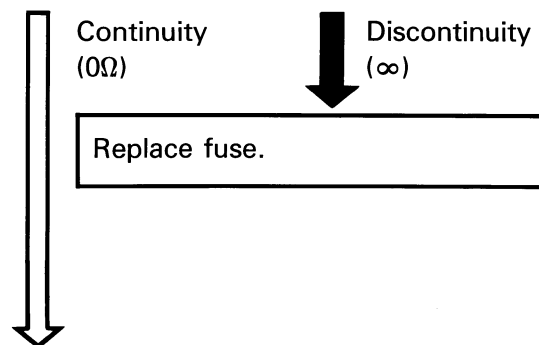

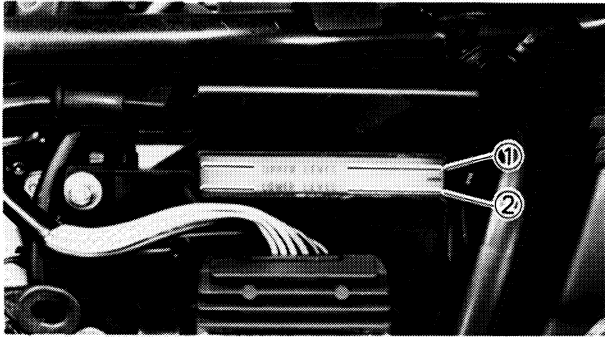

2. Battery fluid level inspection
 - Fluid level should be between upper ① and lower ② level mark.

Correct ↓ Incorrect

- Refill battery fluid.

CAUTION: _____

Refill with distilled water only; tap water contains minerals harmful to a battery.



3. Battery terminal inspection
 - Inspect battery terminal and connections.

OK ↓ Dirty or poor connection

- Clean battery terminals using wire brush.

NOTE: _____

After cleaning terminals, apply grease lightly to both terminals.

- Connect battery leads correctly.

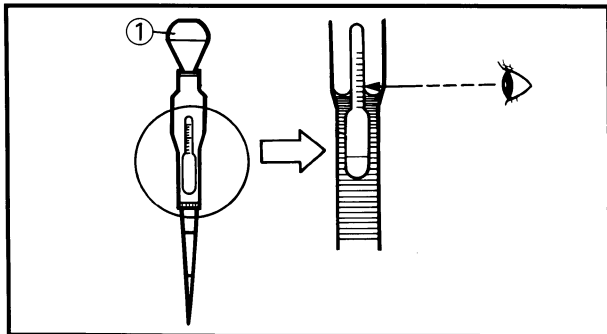

4. Battery fluid specific gravity inspection
 - Remove caps.
 - Inspect specific gravity of all cell using Battery Hydrometer ①.

Specific Gravity:
 1.280 ± 0.01 at 20°C (68°F)

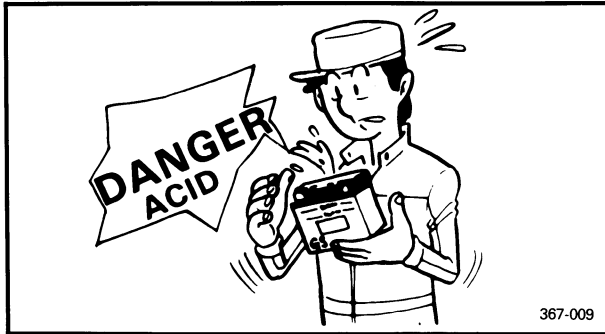

WARNING:

Battery electrolyte is poisonous and dangerous, causing severe burns, etc. It contains sulfuric acid. Avoid contact with skin, eyes or clothing. Antidote: **EXTERNAL**-Flush with water. **INTERNAL**-Drink large quantities of water or milk. Follow with milk of magnesia, beaten egg, or vegetable oil. Call a physician immediately.

Eyes: Flush with water for 15 minutes and get prompt medical attention. Batteries produce explosive gases. Keep sparks, flame, cigarettes etc., away. Ventilate when charging or using in an enclosed space. Always shield your eyes when working near batteries.

KEEP OUT OF REACH OF CHILDREN.

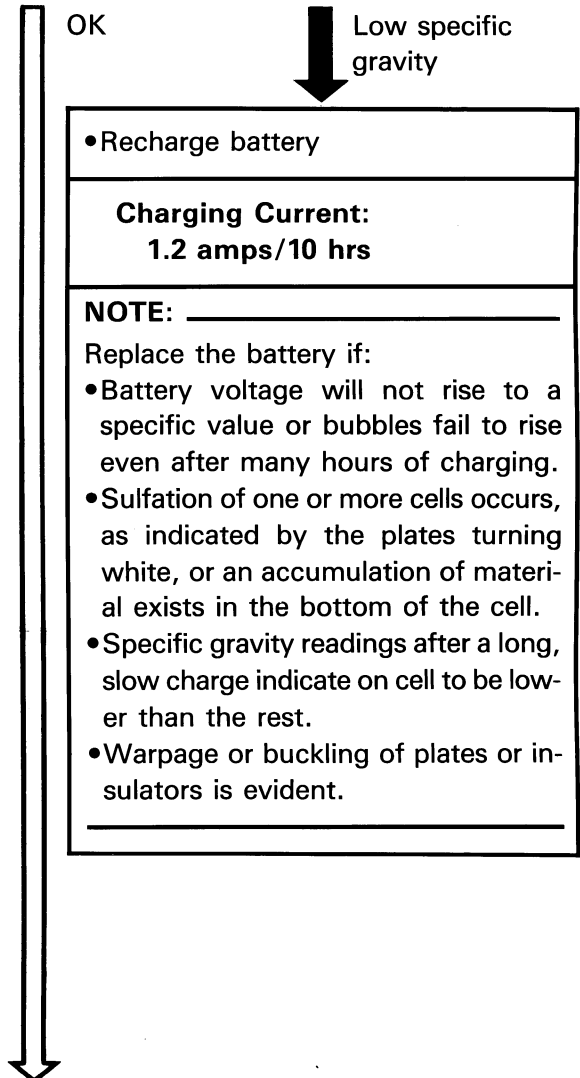

OK

Low specific gravity

<ul style="list-style-type: none"> •Recharge battery
<p>Charging Current: 1.2 amps/10 hrs</p>
<p>NOTE: _____</p> <p>Replace the battery if:</p> <ul style="list-style-type: none"> •Battery voltage will not rise to a specific value or bubbles fail to rise even after many hours of charging. •Sulfation of one or more cells occurs, as indicated by the plates turning white, or an accumulation of material exists in the bottom of the cell. •Specific gravity readings after a long, slow charge indicate on cell to be lower than the rest. •Warping or buckling of plates or insulators is evident.

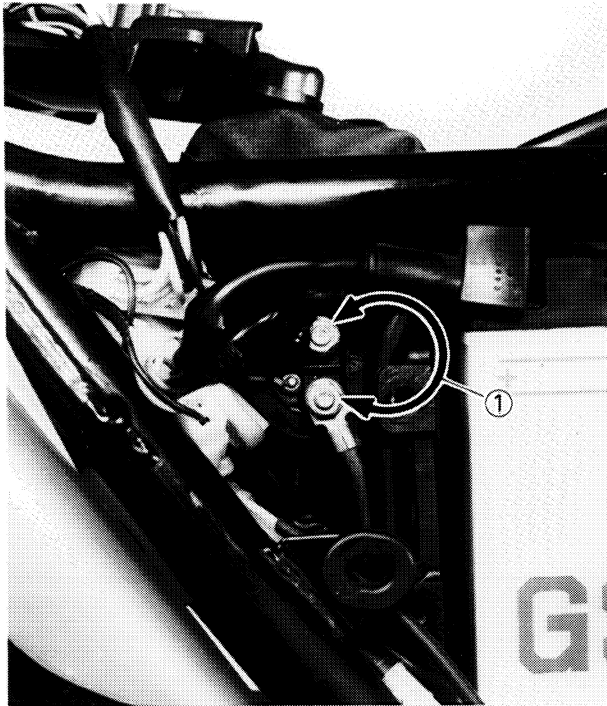

5. Connect battery positive (+) lead and starter motor lead; use heavy duty jumper lead ①.

WARNING:

This test should be performed within a few seconds to prevent further damage. Also, there should be no flammables close to the starter relay.

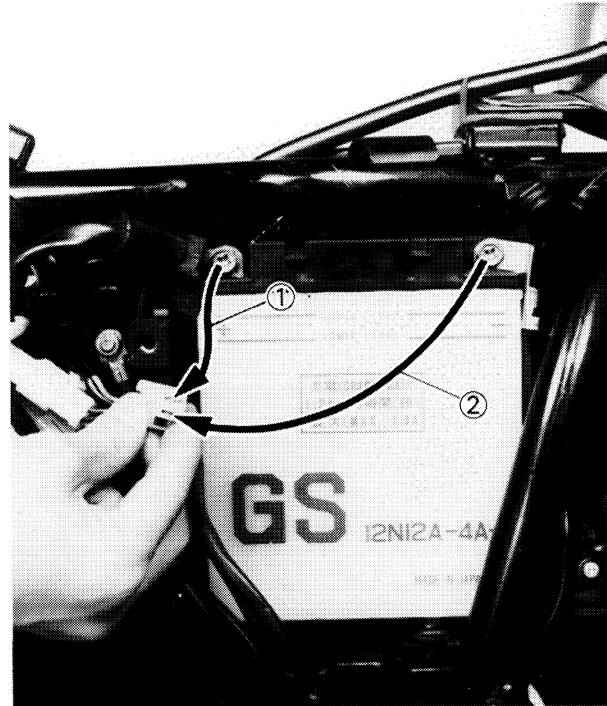
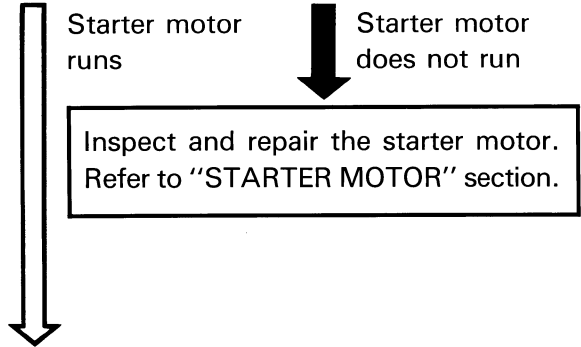

6. Starter relay conduct check
 • Disconnect starter relay leads (Blue/White, Red/White) and connect them to battery positive and negative lead use a jumper leads.

- ① Positive lead
- ② Negative lead

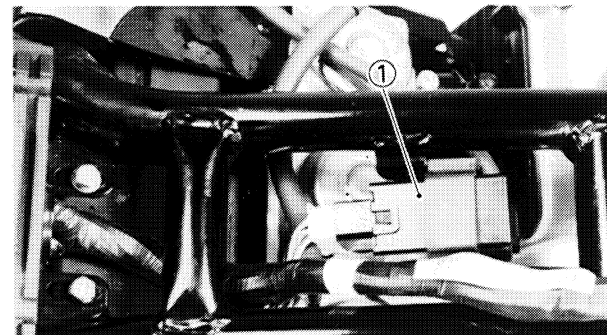
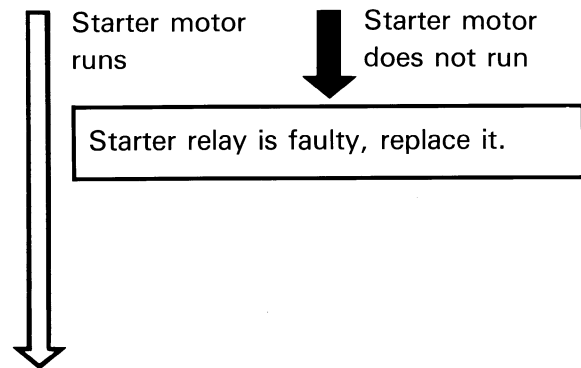

7. Starting circuit cut-off relay conduct check
 • Remove relay assembly ①.

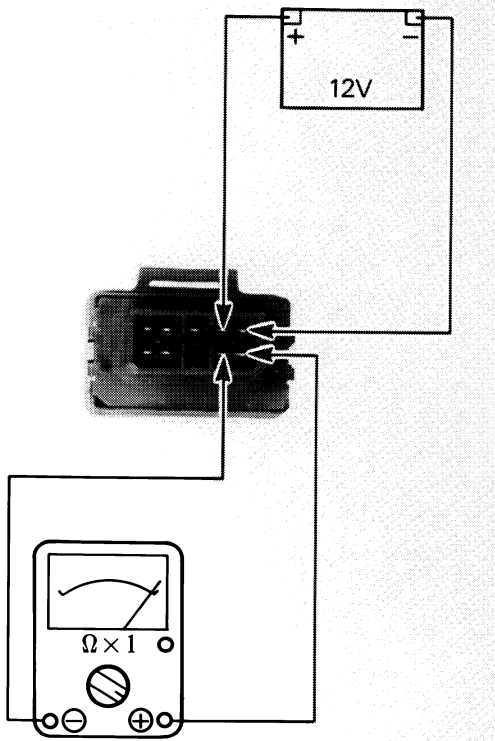

- Connect 12V battery and Pocket Tester (YU-03112) to starting circuit cut-off relay terminals as shows.

NOTE: _____

- Use full charge battery.
- Set tester selector to "Ω × 1" position.

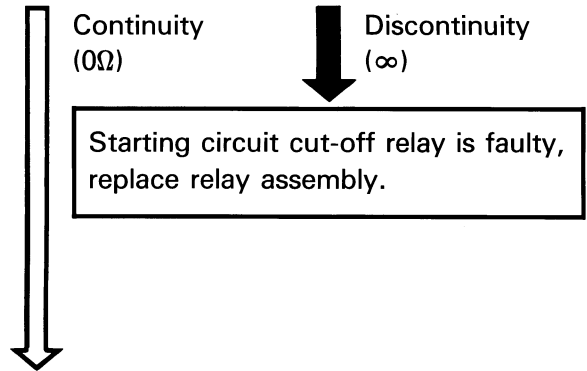

8. Diode assembly condition check
- Remove diode assembly ①.

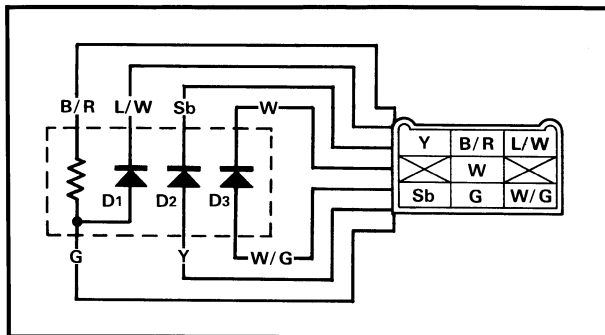
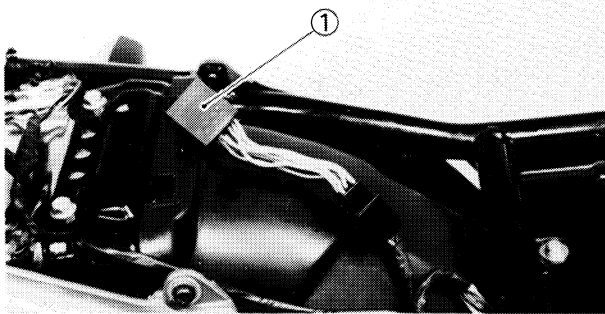

- Connect Pocket Tester (YU-03112) to diode assembly terminals and check diode D₂ and D₃ condition. Refer to following table.

NOTE: _____

Set tester selector to "Ω × 1" position.

Element	Pocket tester		Good
	(+)	(-)	
D ₂	Y	Sb	○
	Sb	Y	×
D ₃	W/G	W	○
	W	W/G	×

○: Continuity (0Ω)
 ×: Discontinuity (∞)

NOTE: _____
 The results "○" or "×" should be reversed according to the pocket tester polarity.

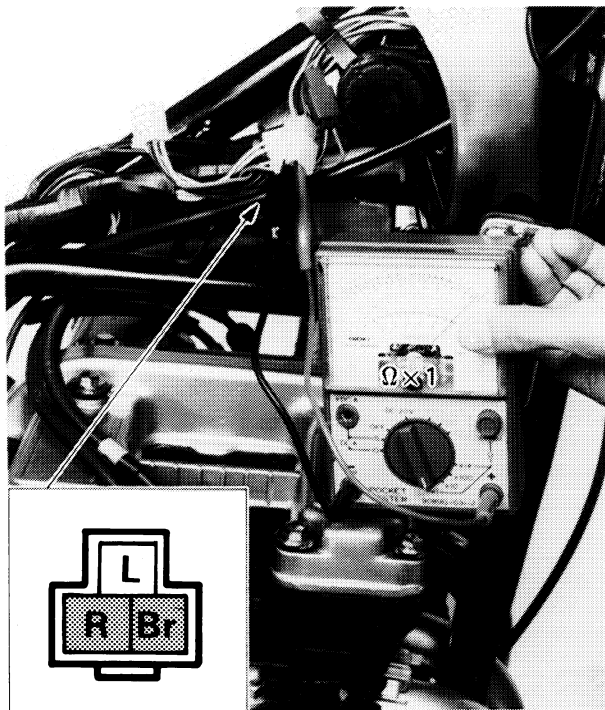
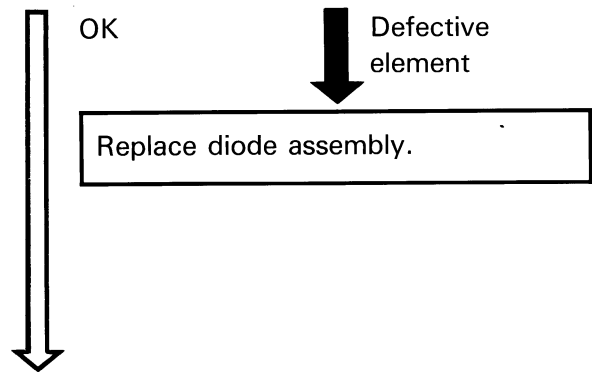

9. Main switch conduct check
- Disconnect main switch coupler (Brown, Red, Blue).
 - Connect Pocket Tester (YU-03112) to main switch leads (Brown, Red).

Tester (+) lead → Red lead
Tester (-) lead → Brown lead

NOTE: _____
 Set tester selector to "Ω × 1" position.

- Turn main switch to "ON" position and check it for continuity.

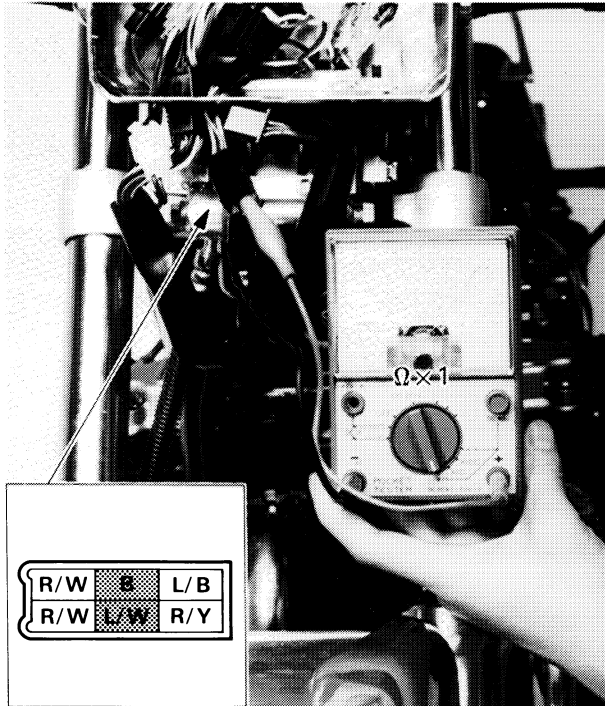
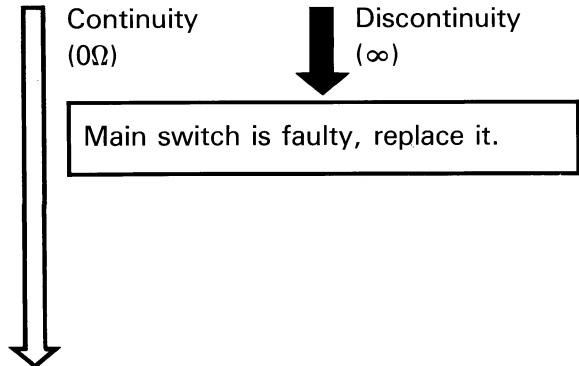

10. "START" switch conduct check

- Disconnect handlebar switch (Right) leads (Red/White, Red/White, Red/Yellow, Blue/Black, Blue/White, Black).
- Connect Pocket Tester (YU-03112) to handlebar switch leads (Blue/White, Black).

Tester (+) lead → Blue/White lead
 Tester (-) lead → Black lead

NOTE: _____
 Set tester selector to "Ω × 1" position.

- Push on "START" switch and check it for continuity.

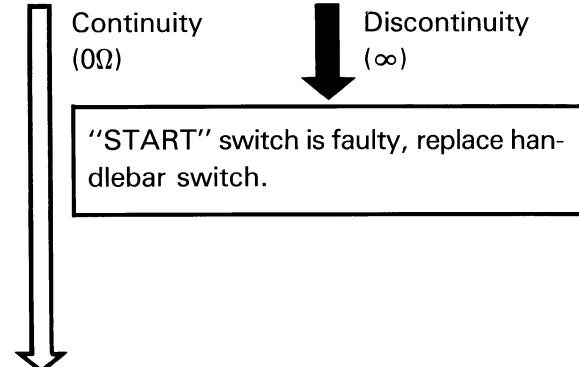
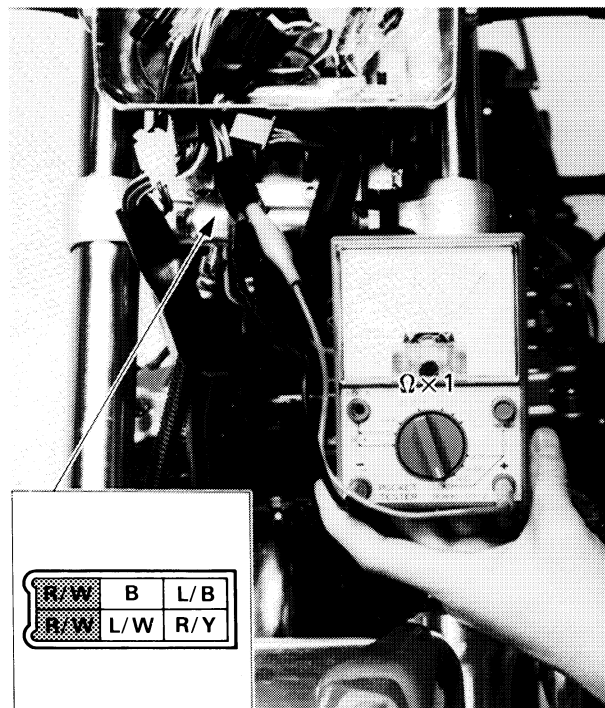

11. "ENGINE STOP" switch conduct check

- Disconnect handlebar switch (Right) leads (Red/White, Red/White, Red/Yellow, Blue/Black, Blue/White, Black).
- Connect Pocket Tester (YU-03112) to handlebar switch leads (Red/White, Red/White).



Tester (+) lead → Red/White lead
Tester (-) lead → Red/White lead

NOTE: _____
 Set tester selector to " $\Omega \times 1$ " position.

- Turn "ENGINE STOP" switch to "RUN" position.

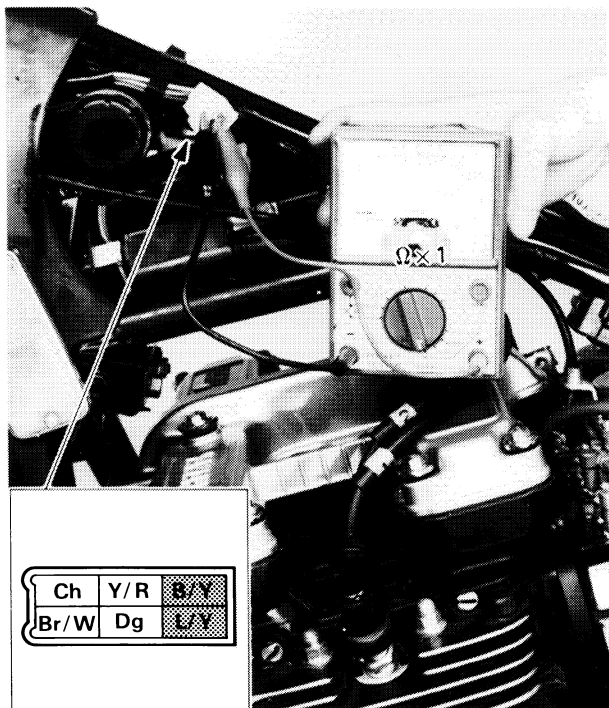
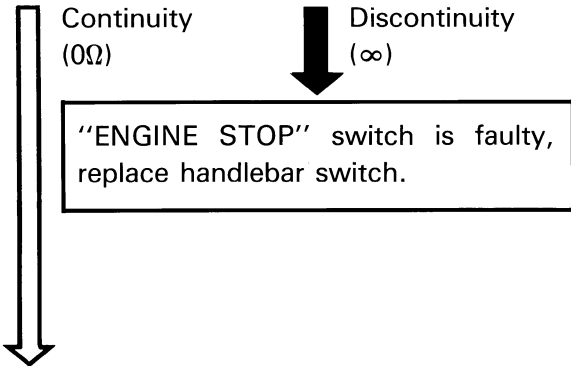

12. Clutch switch conduct check
- Disconnect handlebar switch (Left) leads (Chocolate, Yellow/Red, Black/Yellow, Brown/White, Dark Green, Blue/Yellow).
 - Connect Pocket Tester (YU-03112) to clutch switch leads (Black/Yellow, Blue/Yellow).

Tester (+) lead → Black/Yellow lead
Tester (-) lead → Blue/Yellow lead

NOTE: _____
 Set tester selector to " $\Omega \times 1$ " position.

- Clutch lever is pulled and check clutch switch for continuity.

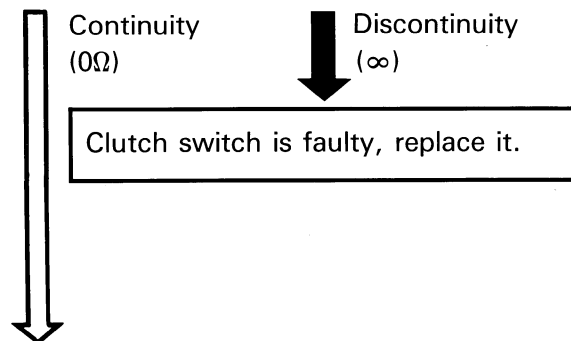

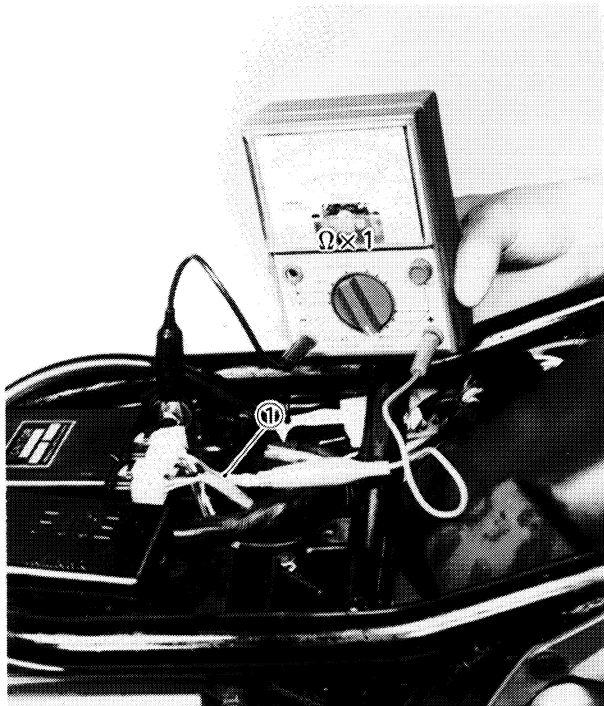

13. Neutral switch conduct check

- Disconnect neutral switch lead (Sky blue) ①.
- Connect Pocket Tester (YU-03112) to neutral switch lead and frame earth lead.

Tester (+) lead → Sky blue lead
Tester (-) lead → Frame earth

NOTE: _____

Set tester selector to “Ω × 1” position.

- Transmission is in neutral and check neutral switch for continuity.

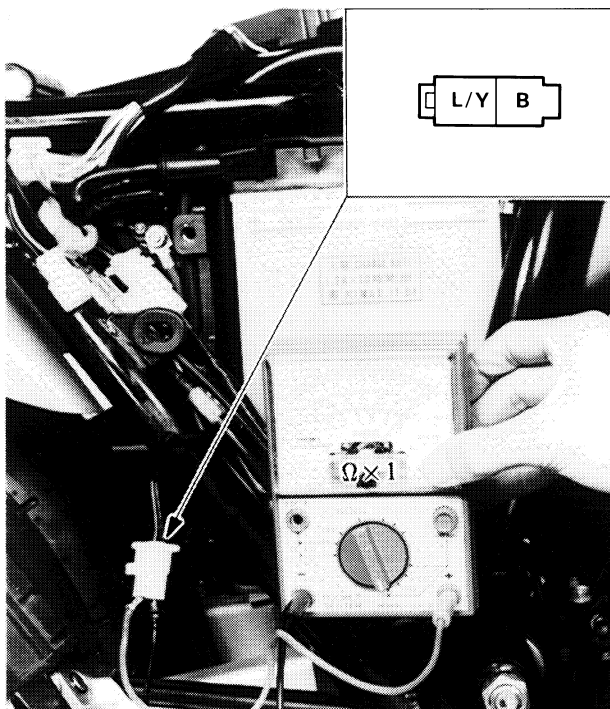
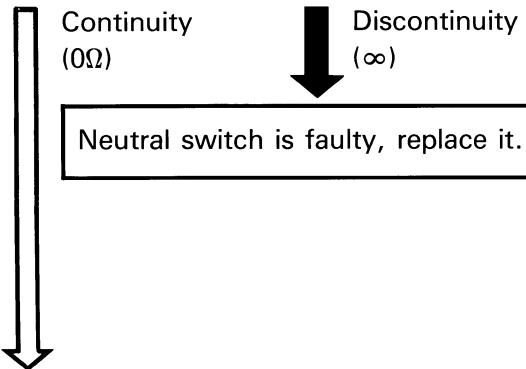

14. Sidestand switch conduct check

- Disconnect sidestand leads (Blue/Yellow, Black).
- Connect Pocket Tester (YU-03112) to sidestand switch leads.

Tester (+) lead → Blue/Yellow lead
Tester (-) lead → Black lead

NOTE: _____

Set tester selector to “Ω × 1” position.

- Place motorcycle on centerstand.
- Sidestand is up and check sidestand switch for continuity.

ELECTRICAL STARTING SYSTEM

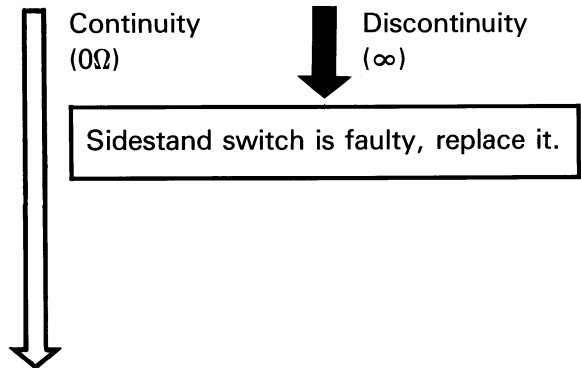

15. Check entire electrical starting system for connections. Refer to "WIRING DIAGRAM" section.

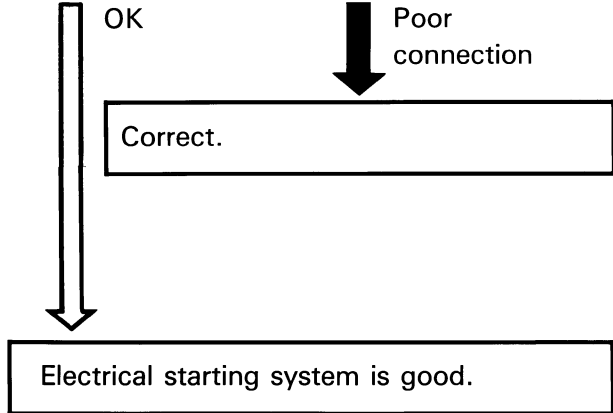

Electrical starting system is good.



STARTER MOTOR

- ① O-ring
- ② Gear assembly
- ③ Shims
- ④ Armature coil assembly
- ⑤ Starter motor lead
- ⑥ Yoke assembly
- ⑦ Brush assembly

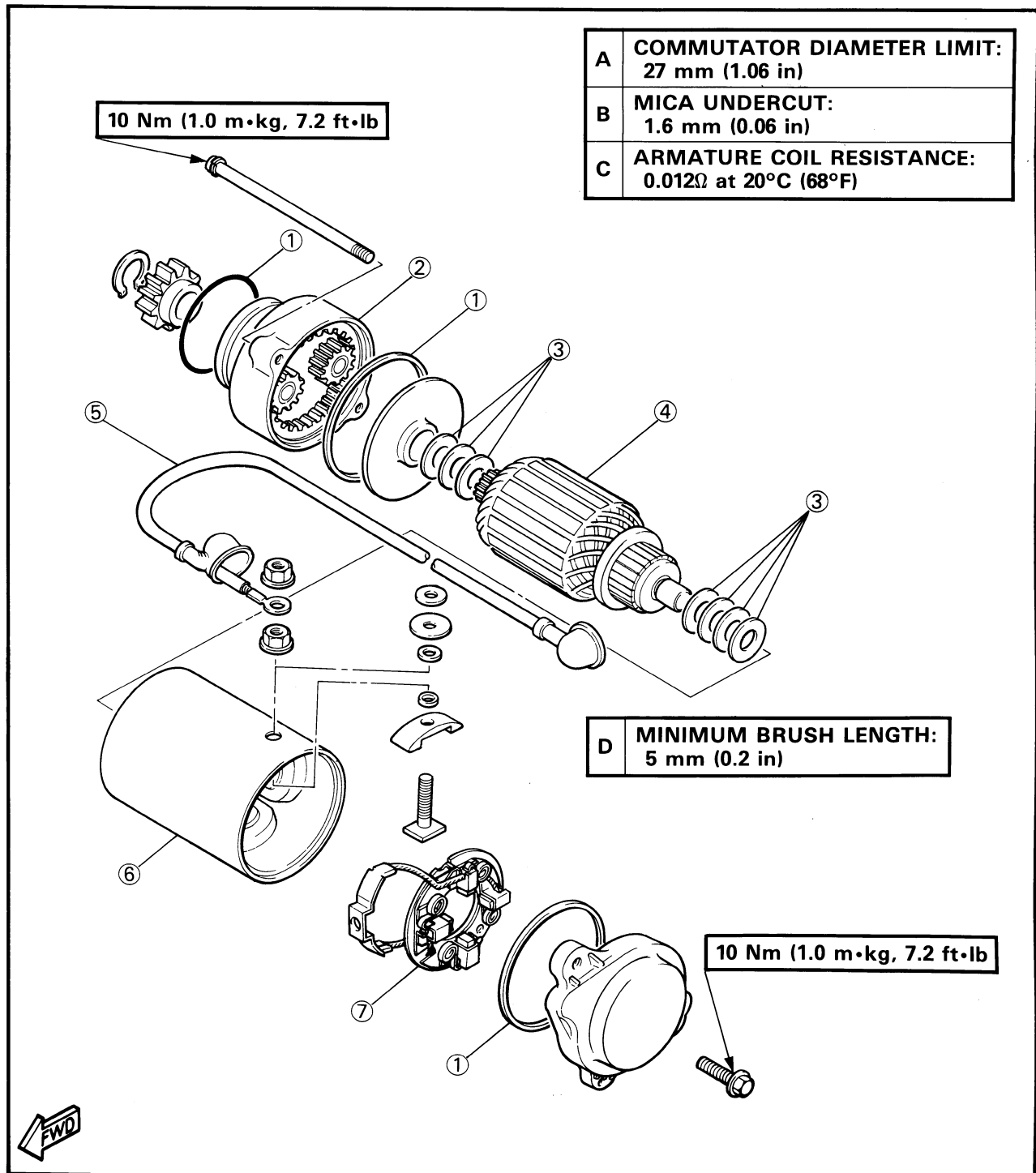

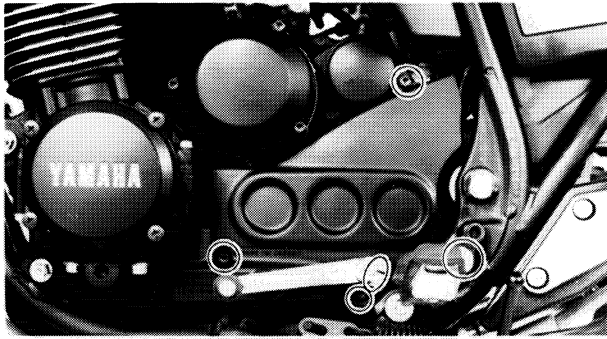
**Removal**

1. Remove:
 - Footrest (Left)
 - Change pedal
 - Cover (Drive sprocket)



2. Remove:
 - Starter motor lead

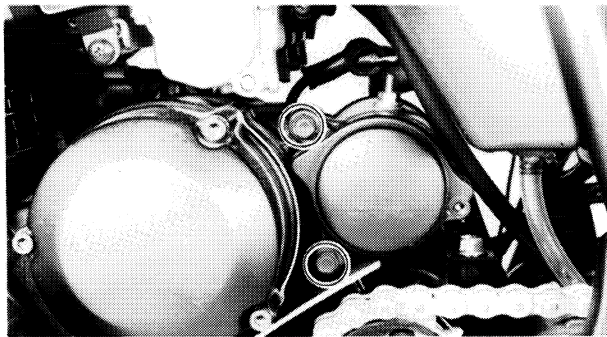

3. Remove:
 - Starter motor

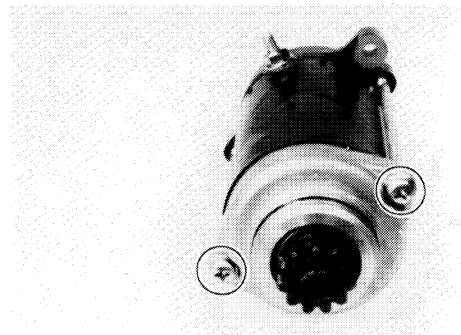
**Disassembly**

1. Remove:
 - Screws

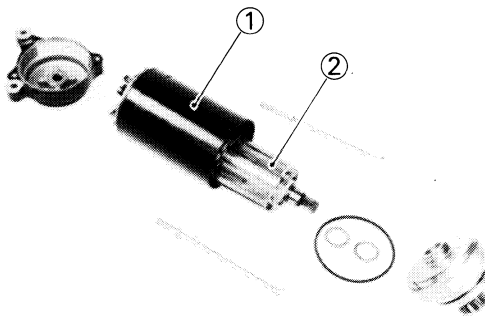

2. Remove:
 - Yoke assembly ①
 - Armature coil assembly ②

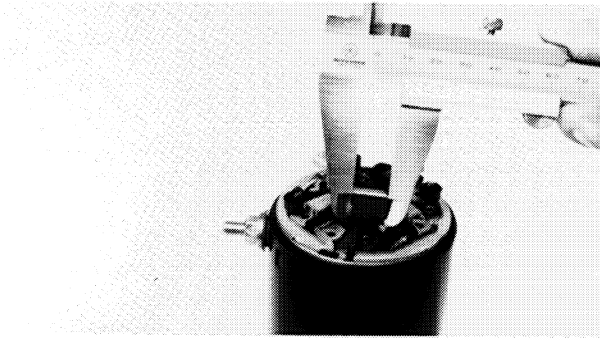

Inspection and Repair

1. Measure:

- Brush length (each)
Out of specification → Replace brush.



Minimum Brush Length:
5 mm (0.2 in)

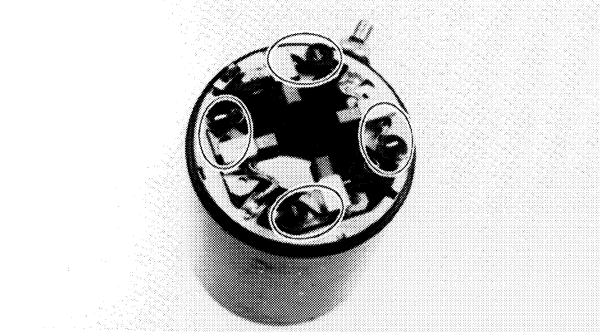

2. Inspect:

- Brush spring
Damage → Replace.

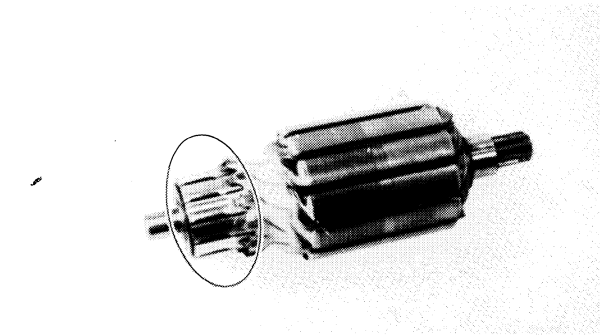

3. Inspect:

- Commutator (Outer surface)
Grooved wear/Burning/Scratches →
Smooth out using a sandpaper (#500~600).

NOTE:

Sand the commutator outer surface lightly and evenly.

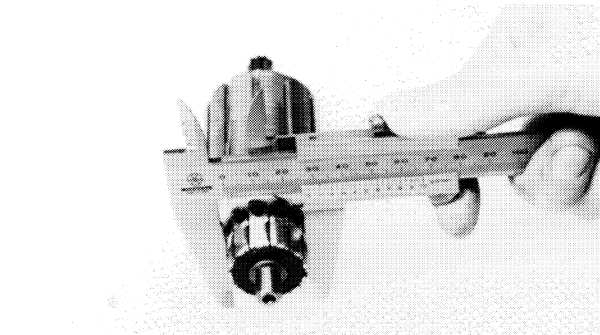

4. Measure:

- Commutator diameter
Out of specification → Replace.



Outside Diameter Limit:
27 mm (1.06 in)

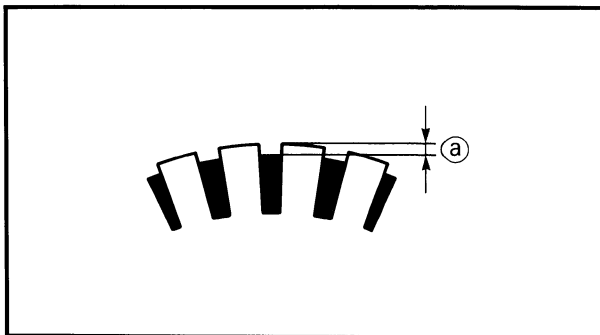

5. Measure:

- Mica undercut (a)
Out of specification → Scrape mica using a hacksaw blade.



Mica Undercut (a):
1.6 mm (0.06 in)

**NOTE:**

The mica insulation of the commutator must be undercut to ensure proper operation of the commutator.

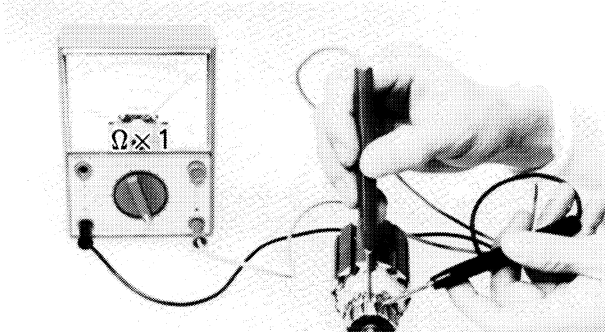

6. Measure:

- Armature coil resistance
- Out of specification → Replace.



Armature Coil Resistance:
0.012Ω at 20°C (68°F)

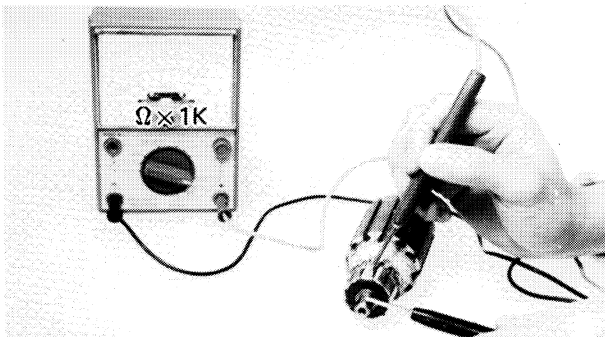

7. Check:

- Armature coil insulation
- Set the pocket tester selector to "Ω × 1K" position.
Continuity → Replace.

**Assembly**

Reverse the "Disassembly" procedure. Note the following points.

1. Install:
 - Brush assembly

NOTE:

Fit the projection onto the recess.

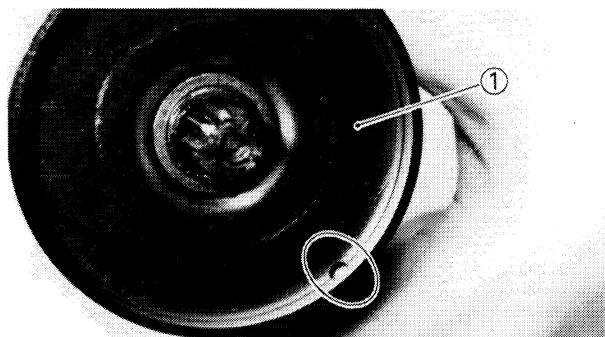

2. Install:
 - Bracket ①

NOTE:

Fit the recess to the projection.

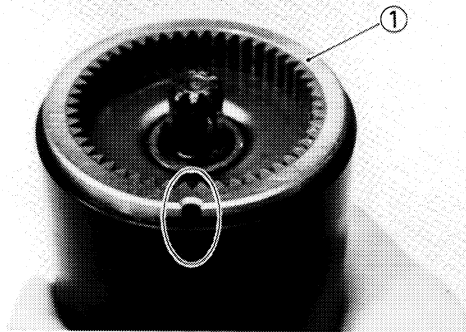

3. Install:
 • Ring gear ①

NOTE: _____
 Fit the recess to the projection.

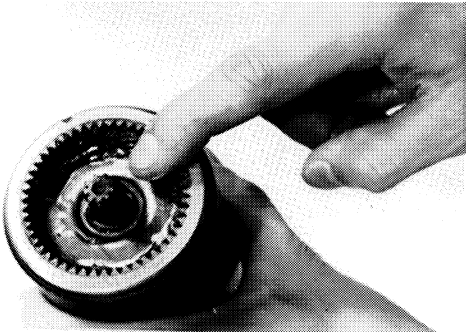

4. Apply:
 • Lithium soap base grease

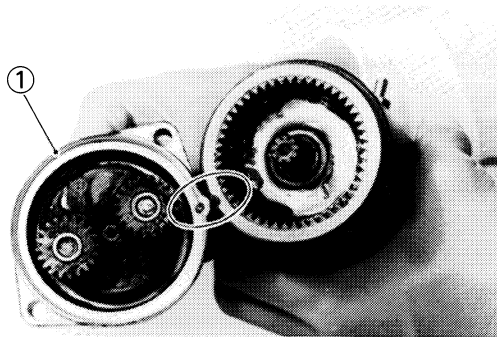

5. Install:
 • Gear assembly ①

NOTE: _____
 Fit the pin into the ring gear recess.

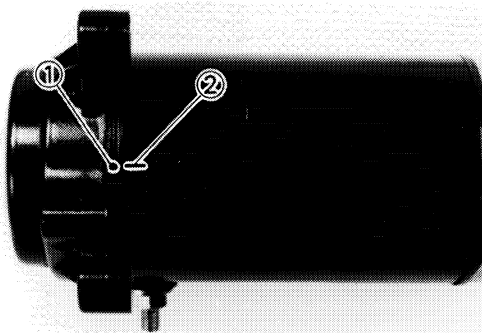

6. Install:
 • Brush cap

NOTE: _____
 Align the match mark ① on the brush cap with the match mark ② on the yoke assembly.

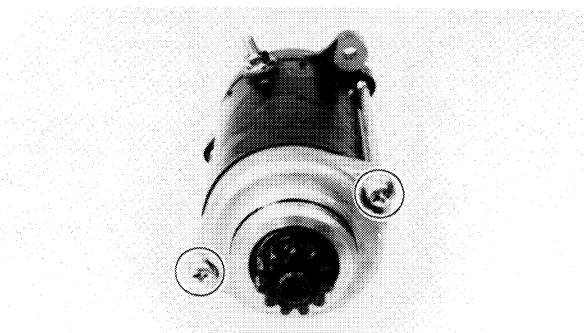

7. Install:
 • Screws

 **10 Nm (1.0 m•kg, 7.2 ft•lb)**

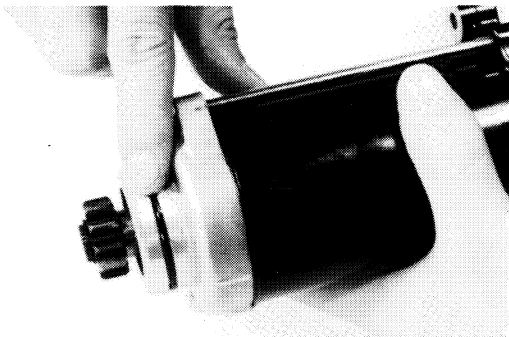
**Installation**

Reverse the "Removal" procedure. Note the following points.

1. Apply:
 - Lithium soap base grease

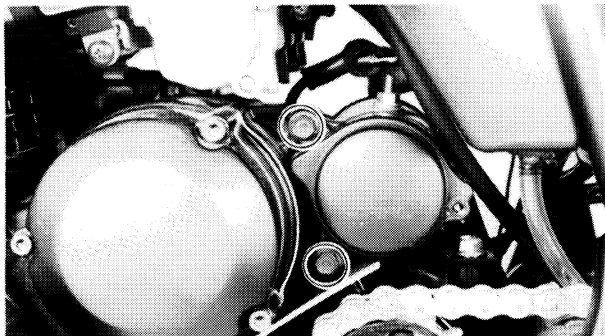

2. Install:
 - Starter motor



10 Nm (1.0 m•kg, 7.2 ft•lb)

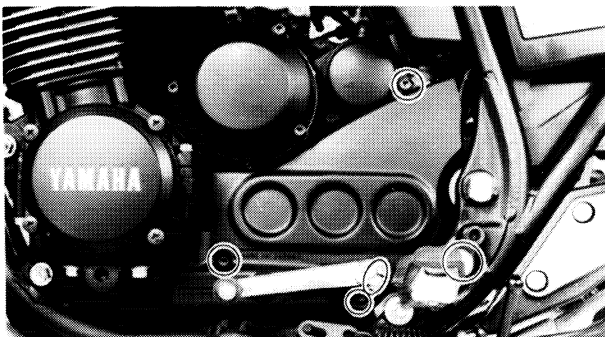

3. Install:
 - Cover (Drive sprocket)
 - Change pedal
 - Footrest (Left)



Bolt (Change pedal):
10 Nm (1.0 m•kg, 7.2 ft•lb)

Bolt (Footrest):
70 Nm (7.0 m•kg, 50 ft•lb)



MEMO

IGNITION SYSTEM

CIRCUIT DIAGRAM

Below circuit diagram shows ignition circuit.

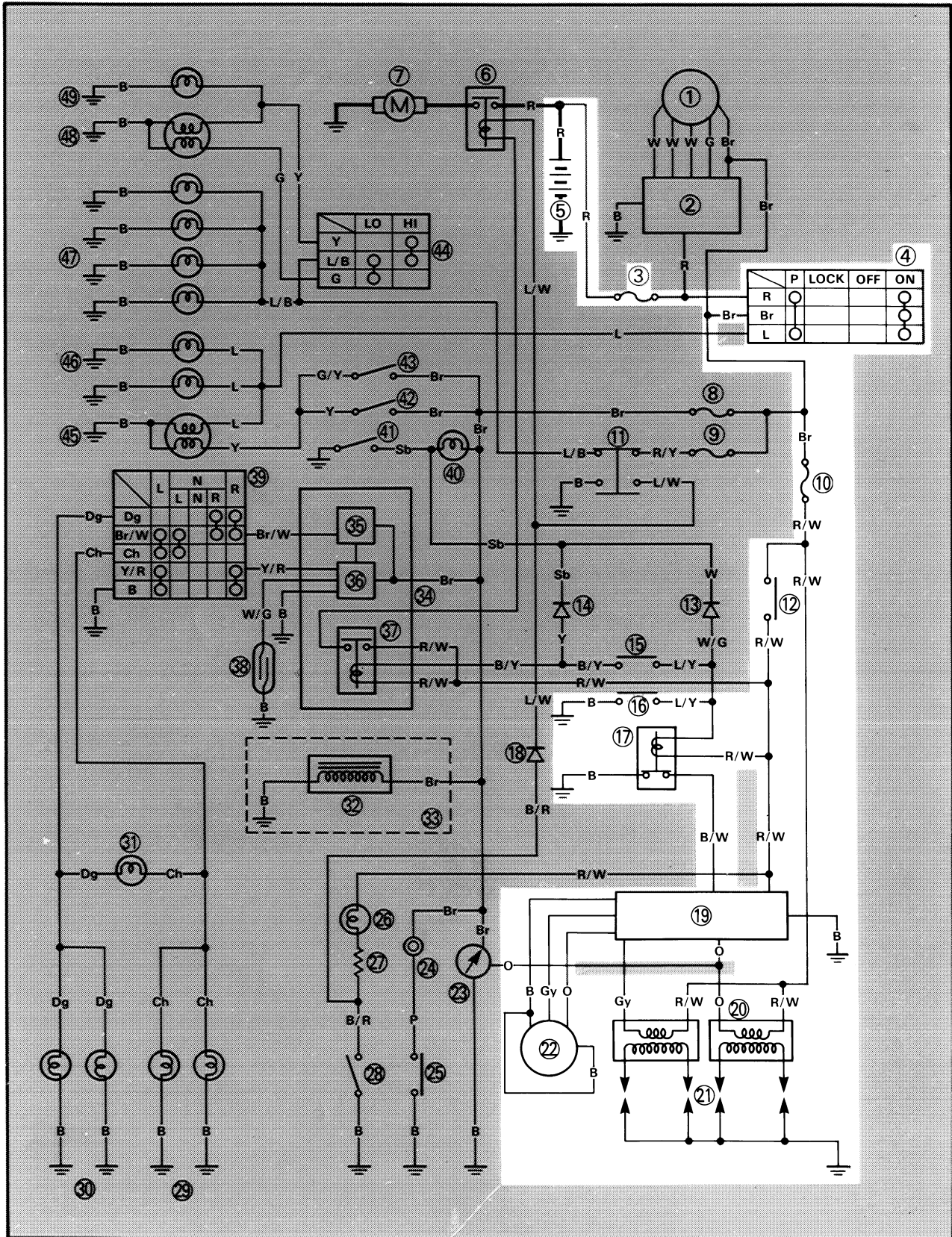

IGNITION SYSTEM

ELEC



NOTE:

For the color codes, see page 6-2.

- ③ Fuse (MAIN)
- ④ Main switch
- ⑤ Battery
- ⑩ Fuse (IGNITION)
- ⑫ "ENGINE STOP" switch
- ⑬ Sidestand switch
- ⑰ Sidestand relay
- ⑲ Ignitor unit
- ⑳ Ignition coil
- ㉑ Spark plug
- ㉒ Pickup coil

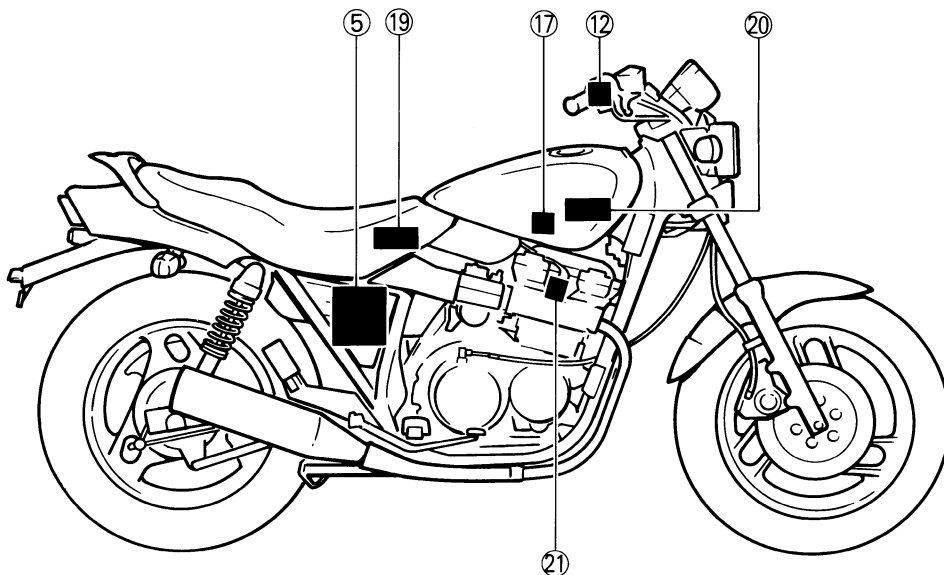
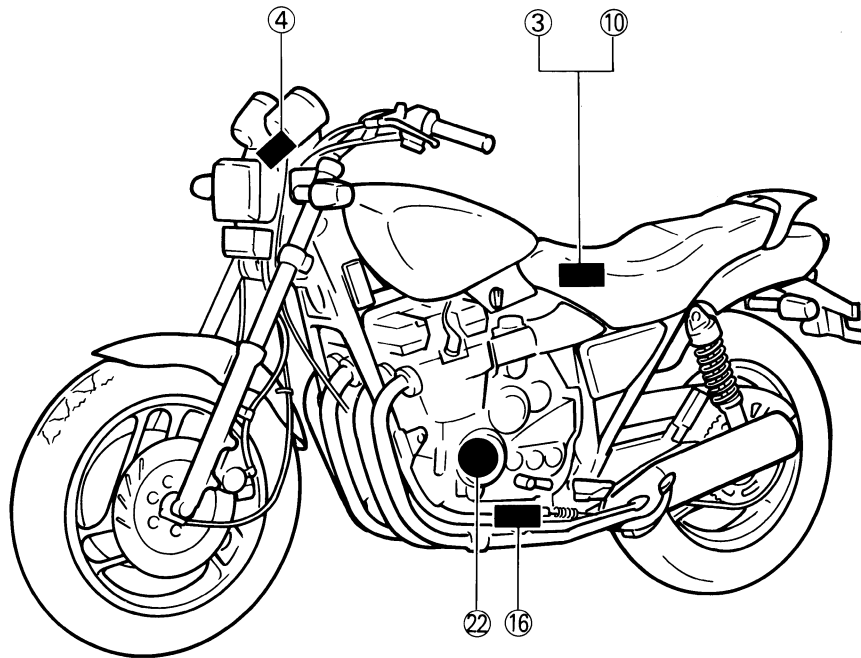



DESCRIPTION

This model is equipped with a battery operated, fully transistorized, breakerless ignition system. By using magnetic pickup coils, the need for contact breaker points is eliminated. This adds to the dependability of the system by eliminating frequent cleaning and adjustment of points and ignition timing. The TCI (Transistor Control Ignition) unit incorporates an automatic advance circuit controlled by signals generated by the pickup coil. This adds to the dependability of the system by eliminating the mechanical advancer. This TCI system consists of two units; a pickup unit and an ignitor unit.

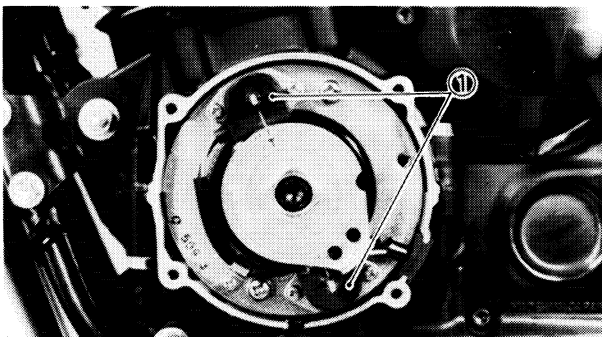
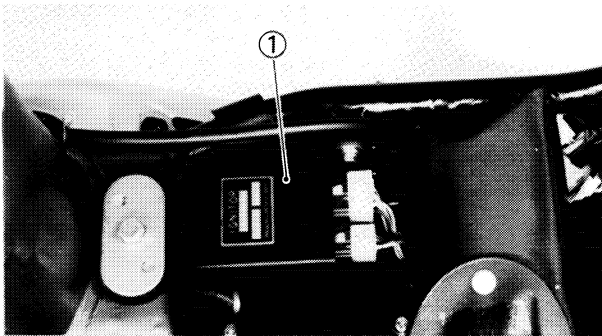

OPERATION

The TCI functions on the same principle as a conventional DC ignition system with the exception of using magnetic pickup coils and a transistor control box (TCI) in place of contact breaker points.

① TCI unit

PICKUP UNIT

The pickup unit consists of two pickup coils ① and a flywheel mounted onto the crankshaft. When the projection on the flywheel passes a pickup coil, a signal is generated and transmitted to the ignitor unit. The width of the projection on the flywheel determines the ignition advance.

The pickup coils are located in the left crankcase cover.



TROUBLESHOOTING

IF IGNITION SYSTEM SHOULD BECOME INOPERATIVE (NO SPARK OR INTERMITTENT SPARK).

Before this troubleshooting, remove following parts.

- Seat
- Fuel tank ①
- Side cover (Right) ②

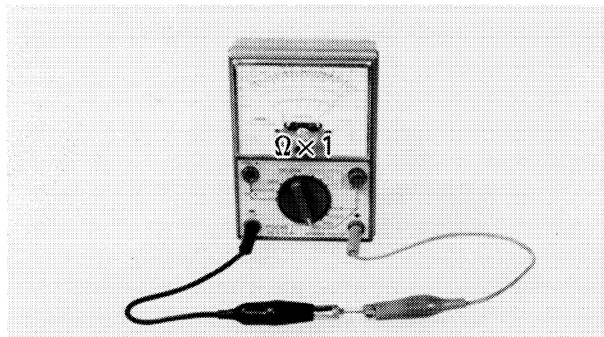
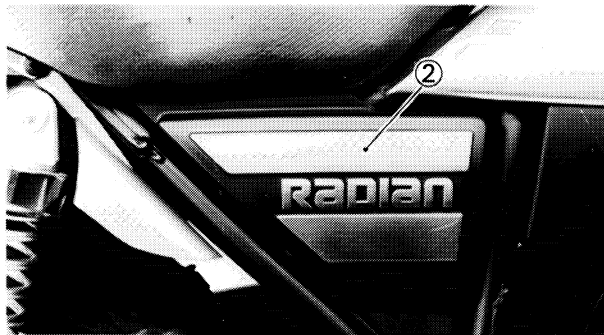
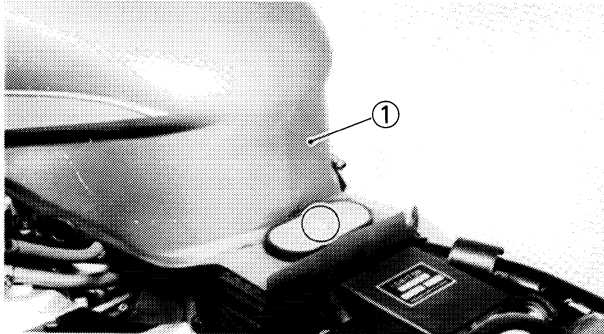

1. Fuse inspection

- Remove fuse (MAIN) and fuse (IGNITION).
- Connect Pocket Tester (YU-03112) to fuse and check it for continuity.

NOTE: _____

Set tester selector to " $\Omega \times 1$ " position.

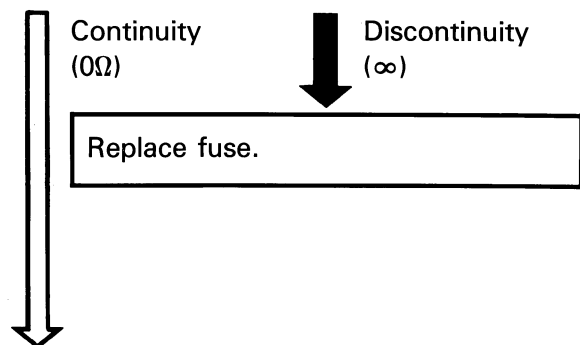



2. Battery fluid level inspection
 - Fluid level should be between upper ① and lower ② level mark.

Correct Incorrect

↓

• Refill battery fluid.

CAUTION: _____

Refill with distilled water only; tap water contains minerals harmful to a battery.



3. Battery terminal inspection
 - Inspect battery terminal and connections.

OK Dirty or poor connection

↓

• Clean battery terminals using wire brush.

NOTE: _____

After cleaning terminals, apply grease lightly to both terminals.

• Connect battery leads correctly.

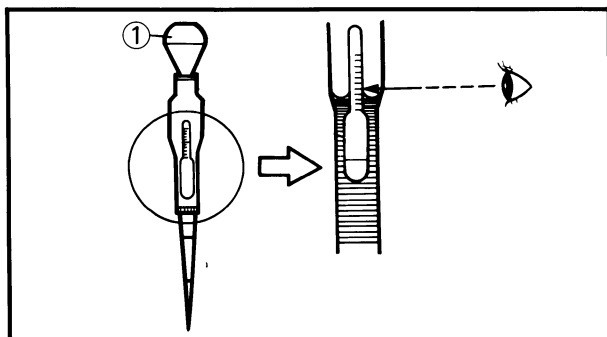

4. Battery fluid specific gravity inspection
 - Remove caps.
 - Inspect specific gravity of all cell using Battery Hydrometer ①.

Specific Gravity:
1.280 ± 0.01 at 20°C (68°F)

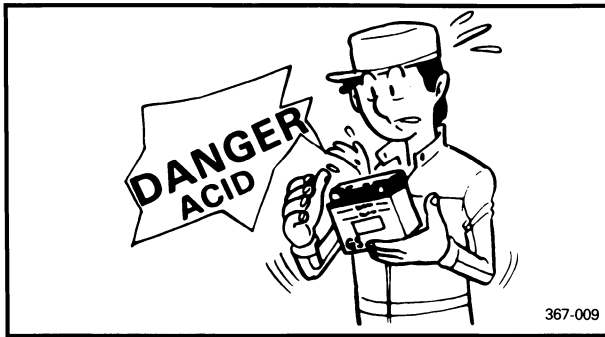

WARNING:

Battery electrolyte is poisonous and dangerous, causing severe burns, etc. It contains sulfuric acid. Avoid contact with skin, eyes or clothing. Antidote: **EXTERNAL**-Flush with water. **INTERNAL**-Drink large quantities of water or milk. Follow with milk of magnesia, beaten egg, or vegetable oil. Call a physician immediately.

Eyes: Flush with water for 15 minutes and get prompt medical attention. Batteries produce explosive gases. Keep sparks, flame, cigarettes etc., away. Ventilate when charging or using in an enclosed space. Always shield your eyes when working near batteries.

KEEP OUT OF REACH OF CHILDREN.

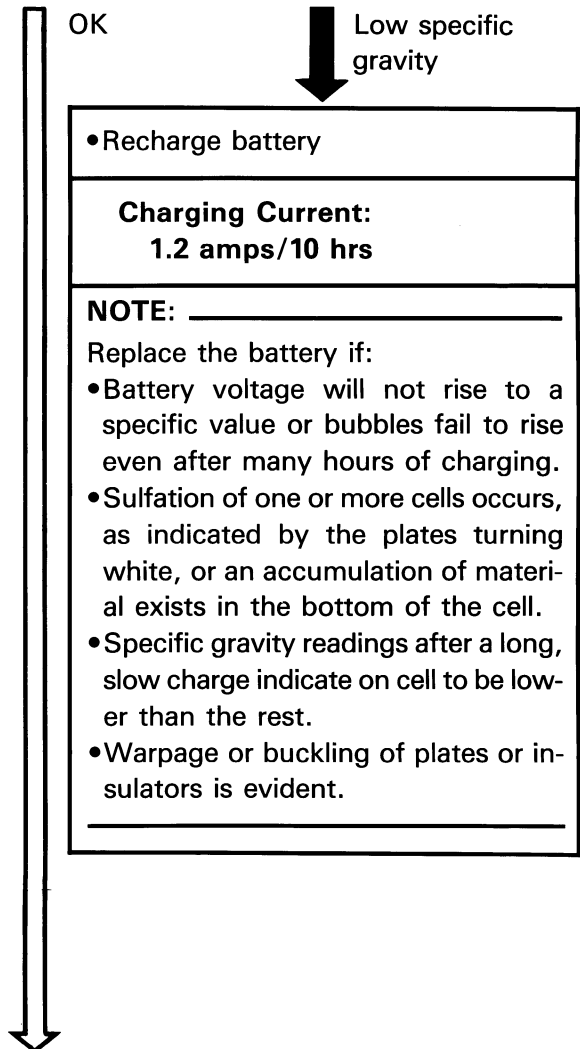



5. Spark plug inspection

- Remove spark plug.
- Clean spark plug with spark plug cleaner, if necessary.
- Inspect electrode, insulator and plug gap. Refer to "CHAPTER 2—SPARK PLUG INSPECTION" section.

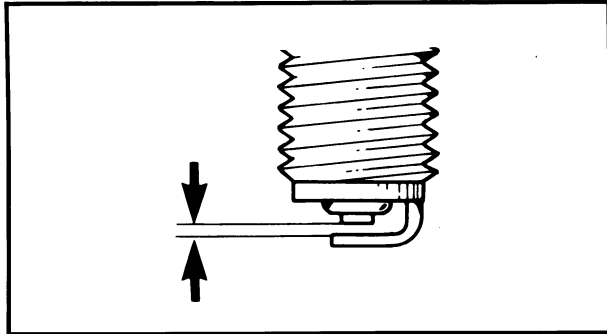

Plug Gap:

0.6 ~ 0.7 mm (0.024 ~ 0.028 in)

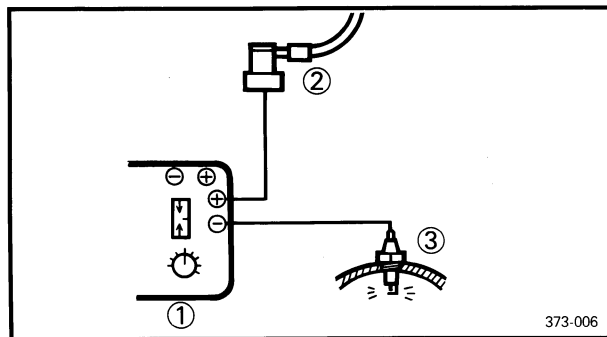

6. Ignition spark gap test

- Connect Electro Tester (YU-33260) ① as shown.

② Spark plug lead

③ Spark plug

- Start the engine, and increase the spark gap until misfire occurs. (Test at various r/min between idle and red line.)

CAUTION:

Do not run the engine in neutral above 6,000 r/min for more than 1 or 2 seconds.

Minimum Spark Gap: 6 mm (0.24 in)

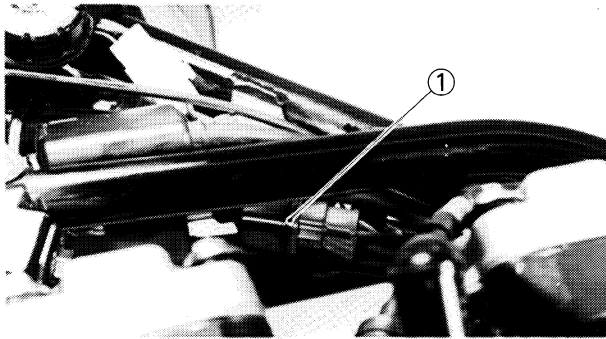

7. Sidestand relay conduct check

- Remove sidestand relay ①
- Connect 12V battery and Pocket Tester (YU-03112) to sidestand relay terminals as shown.

NOTE:

- Use full charge battery.
- Set tester selector to " $\Omega \times 1$ " position.

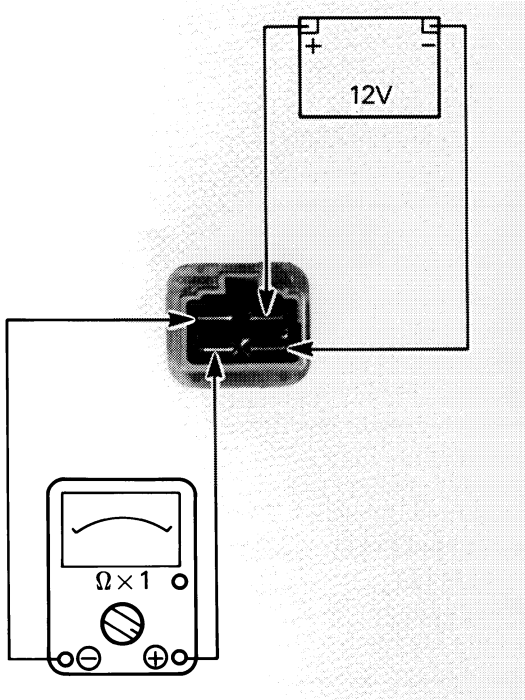

Discontinuity
(∞)

Continuity
(0Ω)

Sidestand relay is faulty, replace it.

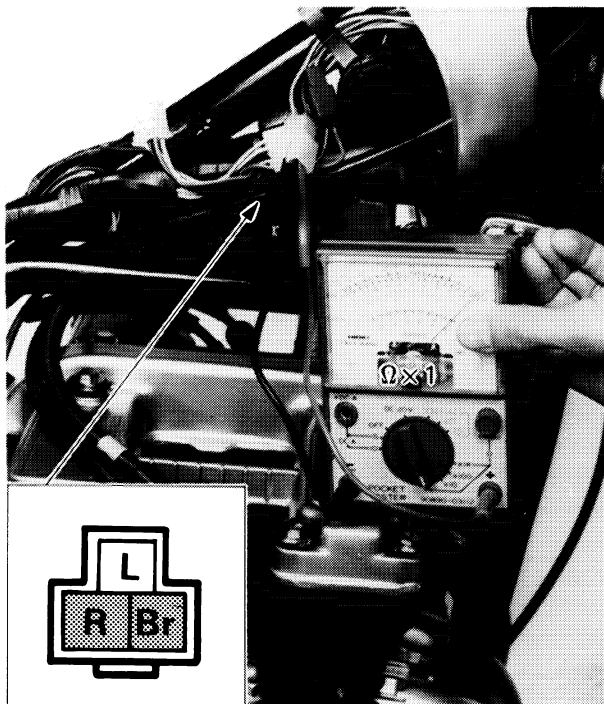

8. Main switch conduct check

- Disconnect main switch coupler (Brown, Red, Blue).
- Connect Pocket Tester (YU-03112) to main switch leads (Brown, Red).

Tester (+) lead → Red lead

Tester (-) lead → Brown lead

NOTE:

Set tester selector to " $\Omega \times 1$ " position.

- Turn main switch to "ON" position and check it for continuity.

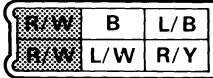
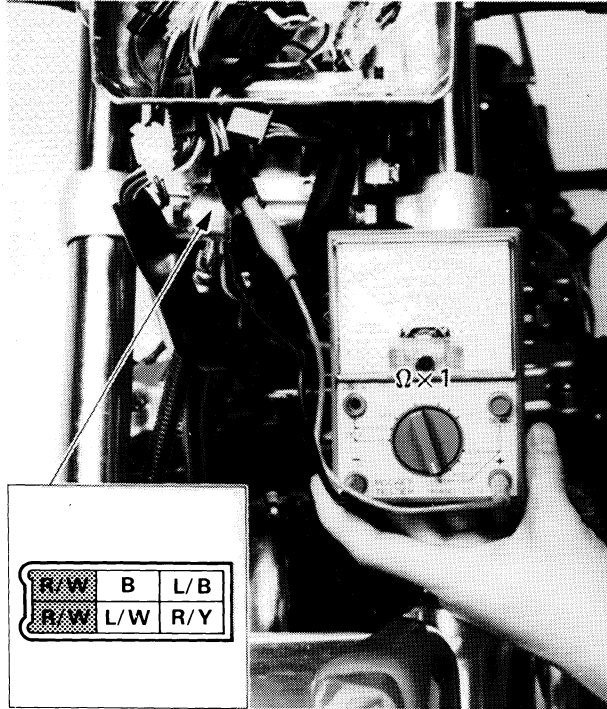

Continuity (0Ω) ↓ Discontinuity (∞)

Main switch is faulty, replace it.

9. "ENGINE STOP" switch conduct check
- Disconnect handlebar switch (Right) leads (Red/White, Red/White, Red/Yellow, Blue/Black, Blue/White, Black).
 - Connect Pocket Tester (YU-03112) to handlebar switch lead (Red/White, Red/White).

Tester (+) lead → Red/White lead
 Tester (-) lead → Red/White lead

NOTE: _____
 Set tester selector to "Ω × 1" position.

- Turn "ENGINE STOP" switch to "RUN" position.

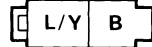
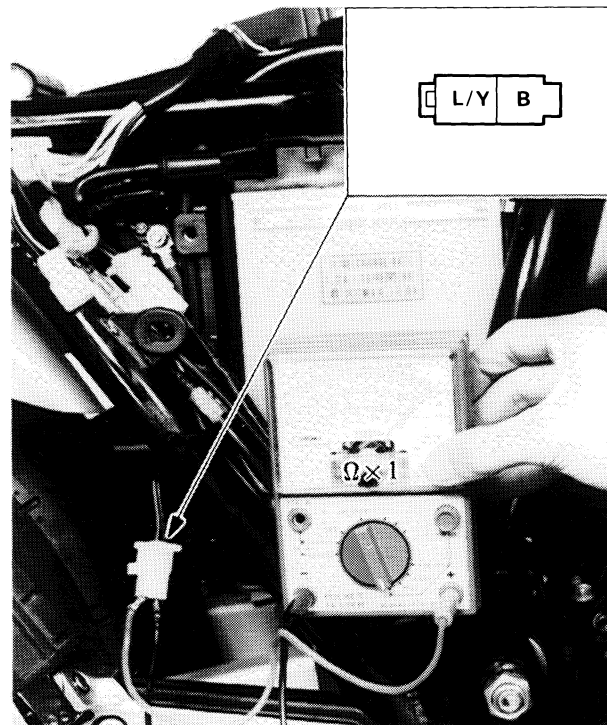

Continuity (0Ω) ↓ Discontinuity (∞)

"ENGINE STOP" switch is faulty, replace handlebar switch.

10. Sidestand switch conduct check
- Disconnect sidestand leads (Blue/Yellow, Black).
 - Connect Pocket Tester (YU-03112) to sidestand switch leads.

Tester (+) lead → Blue/Yellow lead
 Tester (-) lead → Black lead



NOTE:

Set tester selector to " $\Omega \times 1$ " position.

- Place motorcycle on centerstand.
- Sidestand is up and check sidestand switch for continuity.

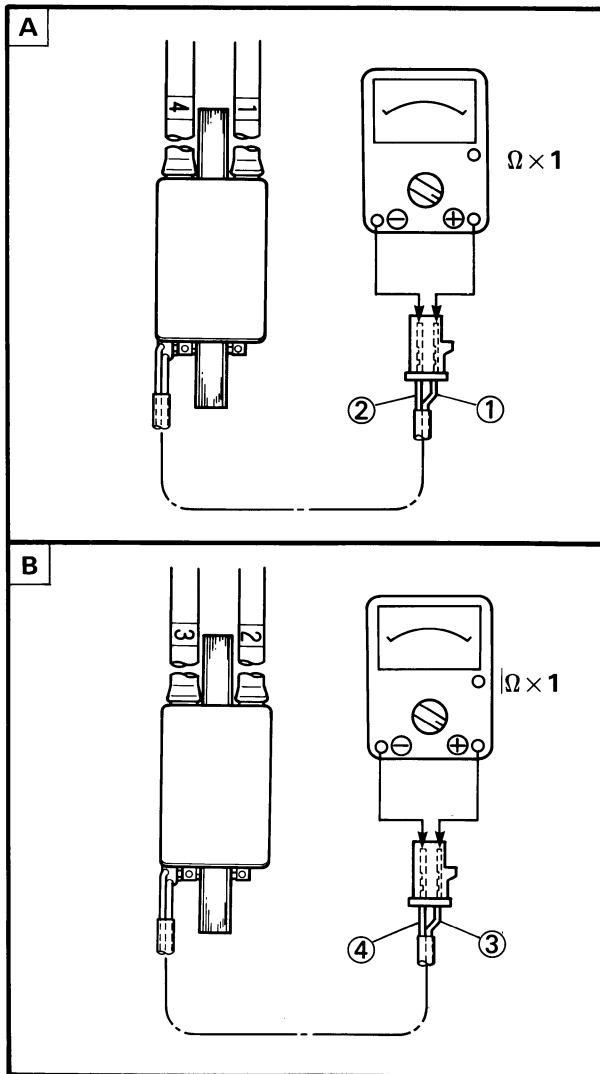
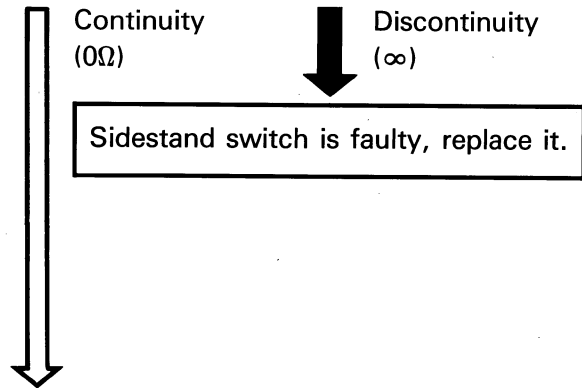

11. Ignition coil resistance test

- Disconnect ignition coil leads and spark plug leads.
- Connect Pocket Tester (YU-03112) to ignition coil lead.

A Ignition coil for #1, #4 cylinder

Tester (+) lead → Orange lead ①

Tester (-) lead → Red/White lead ②

B Ignition coil for #2, #3 cylinder

Tester (+) lead → Gray lead ③

Tester (-) lead → Red/White lead ④

- Measure primary coil resistance



Primary Coil Resistance:

2.43 ~ 2.97 Ω at 20°C (68°F)

NOTE:

Set tester selector to " $\Omega \times 1$ " position.

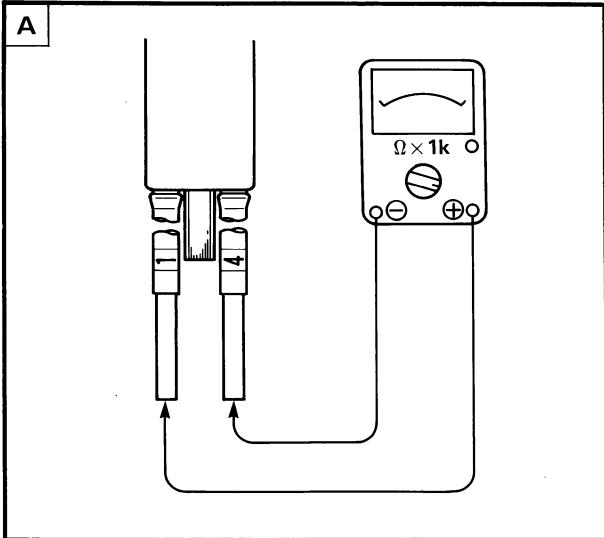

- Connect Pocket Tester (YU-03112) to spark plug leads.

A Ignition coil for # 1, # 4 cylinder
 Tester (+) lead → # 1 spark plug lead
 Tester (-) lead → # 4 spark plug lead

B Ignition coil for # 2, # 3 cylinder
 Tester (+) lead → # 2 spark plug lead
 Tester (-) lead → # 3 spark plug lead

- Measure secondary coil resistance.



Secondary Coil Resistance:
 10.56 ~ 15.84 kΩ at 20°C (68°F)

NOTE: _____
 Set tester selector to "Ω × 1K" position.

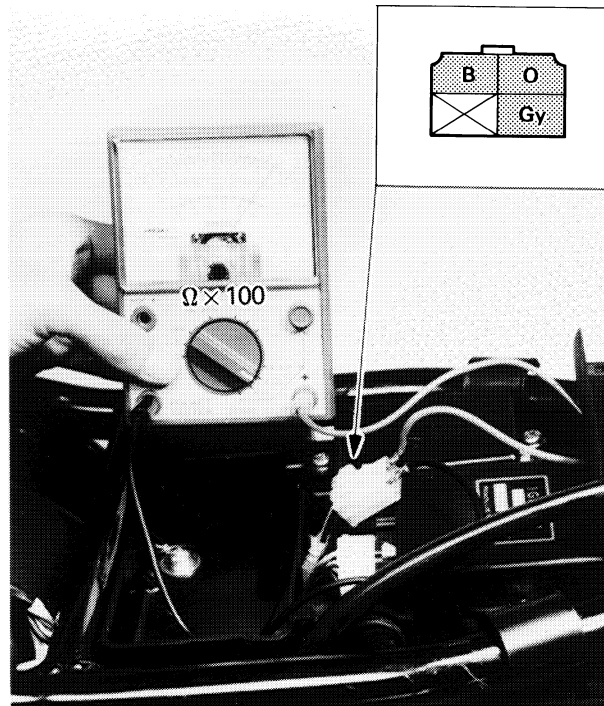
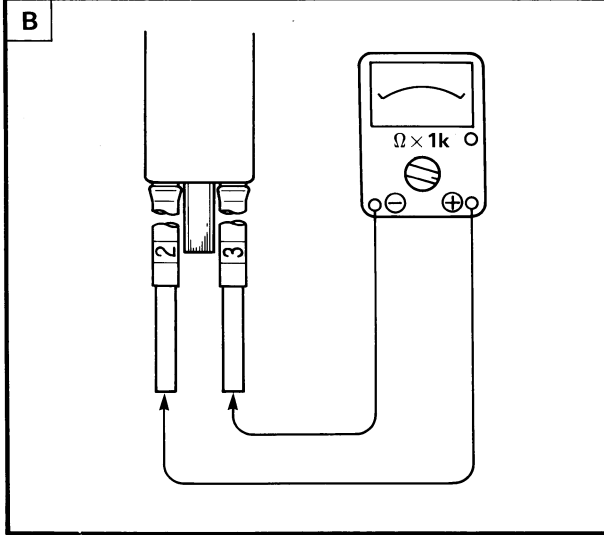
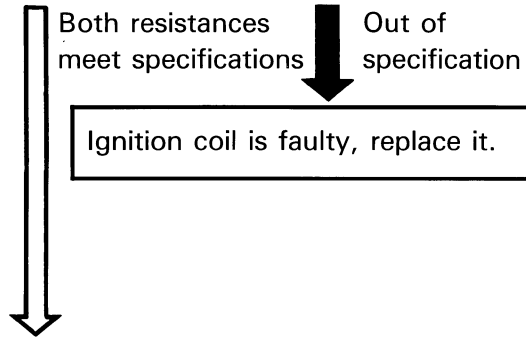

12. Pickup coil resistance test.

- Disconnect pickup coil leads (Orange, Gray, Black) at ignitor unit.
- Connect Pocket Tester (YU-03112) to pickup coil leads.

Tester (+) lead → Orange lead
 Tester (-) lead → Black lead

Tester (+) lead → Gray lead
 Tester (-) lead → Black lead

- Measure pickup coil resistance.



Pickup Coil Resistance:
 108 ~ 132 Ω at 20°C (68°F)

NOTE: _____
 Set tester selector to "Ω × 100" position.



Both resistances
meet specifications

Out of
specification

Pickup coil is faulty, replace it.

13. Check entire ignition system for connections.
Refer to "WIRING DIAGRAM" section.

OK

Poor
connection

Correct.

Ignitor unit is faulty, replace it.

CHARGING SYSTEM

CIRCUIT DIAGRAM

Below circuit diagram shows charging circuit.

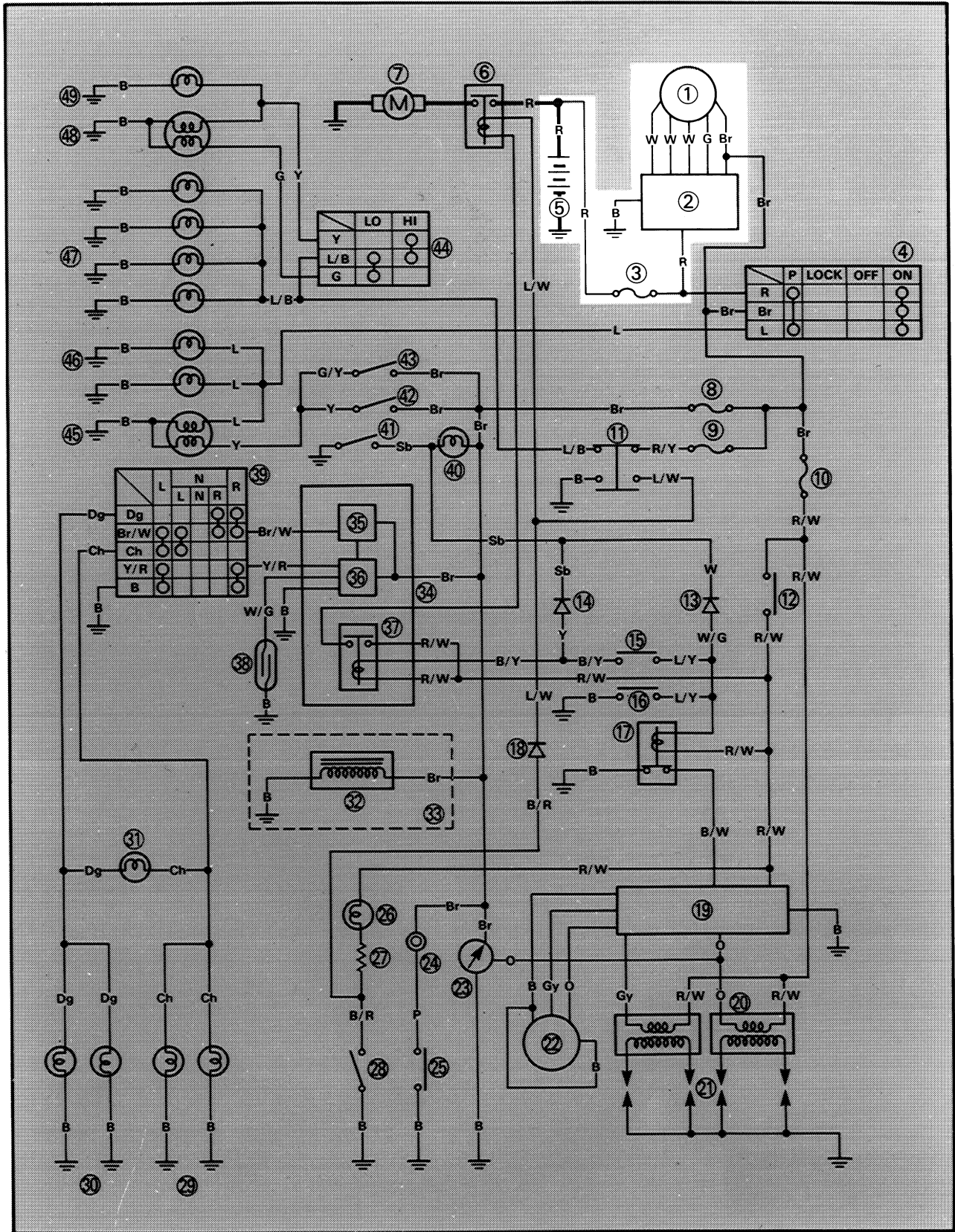



NOTE: _____

For the color codes, see page 6-2.

- ① AC Magneto
- ② Rectifier/Regulator
- ③ Fuse (MAIN)
- ⑤ Battery

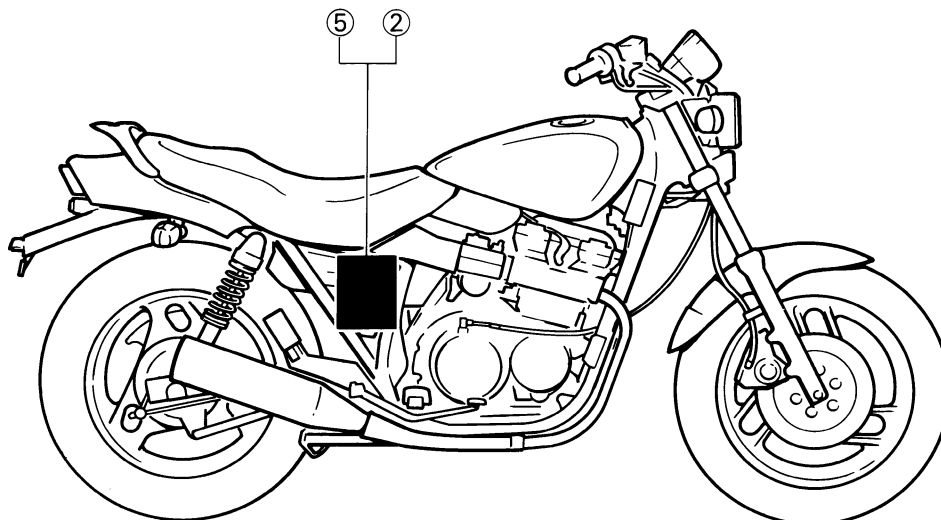
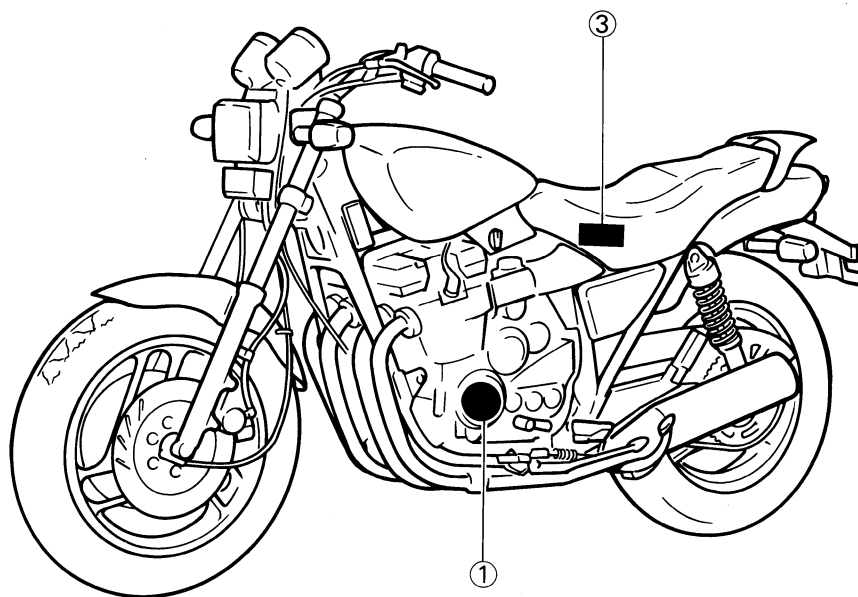

TROUBLESHOOTING

THE BATTERY IS NOT CHARGED.

Before this troubleshooting, remove following parts.

- Seat
- Side cover (Right)

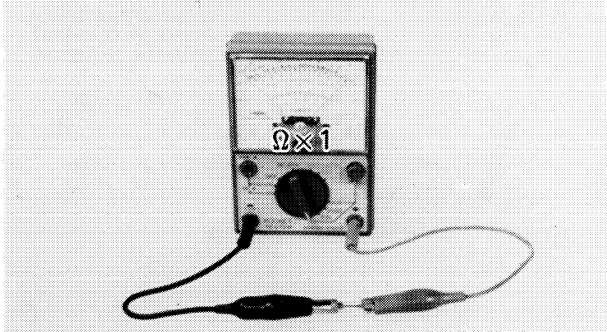

1. Fuse inspection
 - Remove fuse (MAIN).
 - Connect Pocket Tester (YU-03112) to fuse and check it for continuity.

NOTE: _____
 Set tester selector to “Ω × 1” position.

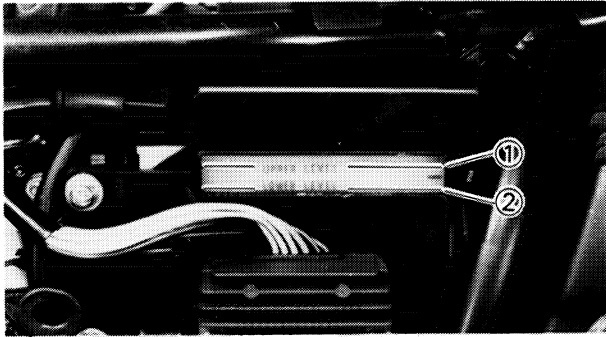
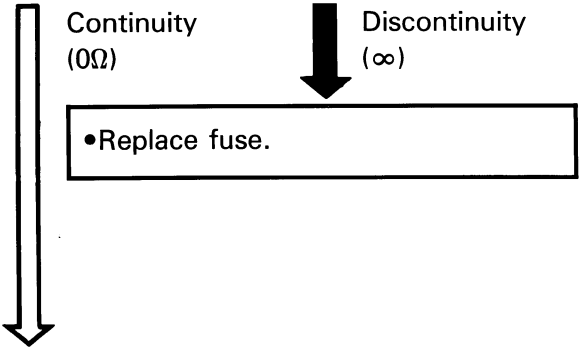

2. Battery fluid level inspection
 - Fluid level should be between upper ① and lower ② level mark.

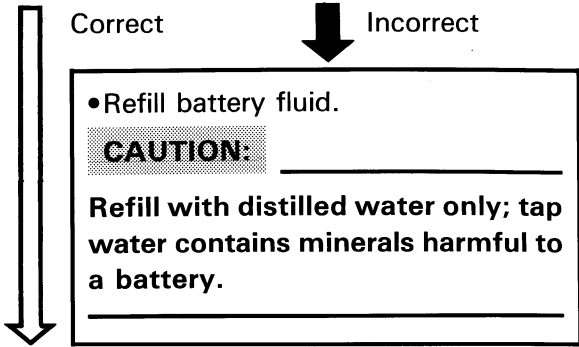



3. Battery terminal inspection

- Inspect battery terminal and connections.

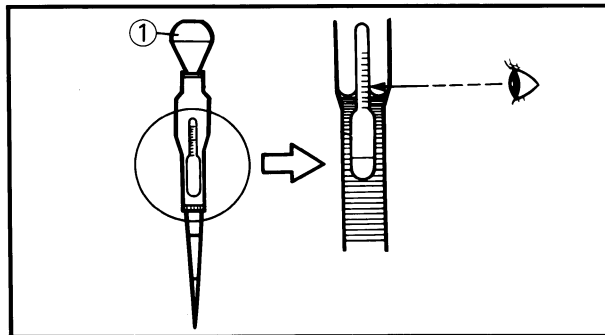
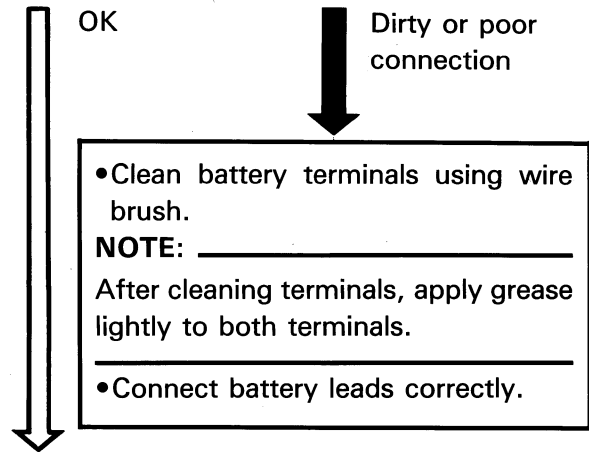

4. Battery fluid specific gravity inspection

- Remove caps.
- Inspect specific gravity of all cell using Battery Hydrometer ①.

Specific Gravity:
 1.280 ± 0.01 at 20°C (68°F)



WARNING: _____

Battery electrolyte is poisonous and dangerous, causing severe burns, etc. It contains sulfuric acid. Avoid contact with skin, eyes or clothing. Antidote: EXTERNAL-Flush with water. INTERNAL-Drink large quantities of water or milk. Follow with milk of magnesia, beaten egg, or vegetable oil. Call a physician immediately.

Eyes: Flush with water for 15 minutes and get prompt medical attention. Batteries produce explosive gases. Keep sparks, flame, cigarettes etc., away. Ventilate when charging or using in an enclosed space. Always shield your eyes when working near batteries.

KEEP OUT OF REACH OF CHILDREN.



OK

Low specific gravity
↓

- Recharge battery.

Charging Current:
1.2 amps/10 hrs

NOTE:

Replace the battery if:

- Battery voltage will not rise to a specific value or bubbles fail to rise even after many hours of charging.
- Sulfation of one or more cells occurs, as indicated by the plates turning white, or an accumulation of material exists in the bottom of the cell.
- Specific gravity readings after a long, slow charge indicate on cell to be lower than the rest.
- Warp or buckling of plates or insulators is evident.



5. Charging voltage test

- Connect Pocket Tester (YU-03112) to battery.

NOTE:

Set tester selector to "DC20V" position.

Tester (+) lead → Battery (+) terminal
Tester (-) lead → Battery (-) terminal

- Start engine and accelerate to about 5,000 r/min.
- Measure charging voltage.



Charging Voltage:
14 ~ 15 V at 5,000 r/min



Out of specification

Charging voltage meets specification

Battery is faulty, replace it.

6. Stator coil resistance test

- Disconnect AC magneto leads (White, White, White).
- Connect Pocket Tester (YU-03112) to AC magneto leads.

NOTE:

Set tester selector to " $\Omega \times 1$ " position.

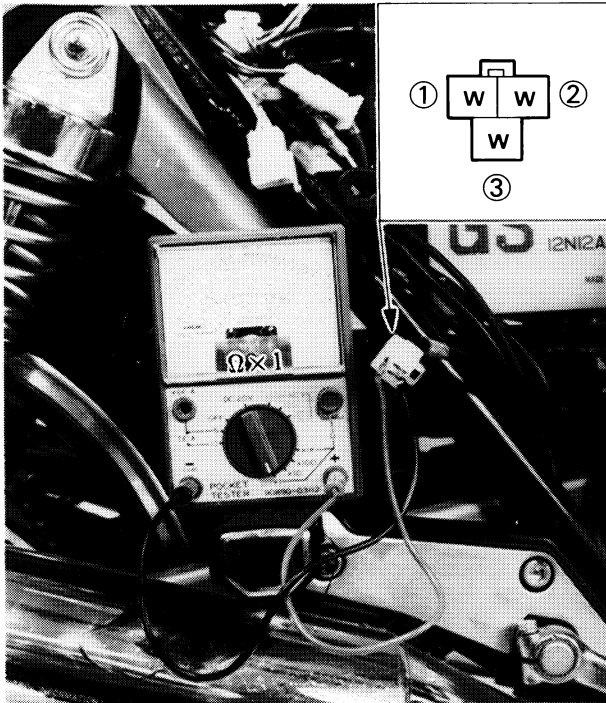

Stator Coil (1)

- Tester (+) lead → White lead ①
- Tester (-) lead → White lead ③

Stator Coil (2)

- Tester (+) lead → White lead ②
- Tester (-) lead → White lead ③

- Measure stator coil resistance.



Stator Coil Resistance:

- White ① - White ②
0.5 ~ 0.6 Ω at 20°C (68°F)
- White ② - White ③
0.5 ~ 0.6 Ω at 20°C (68°F)

Both resistances meet specifications

Out of specification

Stator coil is faulty, replace it.

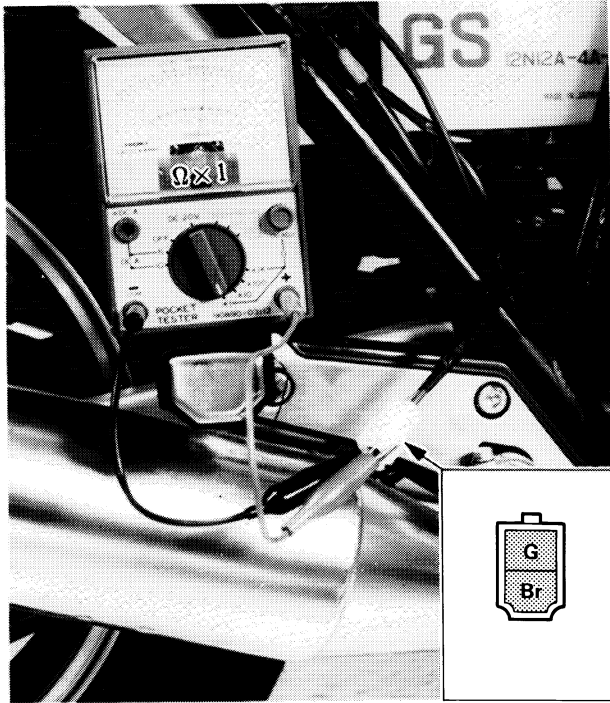

7. Field coil resistance test.

- Disconnect AC magneto leads (Green, Brown).
- Connect Pocket Tester (YU-03112) to AC magneto leads.

NOTE: _____

Set tester selector "Ω × 1" position.

Tester (+) lead → Green lead
 Tester (-) lead → Brown lead

- Measure field coil resistance.

 **Field Coil Resistance:**
 2.7 ~ 3.3Ω at 20°C (68°F)

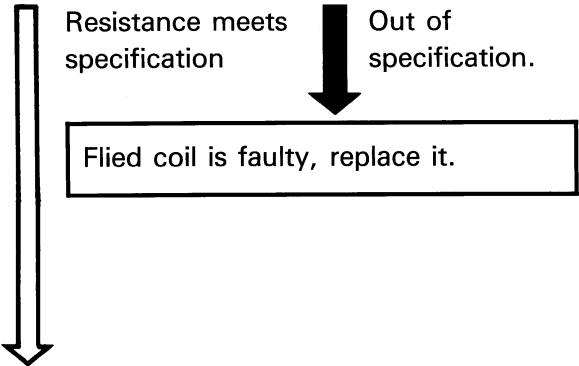

8. Check entire charging system for connections. Refer to "WIRING DIAGRAM" section.

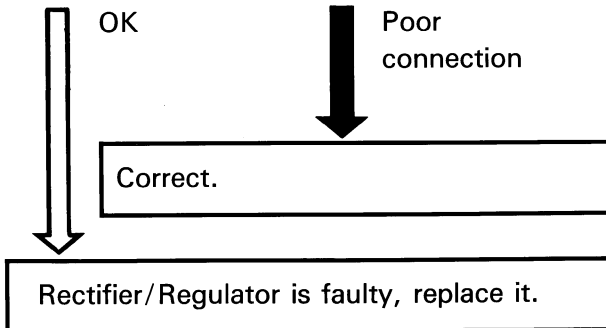



MEMO

LIGHTING SYSTEM

CIRCUIT DIAGRAM

Below circuit diagram shows lighting circuit.

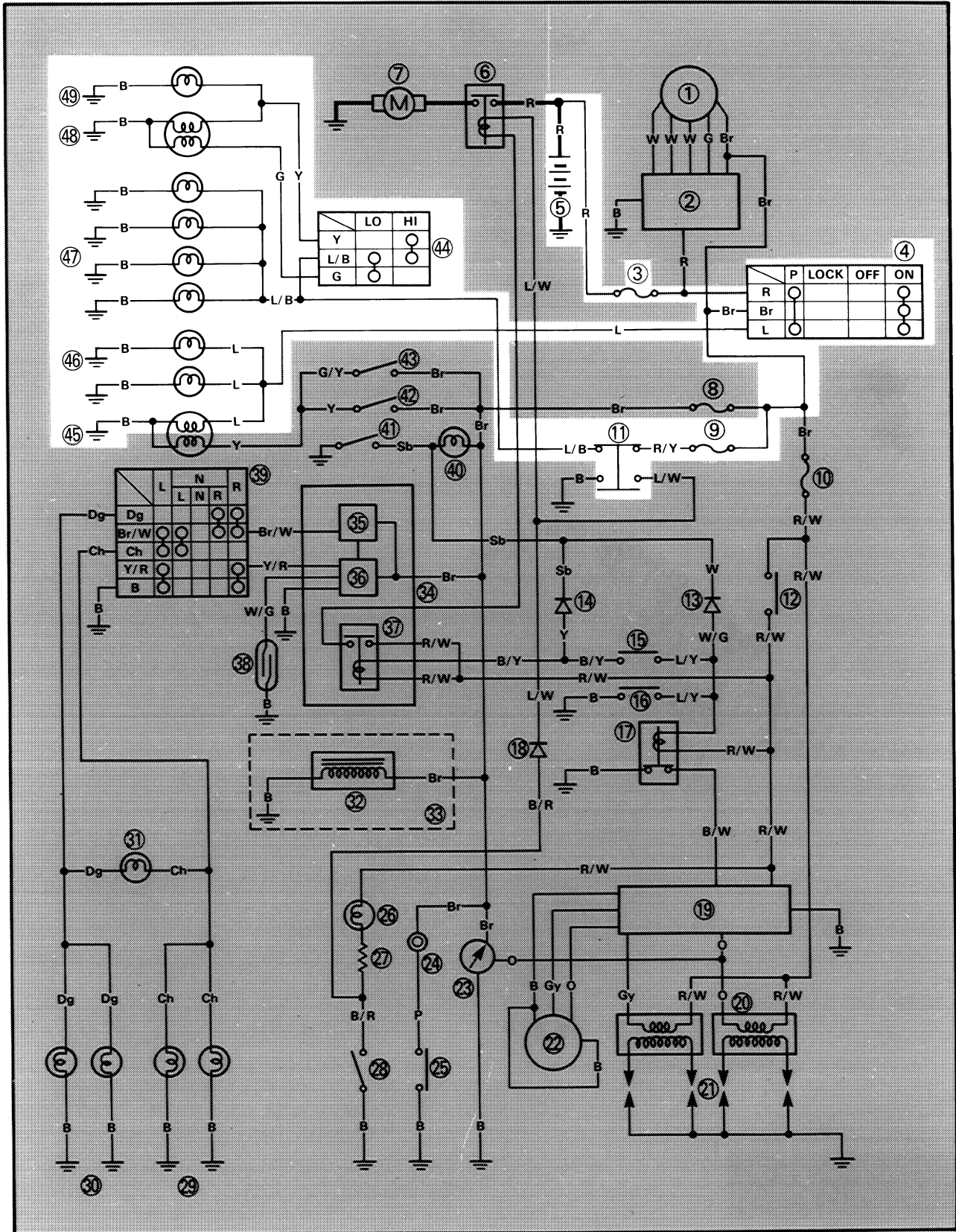



NOTE: _____

For the color codes, see page 6-2.

- ③ Fuse (MAIN)
- ④ Main switch
- ⑤ Battery
- ⑨ Fuse (HEAD)
- ⑪ "START" switch
- ④④ "LIGHTS" (Dimmer) switch
- ④⑤ Tail/Brake light
- ④⑥ License light
- ④⑦ Meter light
- ④⑧ Headlight
- ④⑨ "HIGH BEAM" indicator light

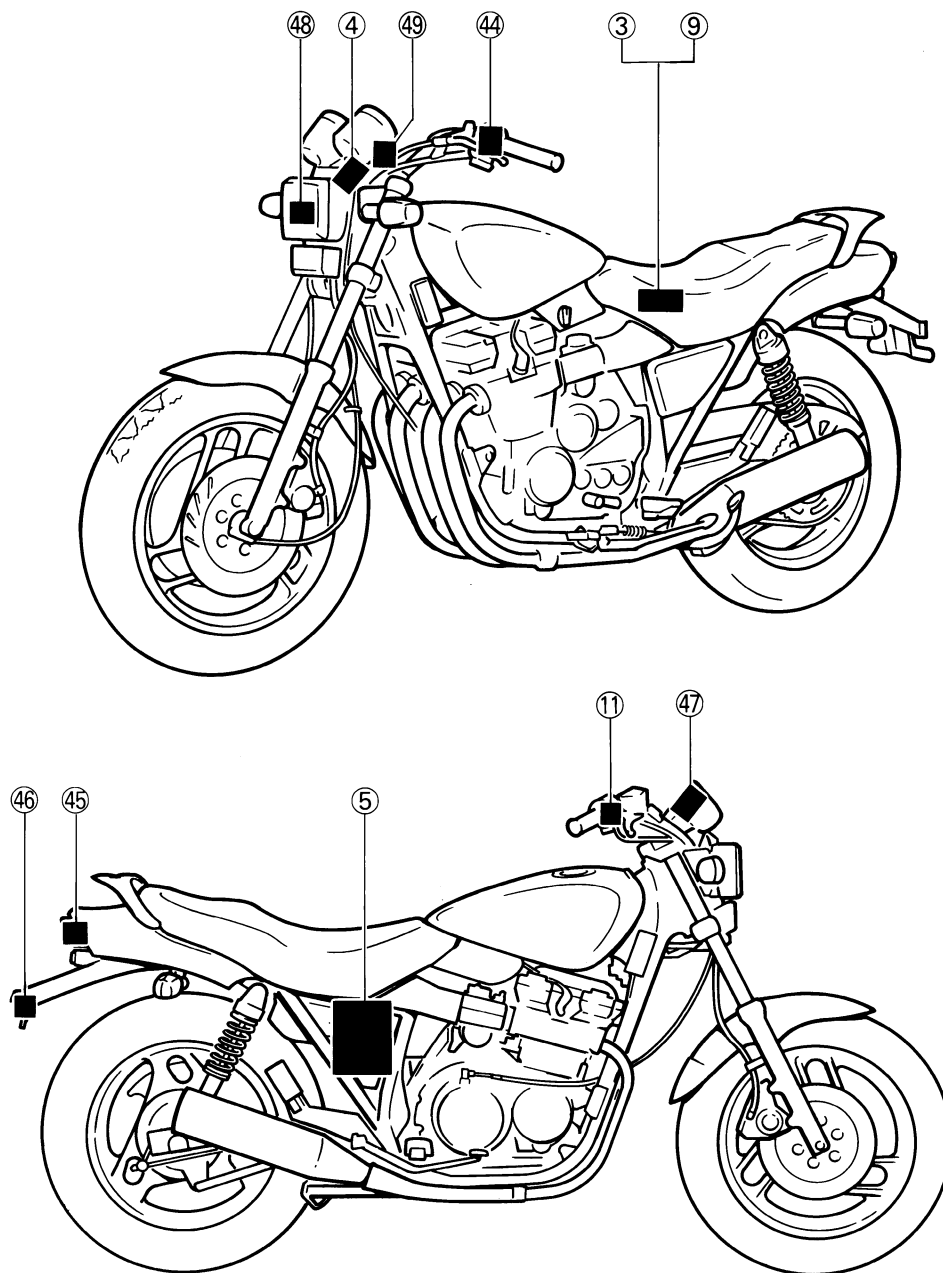

**TROUBLESHOOTING**

The battery provides power for operation of the headlight, taillight, license light and meter light. If none of the above fail to operate proceed further. Low battery voltage indicates either a faulty battery, low battery fluid level or a defective charging system.

Also check fuse condition. Replace any "Open" fuses.

HEADLIGHT, TAILLIGHT, LICENSE LIGHT AND METER LIGHT DO NOT COME ON.

Before this troubleshooting, remove following parts.

- Seat
- Fuel tank ①
- Side cover (Right) ②

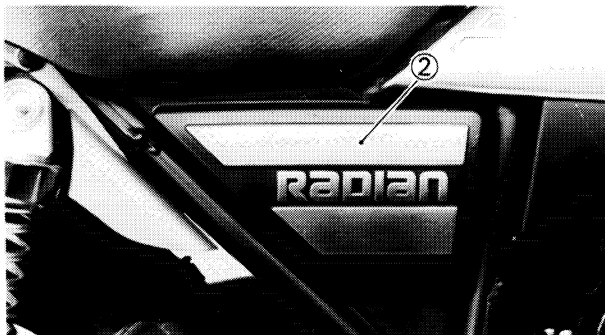
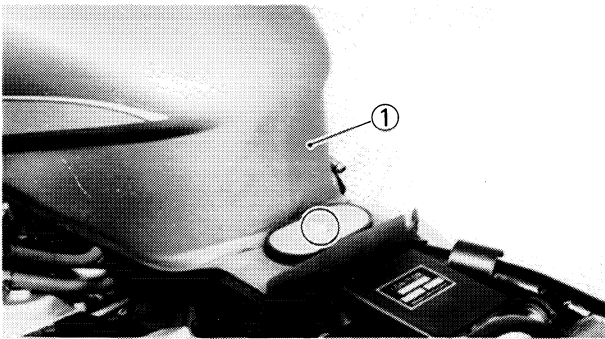



NOTE:

Check each bulb first before performing the following check.

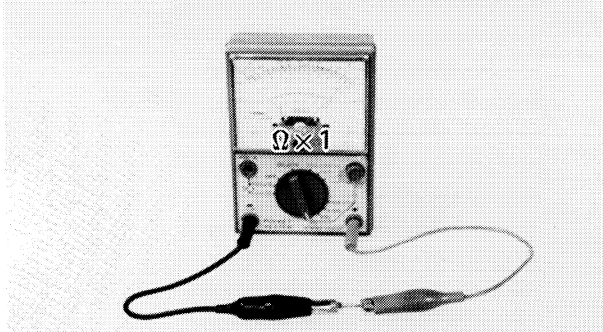

1. Fuse inspection

- Remove fuse (MAIN) and fuse (HEAD).
- Connect Pocket Tester (YU-03112) to fuse and check it for continuity.

NOTE:

Set tester selector to “Ω × 1” position.

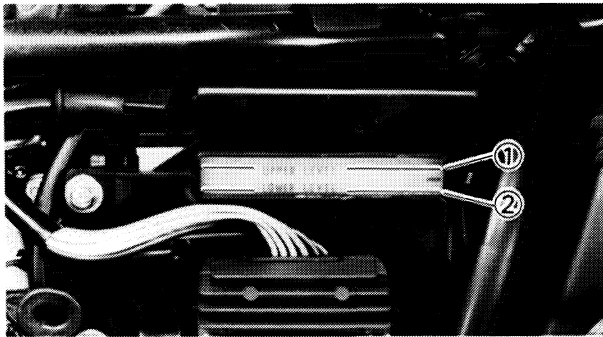
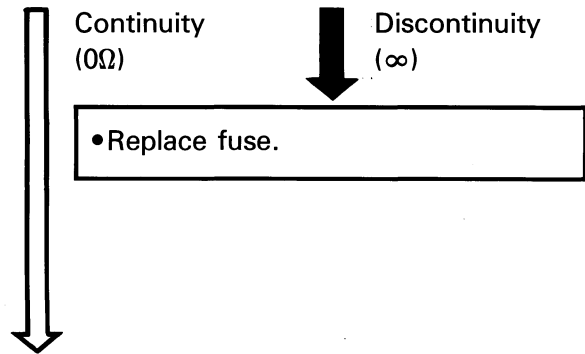

2. Battery fluid level inspection

- Fluid level should be between upper ① and lower ② level mark.

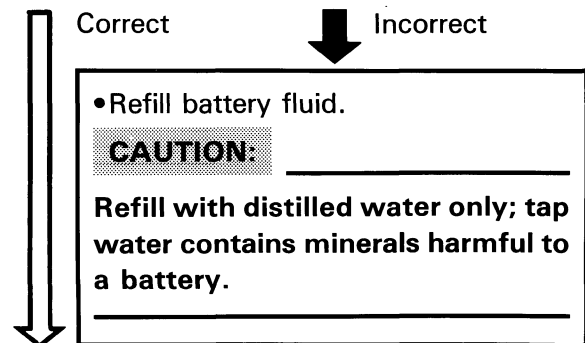



3. Battery terminal inspection

- Inspect battery terminal and connections.

OK

Dirty or poor connection

- Clean battery terminals using wire brush.

NOTE: _____

After cleaning terminals, apply grease lightly to both terminals.

- Connect battery leads correctly.

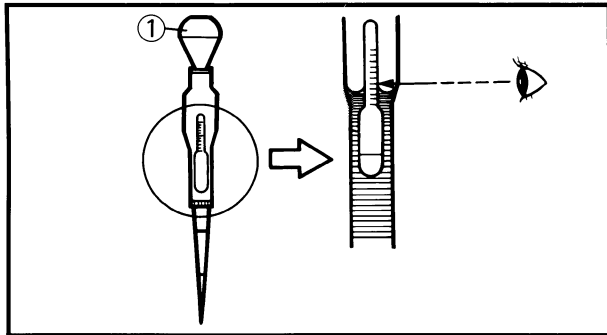

4. Battery fluid specific gravity inspection

- Remove caps.
- Inspect specific gravity of all cell using Battery Hydrometer ①.

Specific Gravity:
 1.280 ± 0.01 at 20°C (68°F)

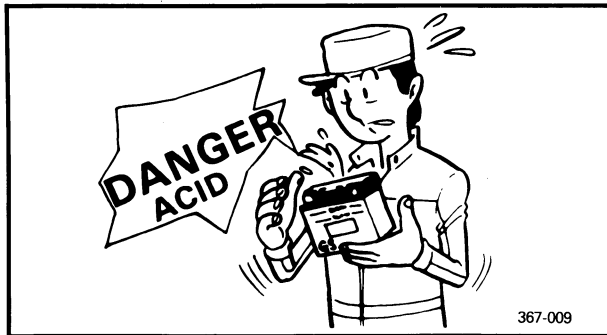

WARNING: _____

Battery electrolyte is poisonous and dangerous, causing severe burns, etc. It contains sulfuric acid. Avoid contact with skin, eyes or clothing. Antidote: EXTERNAL-Flush with water. INTERNAL-Drink large quantities of water or milk. Follow with milk of magnesia, beaten egg, or vegetable oil. Call a physician immediately.

Eyes: Flush with water for 15 minutes and get prompt medical attention. Batteries produce explosive gases. Keep sparks, flame, cigarettes etc., away. Ventilate when charging or using in an enclosed space. Always shield your eyes when working near batteries.

KEEP OUT OF REACH OF CHILDREN.



OK

Low specific gravity

- Recharge battery.

Charging Current:
1.2 amps/10 hrs

NOTE: _____

Replace the battery if:

- Battery voltage will not rise to a specific value or bubbles fail to rise even after many hours of charging.
- Sulfation of one or more cells occurs, as indicated by the plates turning white, or an accumulation of material exists in the bottom of the cell.
- Specific gravity readings after a long, slow charge indicate on cell to be lower than the rest.
- Warpage or buckling of plates or insulators is evident.

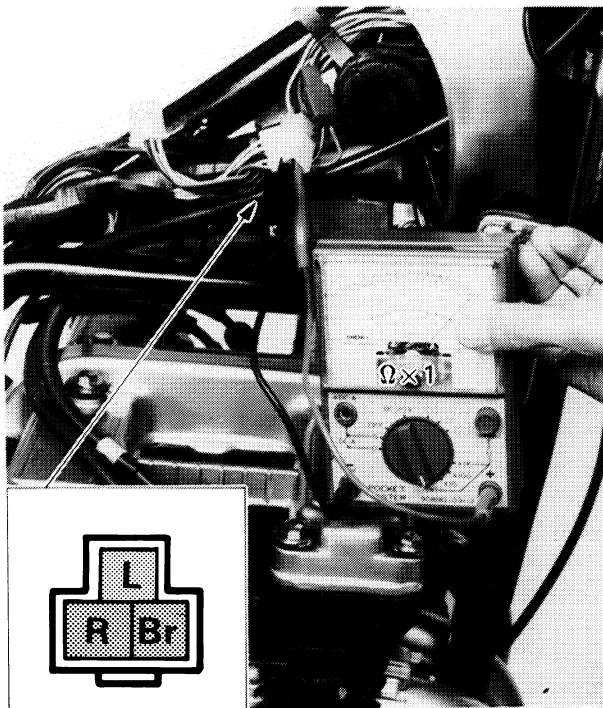

5. Main switch conduct check

- Disconnect main switch coupler (Brown, Red, Blue).
- Connect Pocket Tester (YU-03112) to main switch leads.

Tester (+) lead → Red lead

Tester (-) lead → Brown lead

Tester (+) lead → Red lead

Tester (-) lead → Blue lead

NOTE: _____

Set tester selector to "Ω × 1" position.

- Turn main switch to "ON" position and check it for continuity.



Continuity exists on both circuits Continuity does not exist on one circuit

Main switch is faulty, replace it.

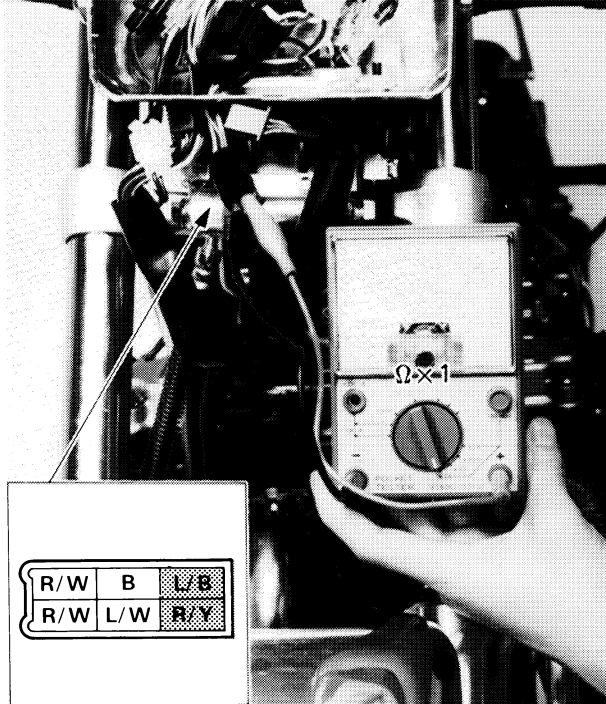

6. "START" switch conduct check

- Disconnect handlebar switch (Right) leads (Red/White, Red/White, Red/Yellow, Blue/Black, Blue/White, Black).
- Connect Pocket Tester (YU-03112) to handlebar switch leads (Blue/Black, Red/Yellow).

Tester (+) lead → Blue/Black lead
 Tester (-) lead → Red/Yellow lead

NOTE:

Set tester selector to " $\Omega \times 1$ " position.

Continuity (0Ω)

Discontinuity (∞)

"START" switch is faulty, replace handlebar switch.

7. Check entire lighting system for connections. Refer to "WIRING DIAGRAM" section.

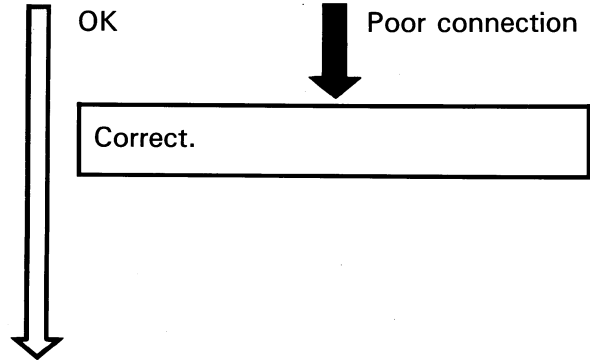

8. Check condition of each circuit for lighting system.
Refer to "LIGHTING SYSTEM TEST AND CHECKS" section.

LIGHTING SYSTEM TEST AND CHECKS

Headlight and/or "HIGH BEAM" indicator light do not come on.

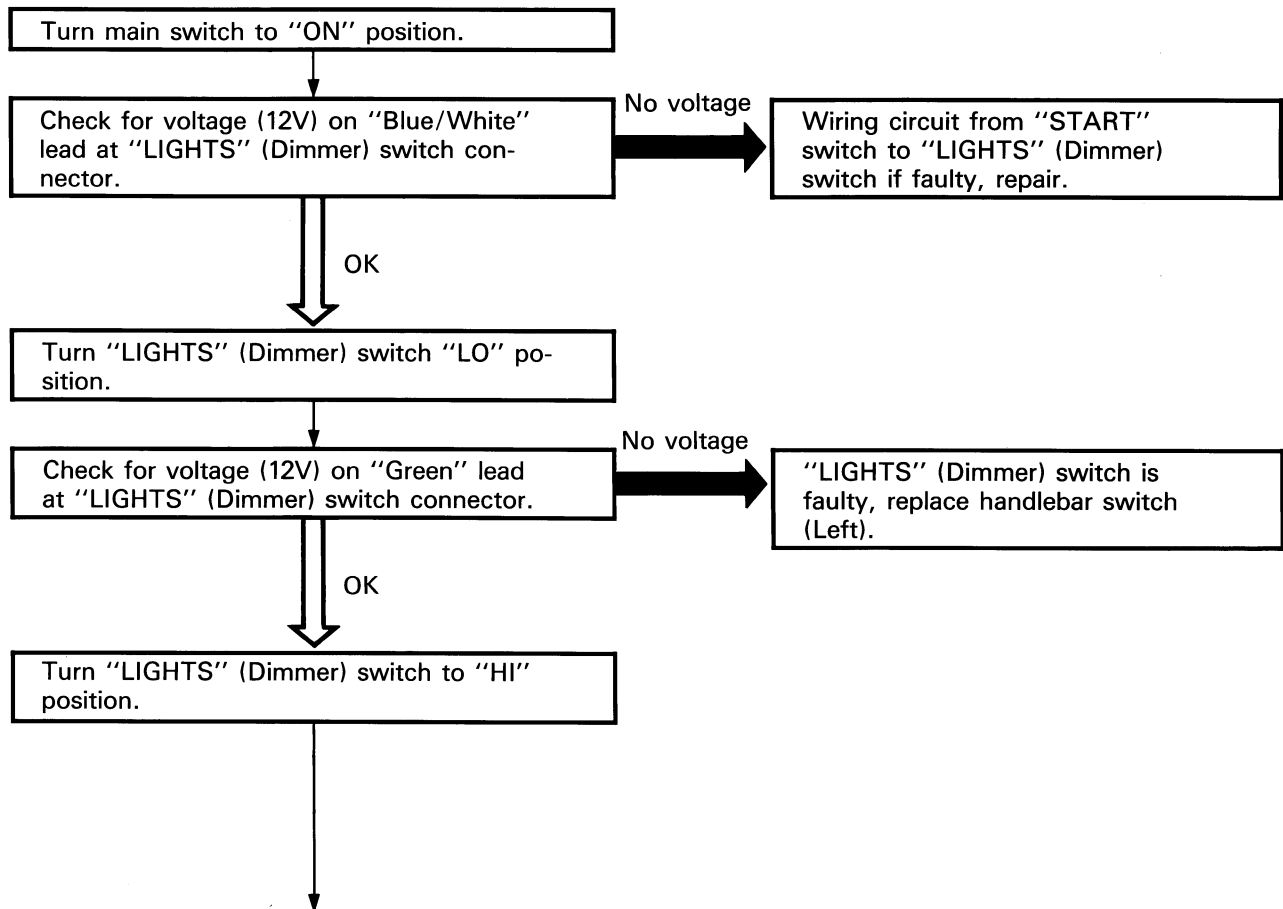

LIGHTING SYSTEM

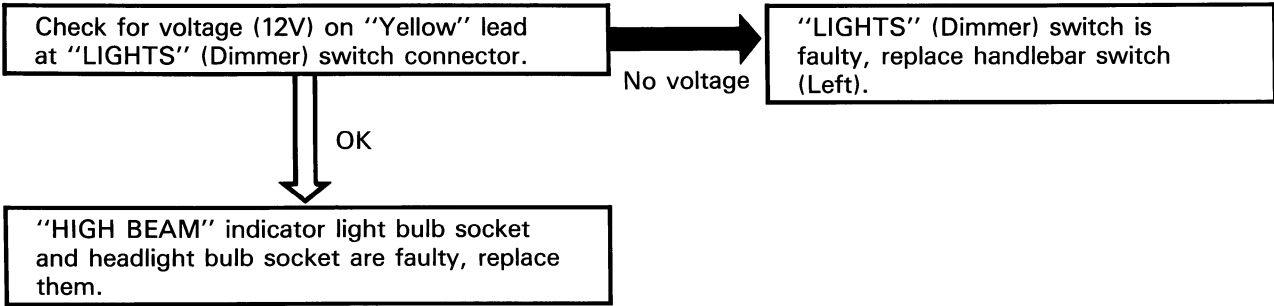

Meter lights do not come on.

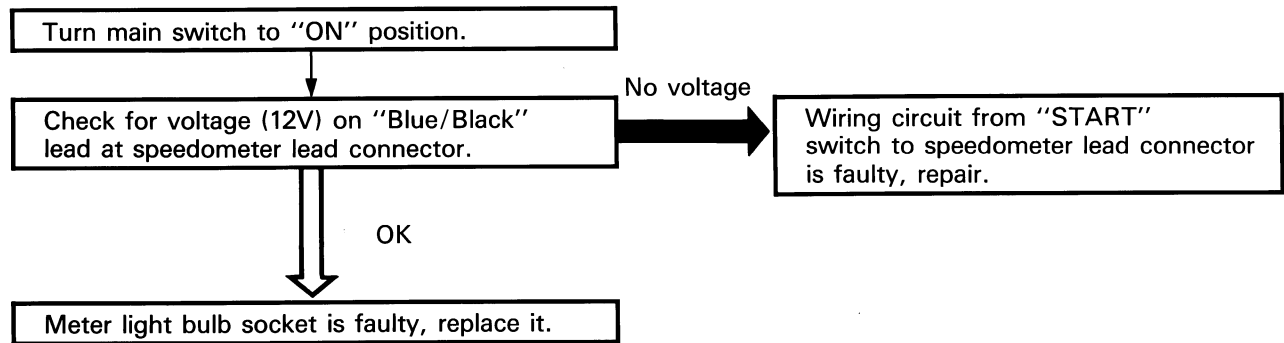

Taillight and/or license light do not come on.

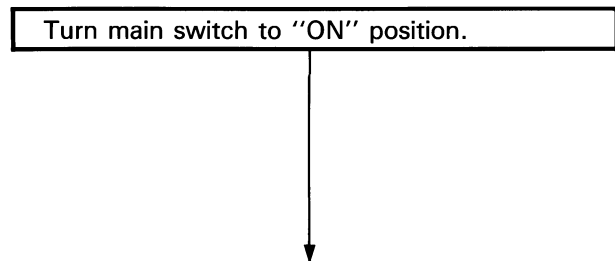

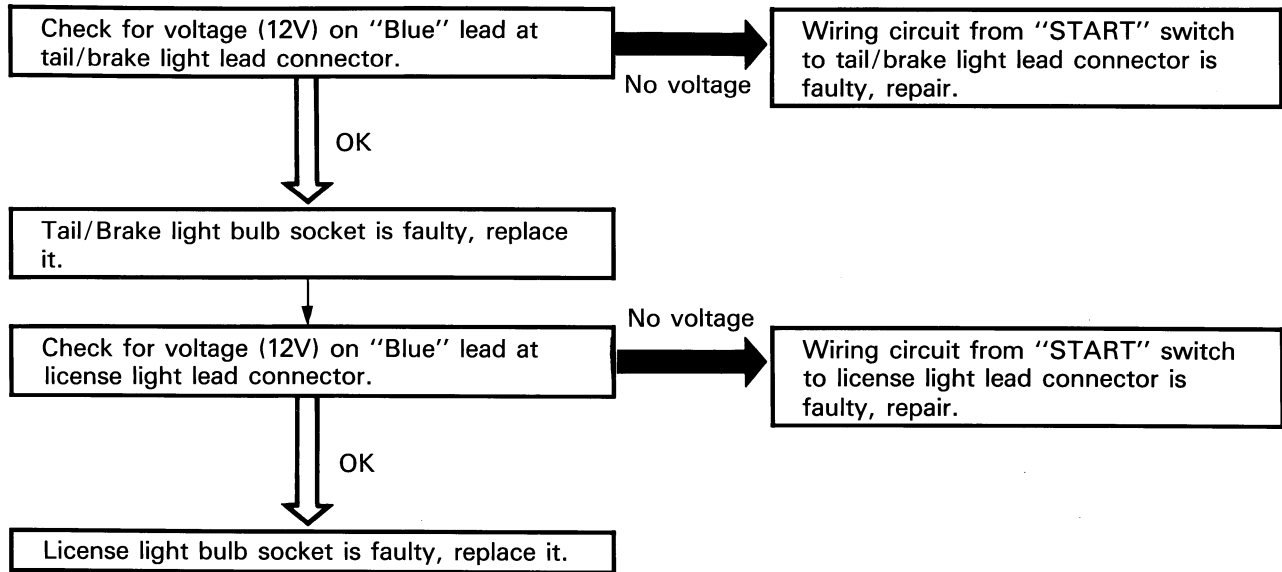

SIGNAL SYSTEM

CIRCUIT DIAGRAM

Below circuit diagram shows signal circuit.

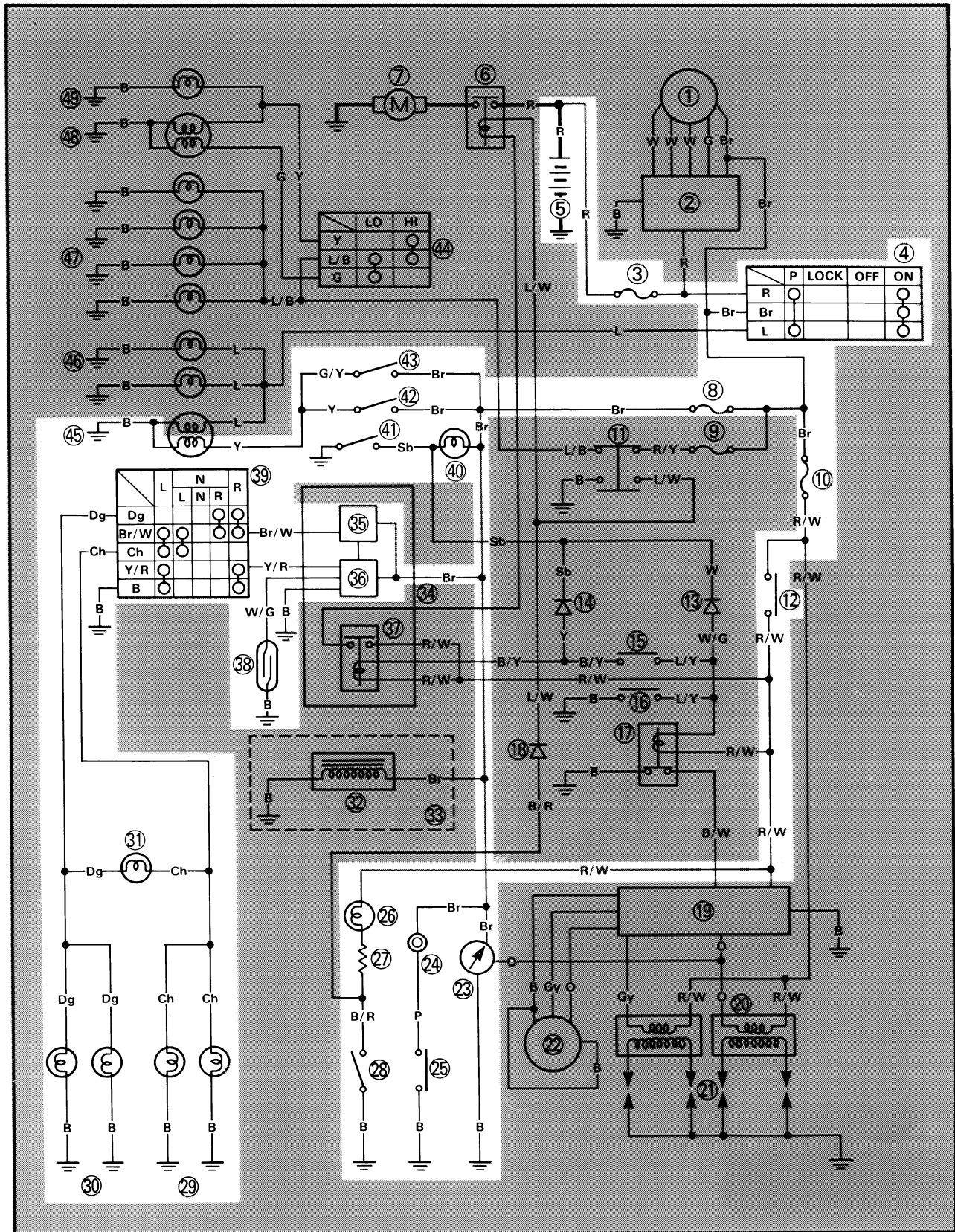



NOTE:

For the color codes, see page 6-2.

- | | |
|-------------------------|------------------------------|
| ③ Fuse (MAIN) | ③⑩ Flasher light (Right) |
| ④ Main switch | ③① "TURN" indicator light |
| ⑤ Battery | ③⑤ Flasher relay |
| ⑧ Fuse (SIGNAL) | (Included in relay assembly) |
| ⑩ Fuse (IGNITION) | ③⑥ Flasher cancelling unit |
| ⑫ "ENGINE STOP" switch | (Included in relay assembly) |
| ⑬ Tachometer | ③⑧ Reed switch |
| ⑭ Horn | ③⑨ "TURN" switch |
| ⑮ "HORN" switch | ④① "NEUTRAL" indicator light |
| ⑯ "OIL" indicator light | ④② Neutral switch |
| ⑰ Resistor | ④③ Rear brake switch |
| ⑱ Oil level switch | ④④ Front brake switch |
| ⑲ Flasher light (Left) | ④⑤ Tail/Brake light. |

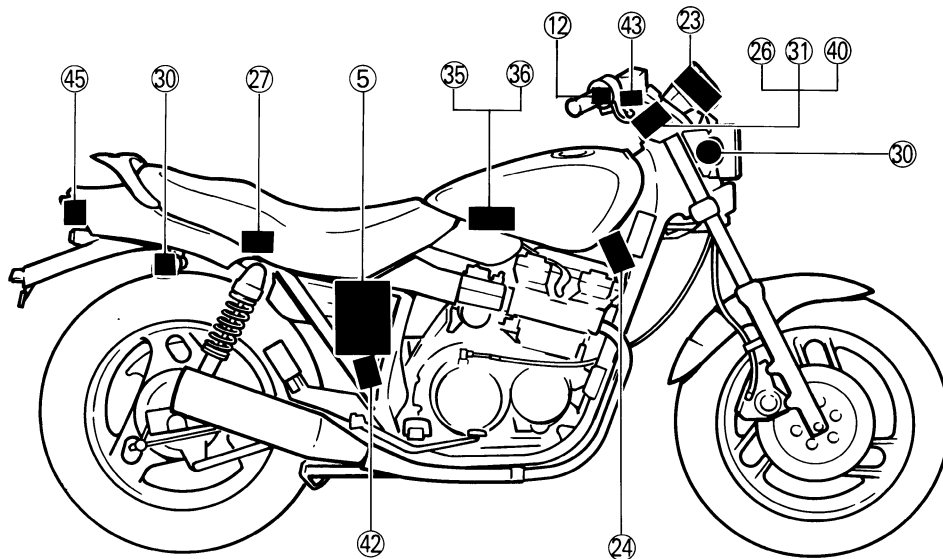
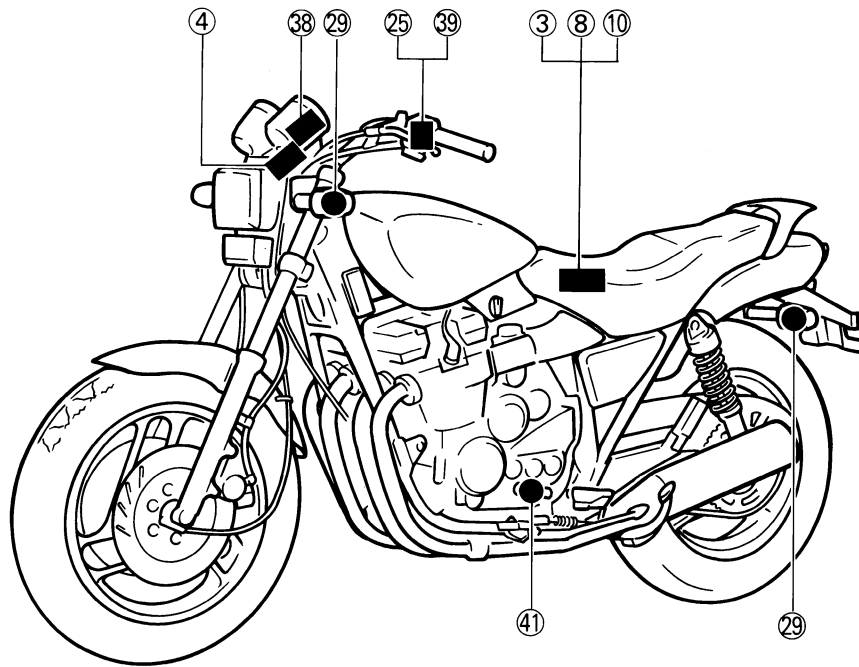



TROUBLESHOOTING

The battery provides power for operation of the signal system. If none of the above fail to operate proceed further. Low battery voltage indicates either a faulty battery, low battery fluid level, or a defective charging system.

Also check fuse condition.
Replace any "open" fuses.

Before this troubleshooting, remove following parts.

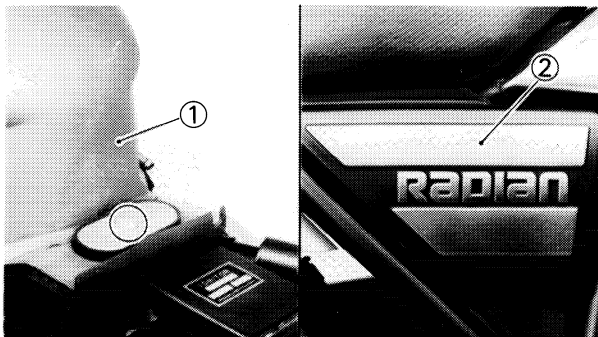

- Seat
- Fuel tank ①
- Side cover (Right) ②
- Headlight lens unit ③
- Cover (Front) ④

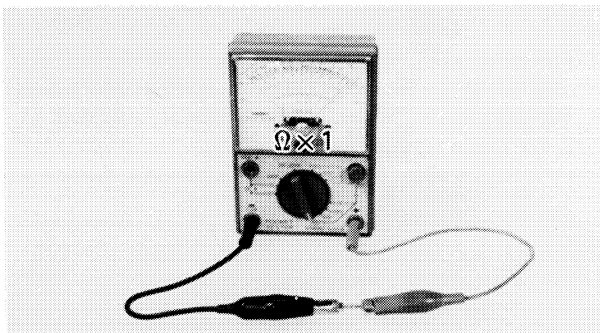
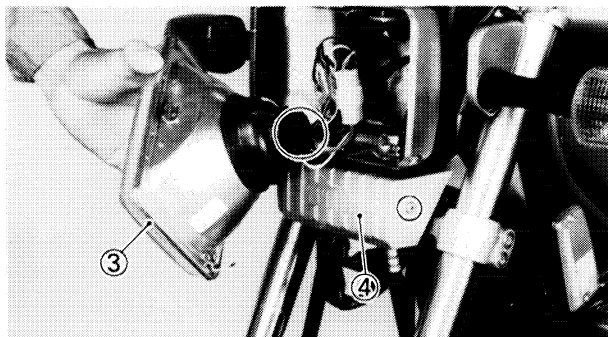

1. Fuse inspection

- Remove fuse (MAIN) fuse (IGNITION) and fuse (SIGNAL).
- Connect Pocket Tester (YU-03112) to fuse and check it for continuity.

NOTE:

Set tester selector to "Ω × 1" position.



Continuity.
(0Ω)

Discontinuity
(∞)

Replace fuse.



2. Battery fluid level inspection

- Fluid level should be between upper ① and lower ② level mark.

Correct

Incorrect

- Refill battery fluid.

CAUTION:

Refill with distilled water only; tap water contains minerals harmful to a battery.



3. Battery terminal inspection

- Inspect battery terminal and connections.

OK

Dirty or poor connection

- Clean battery terminals using wire brush.

NOTE:

After cleaning terminals, apply grease^① lightly to both terminals.

- Connect battery leads correctly.

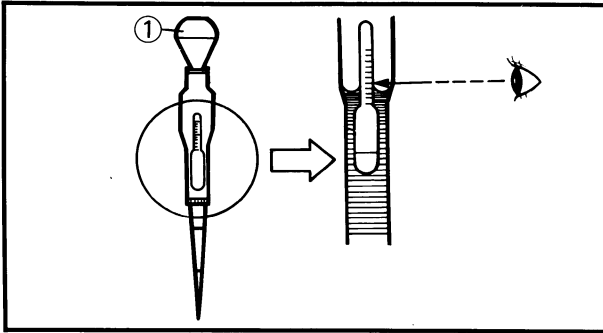

4. Battery fluid specific gravity inspection

- Remove caps.
- Inspect specific gravity of all cell using Battery Hydrometer ①.

Specific Gravity:

1.280 ± 0.01 at 20°C (68°F)

WARNING:

Battery electrolyte is poisonous and dangerous, causing severe burns, etc. It contains sulfuric acid. Avoid contact with skin, eyes or clothing. Antidote: **EXTERNAL**-Flush with water. **INTERNAL**-Drink large quantities of water or milk. Follow with milk of magnesia, beaten egg, or vegetable oil. Call a physician immediately.

Eyes: Flush with water for 15 minutes and get prompt medical attention. Batteries produce explosive gases. Keep sparks, flame, cigarettes etc., away. Ventilate when charging or using in an enclosed space. Always shield your eyes when working near batteries.

KEEP OUT OF REACH OF CHILDREN.

OK

Low specific gravity

- Recharge battery.

Charging Current:
1.2 amps/10 hrs

NOTE:

Replace the battery if:

- Battery voltage will not rise to a specific value or bubbles fail to rise even after many hours of charging.
- Sulfation of one or more cells occurs, as indicated by the plates turning white, or an accumulation of material exists in the bottom of the cell.



- Specific gravity readings after a long, slow charge indicate on cell to be lower than the rest.
- Warpage or buckling of plates or insulators is evident.

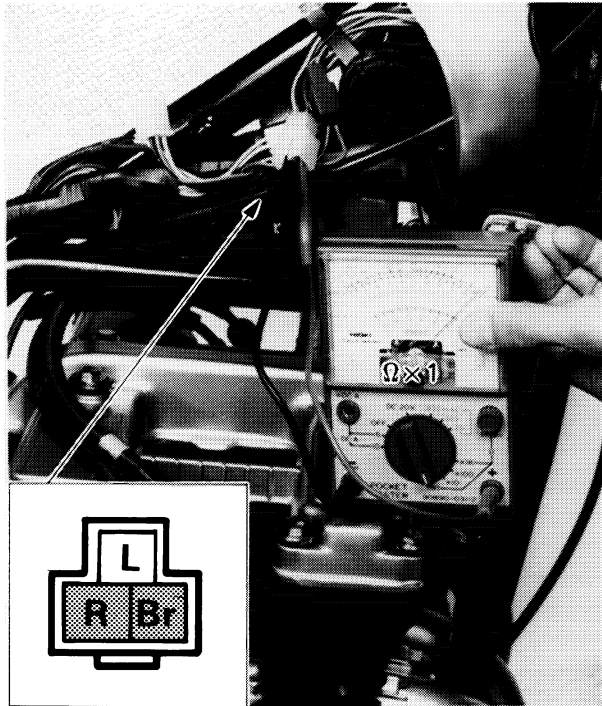

5. Main switch conduct check

- Disconnect main switch coupler (Brown, Red, Blue).
- Connect Pocket Tester (YU-03112) to main switch leads.

Tester (+) lead → Red lead
 Tester (-) lead → Brown lead

NOTE:

Set tester selector to " $\Omega \times 1$ " position.

- Turn main switch to "ON" position and check it for continuity.

Continuity
(0 Ω)

Discontinuity
(∞)

Main switch is faulty, replace it.

6. Check entire signal system for connections.
 Refer to "WIRING DIAGRAM" section.

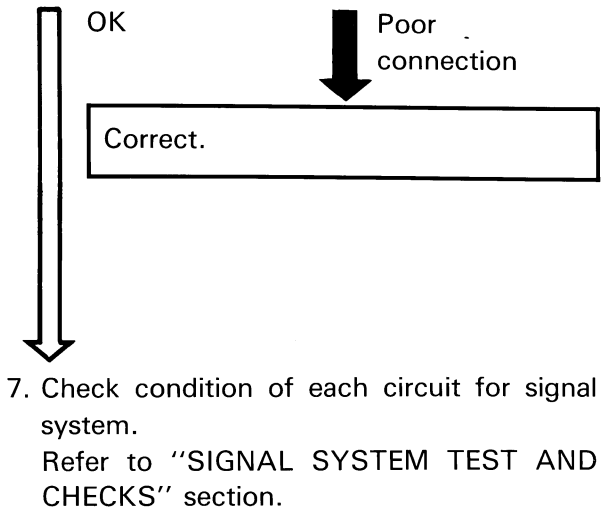

SIGNAL SYSTEM TEST AND CHECKS

Horn does not work.

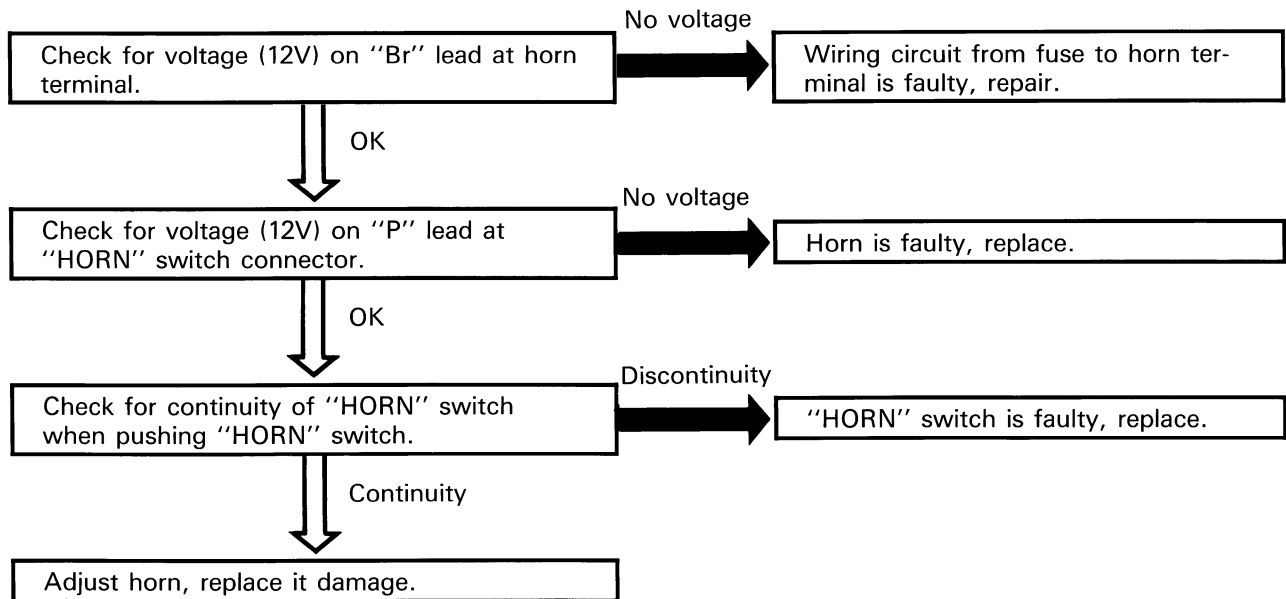



Brake light does not work.

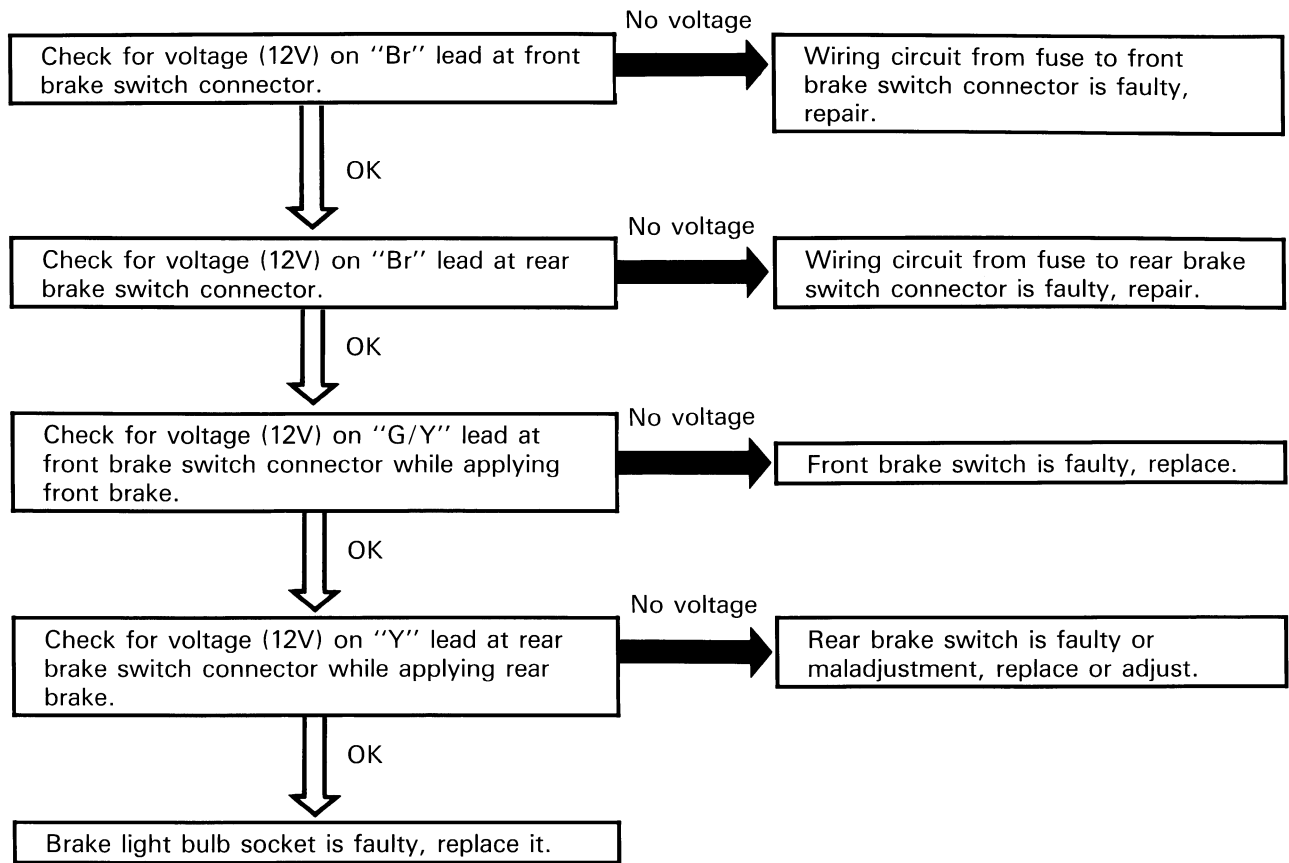

"NEUTRAL" indicator light does not come on

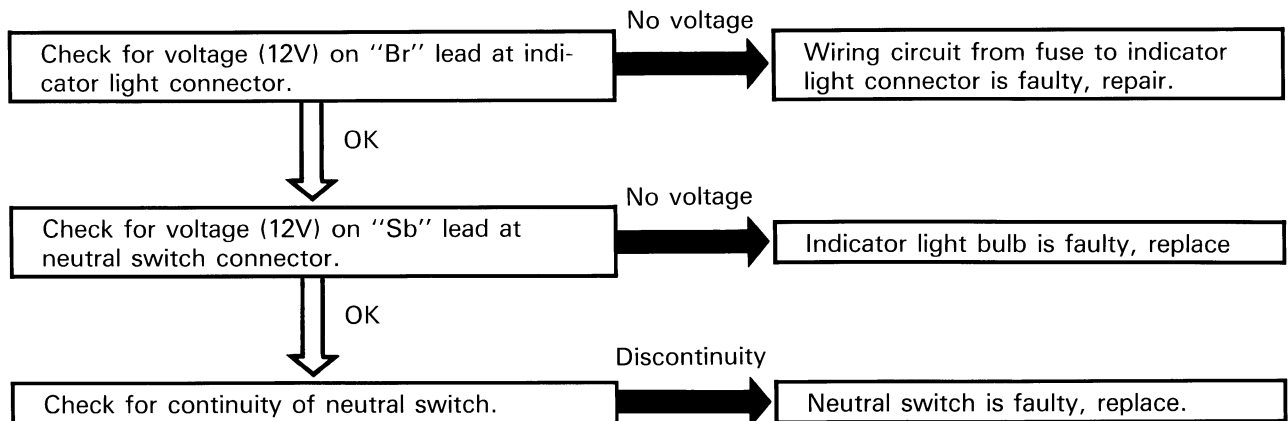



Flasher lights (left and/or right) do not come on.

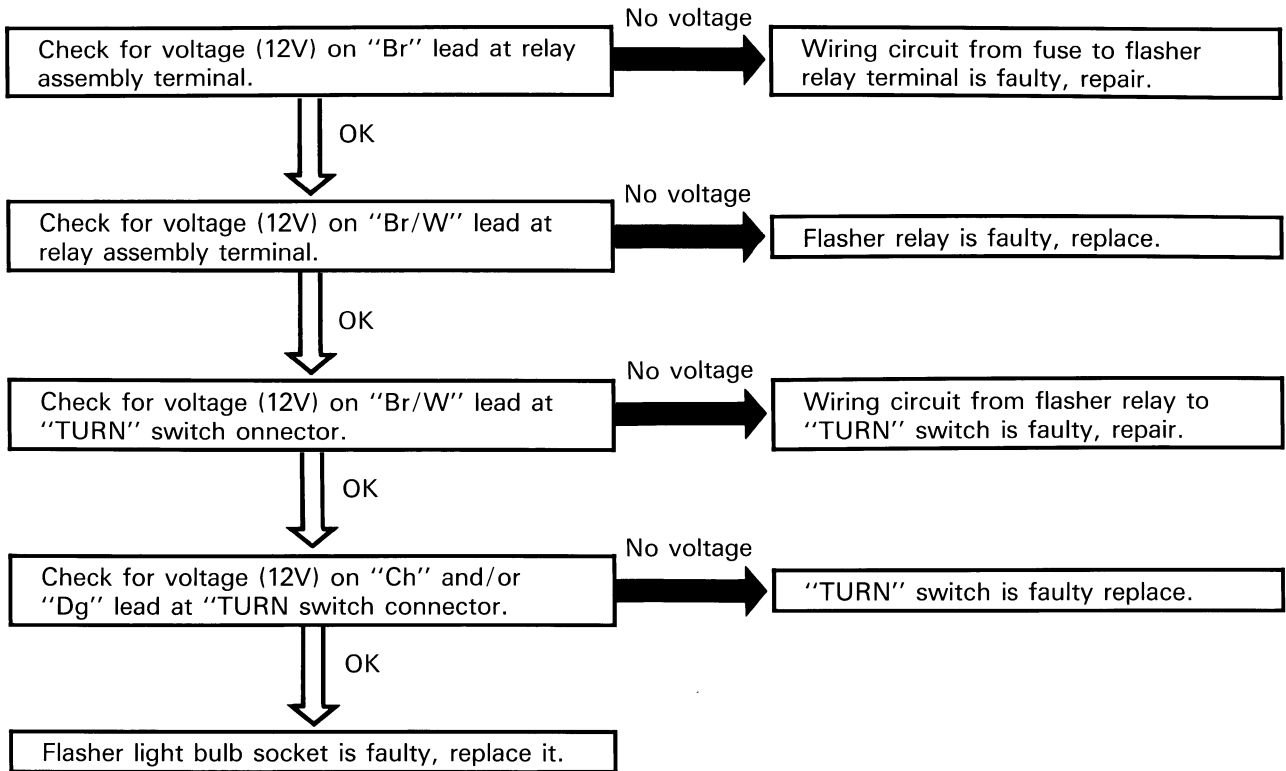

"OIL" indicator light does not come on.

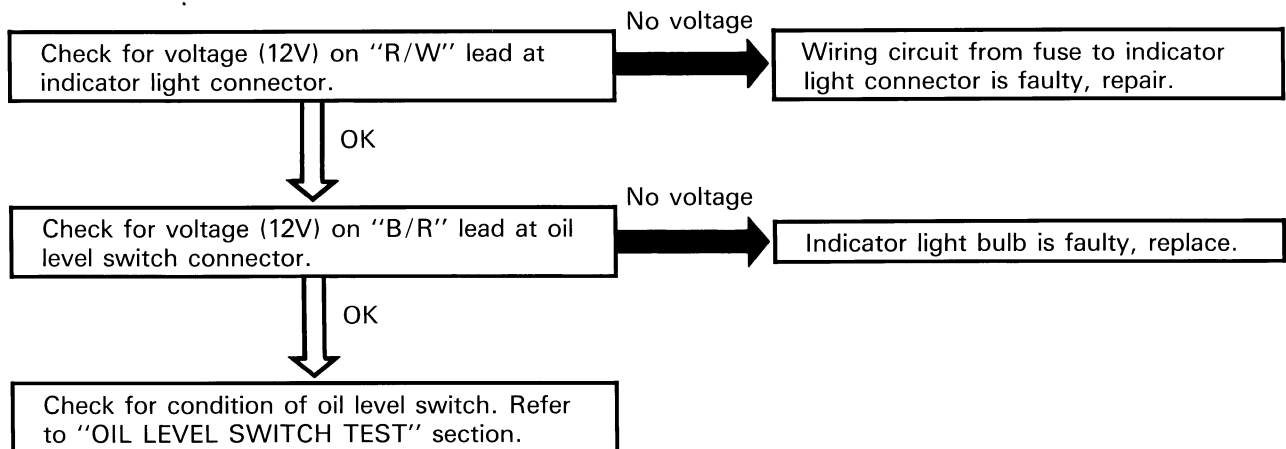

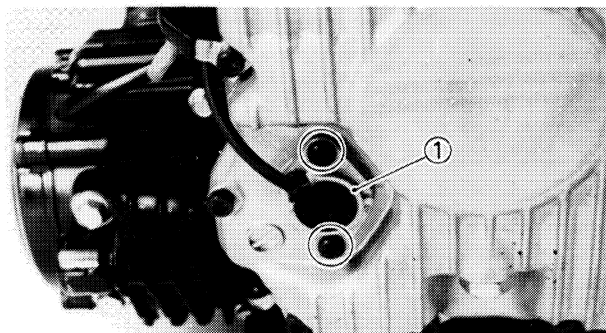
**OIL LEVEL SWITCH TEST**

1. Remove:
 - Mufflers
 - Oil level switch ①

2. Connect the Pocket Tester (YU-03112).

Tester (+) lead → Oil level switch lead
Tester (-) lead → Oil level switch base

NOTE:

Set the tester selector to " $\Omega \times 1$ " position.

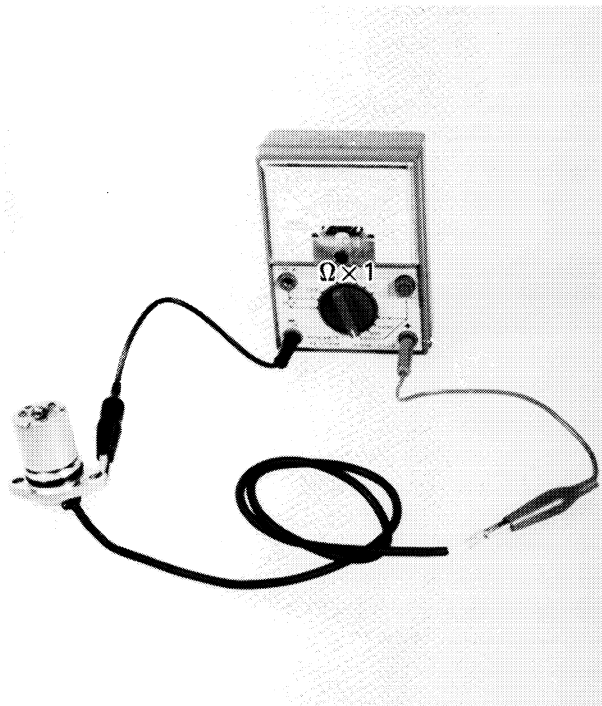

3. Check
 - Oil level switch
 - Upside-down position.
Continuity → Replace.
 - Upright position.
Discontinuity → Replace.

CARBURETOR AIR VENT SYSTEM (CALIFORNIA ONLY)

CIRCUIT DIAGRAM

Below circuit diagram shows carburetor air vent circuit.

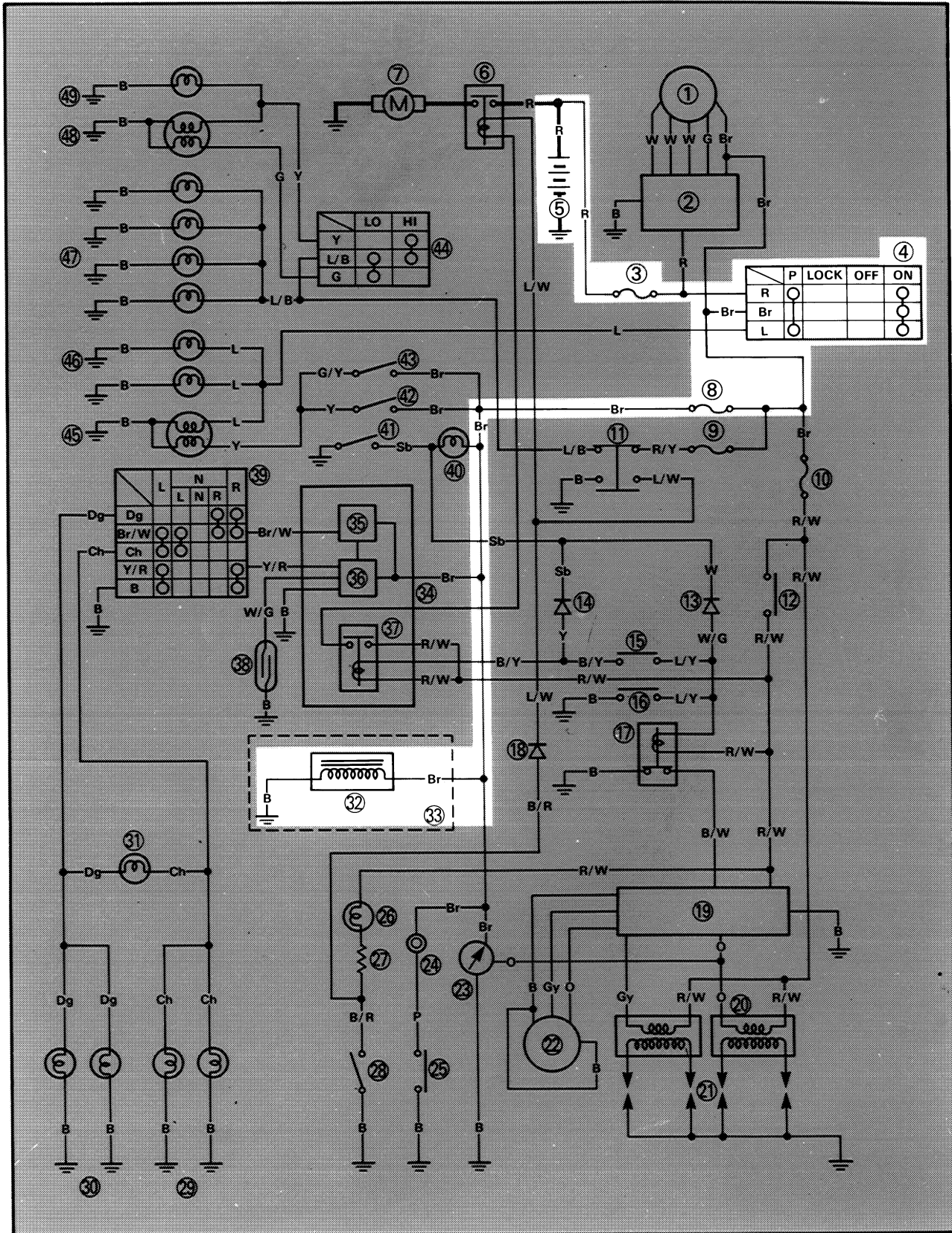

CARBURETOR AIR VENT SYSTEM

ELEC



NOTE: _____

For the color codes, see page 6-2.

- ③ Fuse (MAIN)
- ④ Main switch
- ⑤ Battery
- ⑧ Fuse (SIGNAL)
- ⑩ Air vent control valve
- ⑩ California only

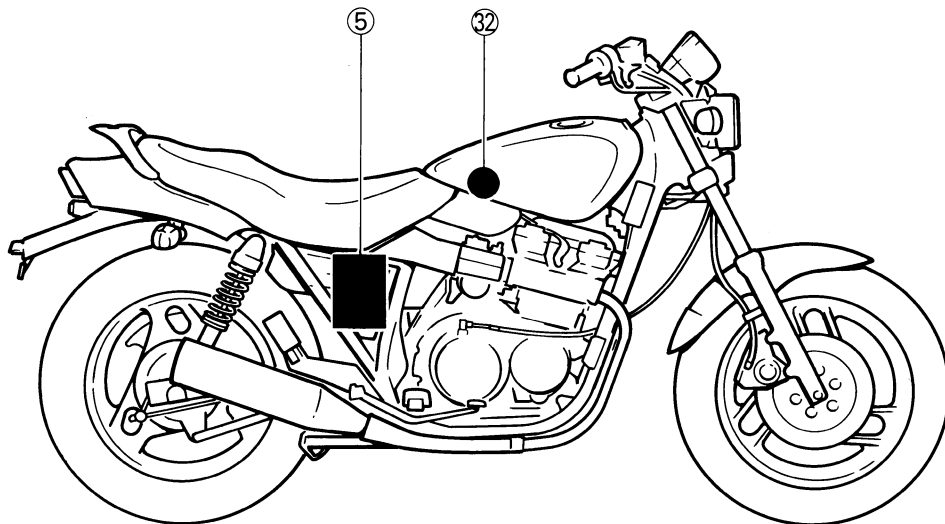
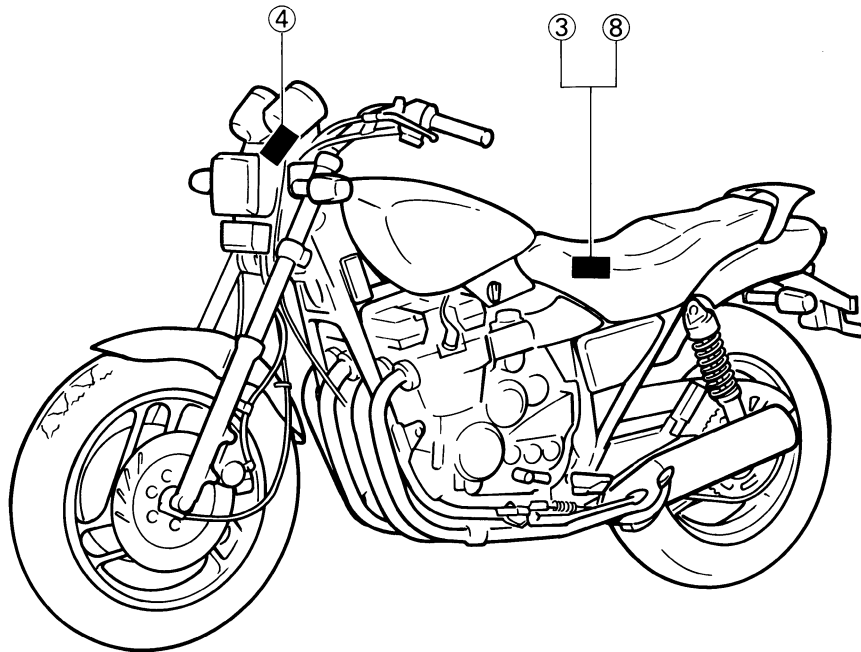

6



DESCRIPTION

This model is equipped with a canister to prevent the discharging of fuel vapor and carburetor air vent into the atmosphere.

OPERATION

The carburetor air vent is controlled by the air vent control valve when the main switch is turned to "ON" position.

- ① Fuel tank
- ② Air vent control valve
- ③ Carburetor
- ④ Canister
- ⑤ Roll over valve
- ⑥ Nozzle

← Main switch is turned to "OFF"

⇐ Main switch is turned to "ON"

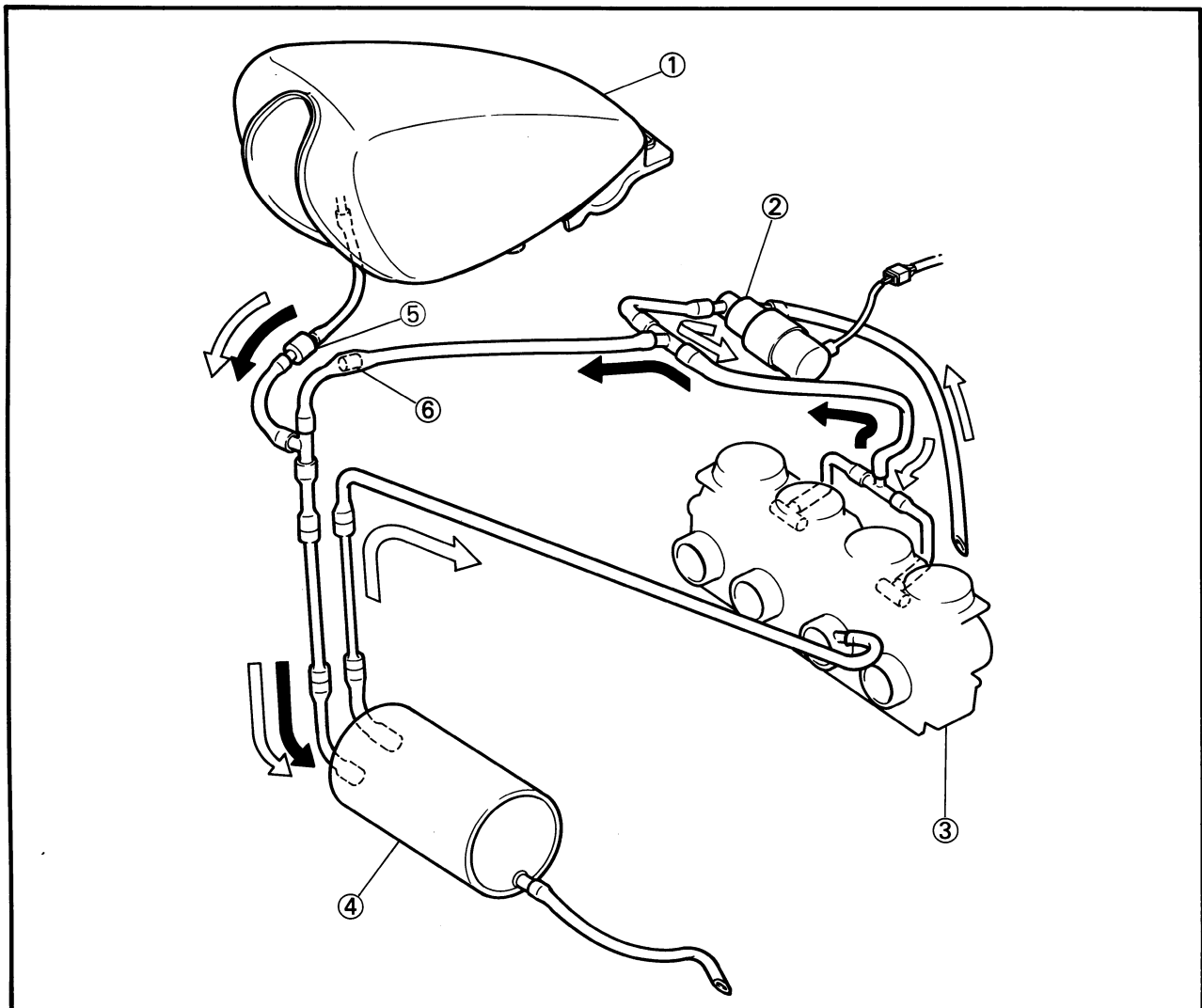



TROUBLESHOOTING

The battery provides power for operation of the air vent control valve. If none of the above fail to operate proceed further. Low battery voltage indicates either a faulty battery, low battery fluid level, or a defective charging system.

Also check fuse condition. Replace any "open" fuses.

Before this troubleshooting, remove the following parts.

- Seat
- Fuel tank ①

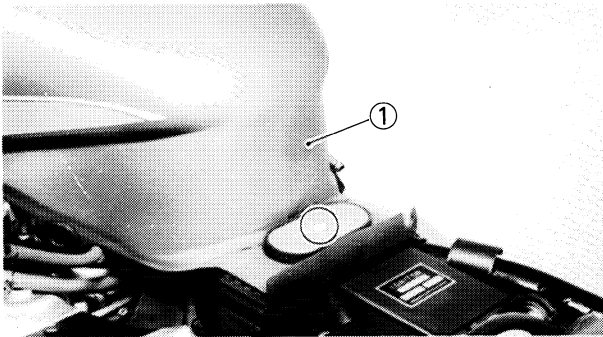

THE AIR VENT CONTROL VALVE DOES NOT OPERATE (THE ENGINE LOSES POWER).

1. Check hose connection.

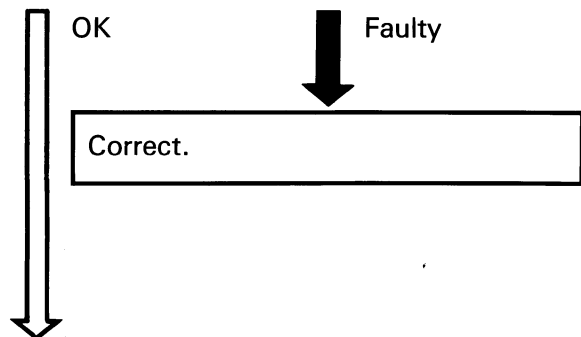
6

2. Check hose for clogging.

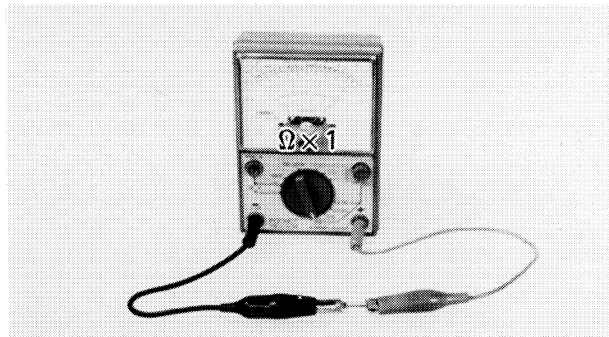
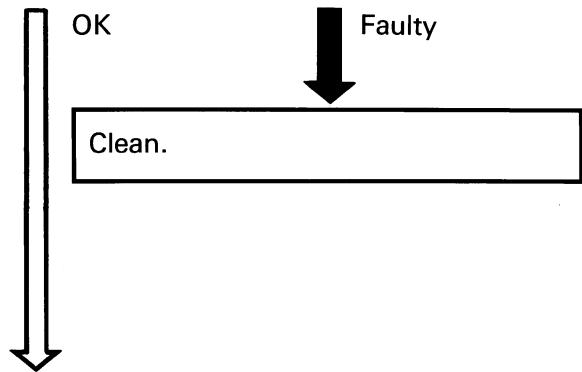

3. Fuse inspection

- Remove fuse (MAIN) and fuse (SIGNAL).
- Connect Pocket Tester (YU-03112) to fuse and check it for continuity.

NOTE: _____

Set tester selector to " $\Omega \times 1$ " position.

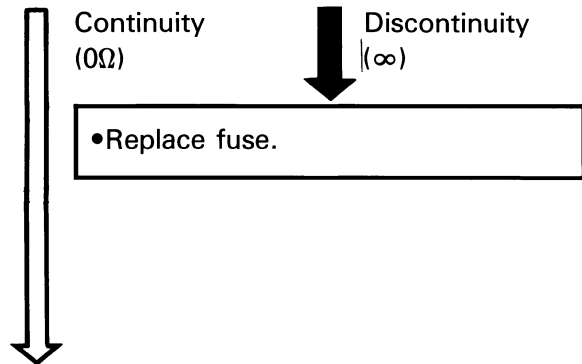

4. Battery fluid level inspection

- Fluid level should be between upper ① and lower ② level mark.

CARBURETOR AIR VENT SYSTEM

ELEC



Correct

Incorrect

- Refill battery fluid.

CAUTION: _____

Refill with distilled water only; tap water contains minerals harmful to a battery.

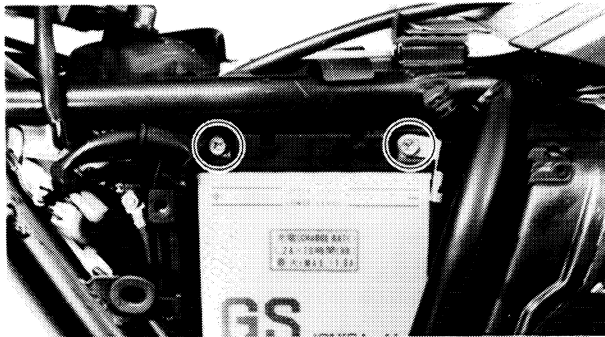

5. Battery terminal inspection

- Inspect battery terminal and connections.

OK

Dirty or poor connection

- Clean battery terminals using wire brush.

NOTE: _____

After cleaning terminals, apply grease lightly to both terminals.

- Connect battery leads correctly.

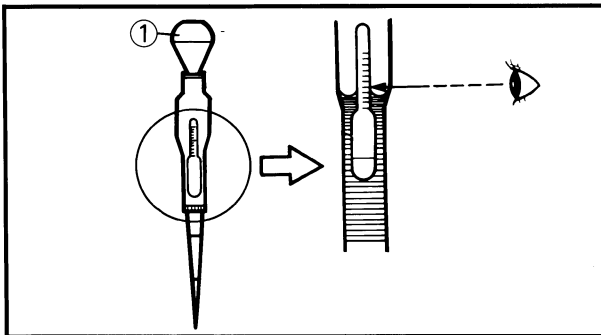

6. Battery fluid specific gravity inspection

- Remove caps.
- Inspect specific gravity of all cell using Battery Hydrometer ①.

Specific Gravity:

1.280 ± 0.01 at 20°C (68°F)



WARNING: _____

Battery electrolyte is poisonous and dangerous, causing severe burns, etc. It contains sulfuric acid. Avoid contact with skin, eyes or clothing. Antidote: EXTERNAL-Flush with water. INTERNAL-Drink large quantities of water or milk. Follow with milk of magnesia, beaten egg, or vegetable oil. Call a physician immediately.

6



CARBURETOR AIR VENT SYSTEM

Eyes: Flush with water for 15 minutes and get prompt medical attention. Batteries produce explosive gases. Keep sparks, flame, cigarettes etc., away. Ventilate when charging or using in an enclosed space. Always shield your eyes when working near batteries.

KEEP OUT OF REACH OF CHILDREN.

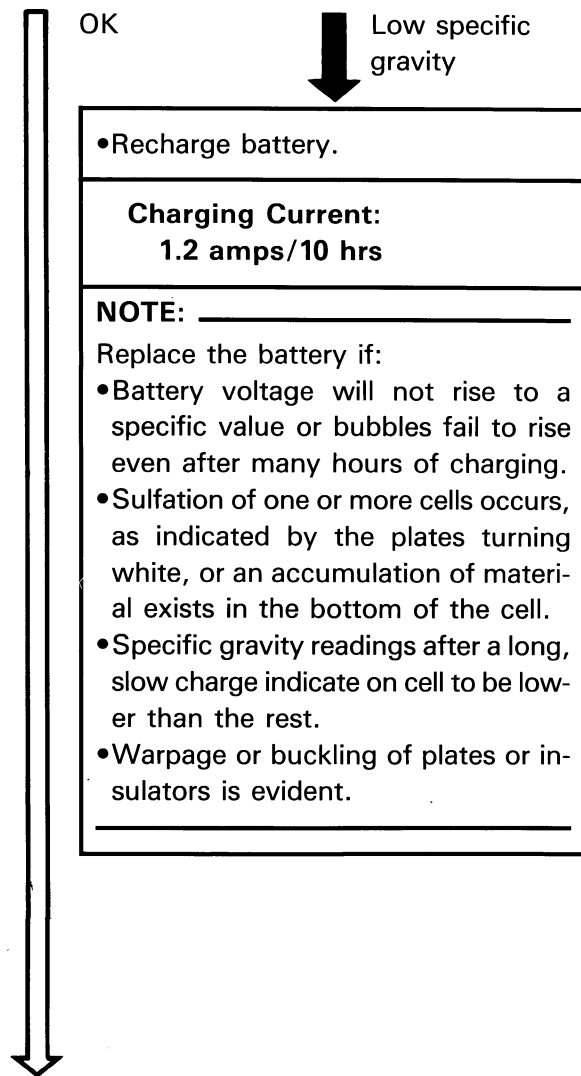

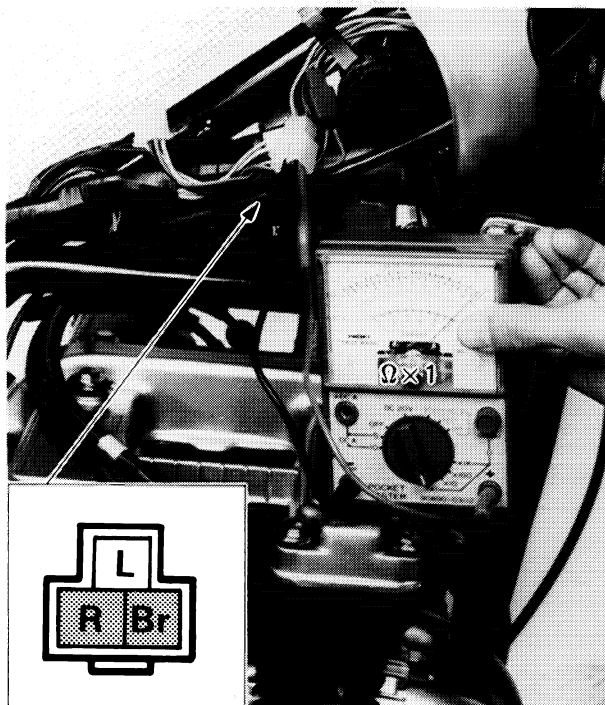

9. Main switch conduct check

- Disconnect main switch coupler (Brown, Red, Blue lead).
- Connect Pocket Tester (YU-03112) to main switch leads (Brown, Red).

Tester (+) lead → Red lead
Tester (-) lead → Brown lead

NOTE:

Set tester selector to " $\Omega \times 1$ " position.

- Turn main switch to "ON" position and check it for continuity.

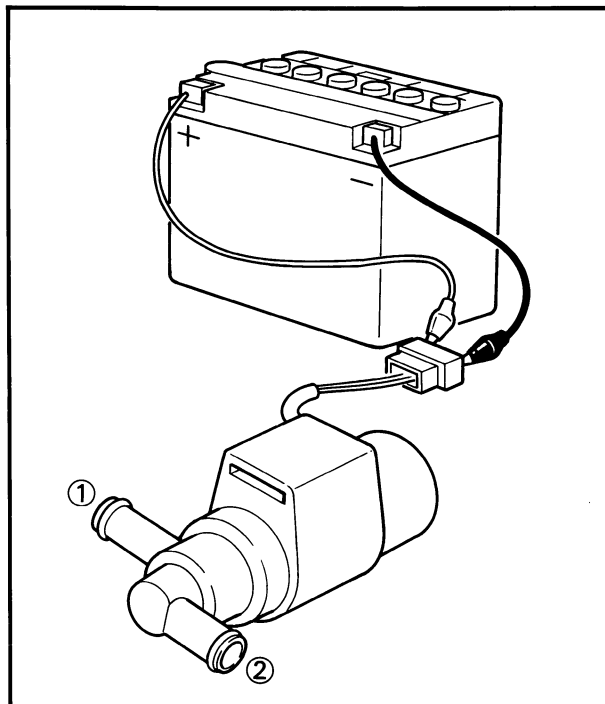
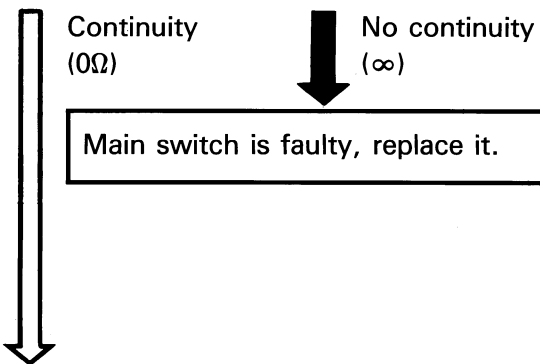

10. Air vent control valve test

- Remove air vent control valve.
- Connect 12V battery to air vent control valve as shown.
- Blow air inside at nozzle ① which is open to atmosphere.
- Check for air escape at nozzle ② on canister side.
 No air escape → Valve is faulty.
 Air escape → Valve is good.
- Disconnect battery and blow air inside at nozzle ① which is open to atmosphere.
- Check for air escape at nozzle ② on canister side.
 Air escape → Valve is faulty.
 No air escape → Valve is good.

CARBURETOR AIR VENT SYSTEM

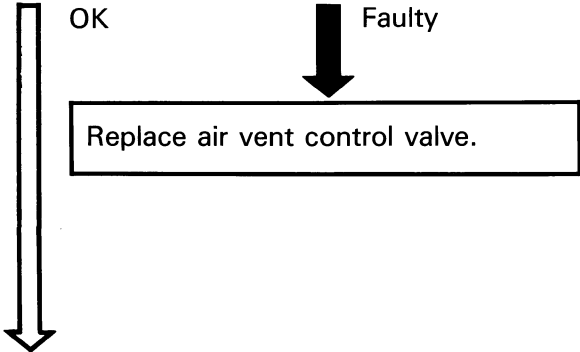

11. Check entire air vent control valve system for connections.
Refer to "WIRING DIAGRAM" section.

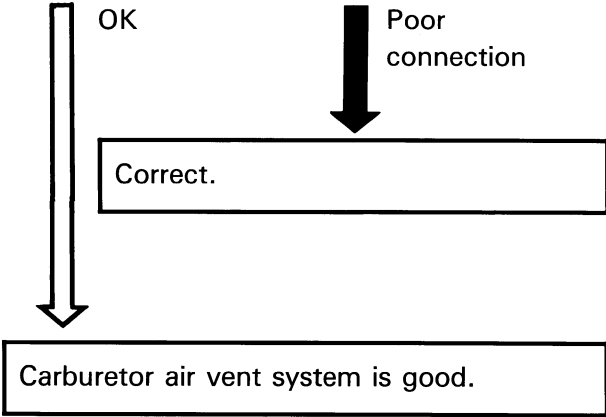

**CHAPTER 7
APPENDICES**

SPECIFICATIONS7-1
 GENERAL SPECIFICATIONS7-1
 MAINTENANCE SPECIFICATIONS7-4

GENERAL TORQUE SPECIFICATIONS7-18

DEFINITION OF UNITS7-19

CONVERSION TABLES7-19

LUBRICATION DIAGRAM7-20

CABLE ROUTING7-22

YX600S/YX600SC WIRING DIAGRAM



APPENDICES

SPECIFICATIONS

GENERAL SPECIFICATIONS

Model	YX600S/YX600SC
Model Code Number:	1UJ (For YX600S) 1UL (For YX600SC)
Vehicle Identification Number:	JYA1UJ00*GA000101 (For YX600S) JYA1UL00*GA000101 (For YX600SC)
Engine Starting Number:	1UJ-000101 (For YX600S) 1UL-000101 (For YX600SC)
Dimensions:	
Overall Length	2,075 mm (81.7 in)
Overall Width	770 mm (30.3 in)
Overall Height	1,095 mm (43.1 in)
Seat Height	765 mm (30.1 in)
Wheelbase	1,385 mm (54.5 in)
Minimum Ground Clearance	145 mm (5.7 in)
Basic Weight:	
With Oil and Full Fuel Tank	197 kg (434 lb)
Minimum Turning Radius:	2,400 mm (94.5 in)
Engine:	
Engine Type	Air cooled 4-stroke, gasoline, DOHC
Cylinder Arrangement	4-cylinder parallel
Displacement	599 cm ³
Bore × Stroke	58.5 × 55.7 mm (2.3 × 2.19 in)
Compression Ratio	10.0 : 1
Compression Pressure	1078.8 kPa (11 kg/cm ² , 156.4 psi)
Starting System	Electric starter
Lubrication System:	Pressure lubricated, wet sump
Engine Oil Type or Grade:	
	Yamalube 4-cycle oil or SAE 20W40 type SE motor oil SAE 10W30 type SE motor oil
Engine Oil Capacity:	
Engine Oil:	
Periodic Oil Change:	2.2 L (1.9 Imp qt, 2.3 US qt)
With Oil Filter Replacement	2.5 L (2.2 Imp qt, 2.6 US qt)
Total Amount	2.9 L (2.6 Imp qt, 3.0 US qt)
Air Filter	Dry type element

GENERAL SPECIFICATIONS

APPX



Model	YX600S/YX600SC	
Fuel: Type Tank Capacity Reserve Amount	Regular gasoline 12.0 L (2.6 Imp gal, 3.2 US gal) 2.5 L (0.55 Imp gal, 0.66 US gal)	
Carburetor: Type (Quantity) Manufacturer	BS30 (4 pcs.) MIKUNI	
Spark plug: Type (Manufacture) Gap	D8EA (N.G.K.), X24ESU (N.D.) 0.6~0.7 mm (0.024~0.028 in)	
Clutch Type:	Wet, multiple-disc	
Transmission: Primary Reduction System Primary Reduction Ratio Secondary Reduction System Secondary Reduction Ratio Transmission Type Operation Gear Ratio	Spur gear, HY-VO chain 22/21×65/28 (2.431) Chain drive 45/16 (2.813) Constant-mesh, 6-speed Left foot operation 1st 41/15 (2.733) 2nd 37/19 (1.947) 3rd 34/22 (1.545) 4th 31/25 (1.240) 5th 29/28 (1.036) 6th 27/30 (0.900)	
Chassis: Frame Type Caster Angle Trail	Tubular steel, double cradle 27° 128 mm (5.04 in)	
Tire:	Front	Rear
Type Size Manufacture (Type)	Tubeless 110/90-16 59H DUNLOP (K355F) BRIDGESTONE (G527)	Tubeless 130/90-16 67H DUNLOP (K355) BRIDGESTONE (G528)
Tire Pressure (Cold tire):	Front	Rear
Up to 90 kg (198 lb) load*	177 kPa (1.8 kg/cm ² , 26 psi)	196 kPa (2.0 kg/cm ² , 28 psi)
90 kg (198 lb)~160 kg (353 lb) load*	196 kPa (2.0 kg/cm ² , 28 psi)	226 kPa (2.3 kg/cm ² , 32 psi)
160 kg (353 lb)~Maximum load*	196 kPa (2.0 kg/cm ² , 28 psi)	245 kPa (2.5 kg/cm ² , 36 psi)
High speed riding	196 kPa (2.0 kg/cm ² , 28 psi)	226 kPa (2.3 kg/cm ² , 32 psi)

*Load is total weight of cargo, rider, passenger, and accessories.



Model	YX600S/YX600SC
Brake: Front Brake Type Operation Rear Brake Type Operation	Dual disc brake Right hand operation Drum brake Right foot operation
Suspension: Front Suspension Rear Suspension	Telescopic fork Swingarm
Shock Absorber: Front Shock Absorber Rear Shock Absorber	Coil spring, oil damper Coil spring, oil damper
Wheel Travel: Front Wheel Travel Rear Wheel Travel	140 mm (5.5 in) 98 mm (3.9 in)
Electrical: Ignition System Generator System Battery Type or Model Battery Capacity	T.C.I. (Full Transistor ignition) A.C. generator 12N12A-4A 12V 12AH
Headlight Type:	Bulb (Quartz bulb)
Bulb Wattage (Quantity): Headlight Tail/Brake Light Flasher Light License Light Meter Light	60W/55W (1 pcs.) 8W/27W (1 pcs.) 27W (4 pcs.) 3.8W (2 pcs.) 3.4W (4 pcs.)
Indicator Light: Wattage (Quantity) "NEUTRAL" "HIGH BEAM" "TURN" "OIL LEVEL"	3.4W (1 pcs.) 3.4W (1 pcs.) 3.4W (1 pcs.) 3.4W (1 pcs.)



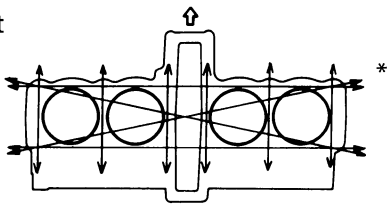
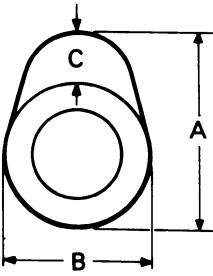
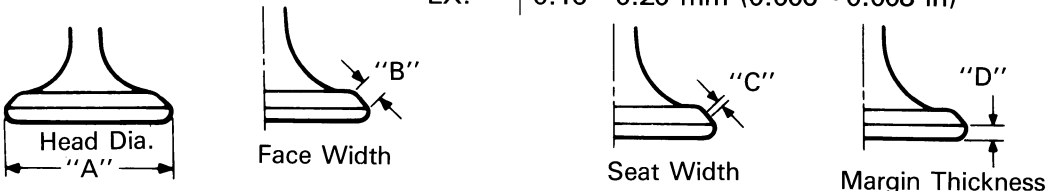

MAINTENANCE SPECIFICATIONS
Engine

Model	YX600S/YX600SC
<p>Cylinder Head: Warp Limit</p> 	<p>0.03 mm (0.001 in) *Lines indicate straightedge measurement.</p>
<p>Cylinder: Bore Size Taper Limit Out-of-round Limit</p>	<p>58.50 mm (2.303 in) 0.05 mm (0.002 in) 0.01 mm (0.0004 in)</p>
<p>Camshaft: Drive Method Cam Cap Inside Diameter (Cylinder head direct support) Camshaft Outside Diameter Shaft-to-cap Clearance Cam Dimensions: Intake "A" < Limit > "B" < Limit > "C" < Limit > Exhaust "A" < Limit > "B" < Limit > "C" < Limit > Camshaft Runout Limit Cam Chain Type/Number of Links Cam Chain Adjustment Method</p> 	<p>Chain drive (Center) 25^{+0.021} mm (0.9449^{+0.0008} in) 25^{-0.020} mm (0.9448^{-0.0008} in) 0.020 ~ 0.054 mm (0.0008 ~ 0.0021 in) 36.25 ~ 36.35 mm (1.427 ~ 1.431 in) 36.2 mm (1.43 in) 28.1 ~ 28.2 mm (1.106 ~ 1.11 in) 28.05 mm (1.1 in) 8.3 mm (0.327 in) 8.1 mm (0.319 in) 35.75 ~ 35.85 mm (1.408 ~ 1.411 in) 35.7 mm (1.41 in) 28.05 ~ 28.15 mm (1.104 ~ 1.108 in) 28 mm (1.1 in) 7.8 mm (0.307 in) 7.6 mm (0.299 in) 0.05 mm (0.002 in) Bush-chain/114 Manual</p>
<p>Valve, Valve Seat, Valve Guide: Valve Clearance (Cold) IN. EX.</p> 	<p>0.11 ~ 0.15 mm (0.004 ~ 0.006 in) 0.16 ~ 0.20 mm (0.006 ~ 0.008 in)</p>



Model		YX600S/YX600SC
"A" Head Dia.	IN.	31 ^{+0.4} mm (1.220 ^{+0.0236} in)
	EX.	27 ± 0.1 mm (1.063 ± 0.004 in)
"B" Face Width	IN.	2.26 mm (0.0889 in)
	EX.	2.26 mm (0.0889 in)
"C" Seat Limit Width	IN.	1.0 ± 0.1 mm (0.0394 ± 0.004 in)
	EX.	1.0 ± 0.1 mm (0.0394 ± 0.004 in)
"D" Margin Thickness Limit	IN.	1.0 ± 0.2 mm (0.0394 ± 0.008 in)
	EX.	1.0 ± 0.2 mm (0.0394 ± 0.008 in)
Stem Outside Diameter	IN.	5.975 ~ 5.990 mm (2.2352 ~ 0.2358 in)
	EX.	5.960 ~ 5.975 mm (0.2346 ~ 0.2352 in)
Guide Inside Diameter	IN.	6.0 ~ 6.012 mm (0.2362 ~ 0.2367 in)
	EX.	6.0 ~ 6.012 mm (0.2362 ~ 0.2367 in)
Stem-to-guide Clearance	IN.	0.010 ~ 0.037 mm (0.0004 ~ 0.0015 in)
	EX.	0.025 ~ 0.052 mm (0.0010 ~ 0.0020 in)
Stem Runout Limit		0.03 mm (0.001 in)
Valve Seat Width	IN.	0.9 ~ 1.1 mm (0.0390 ~ 0.0398 in)
	EX.	0.9 ~ 1.1 mm (0.0390 ~ 0.0398 in)
< Limit >	IN.	2.0 mm (0.08 in)
	EX.	2.0 mm (0.08 in)
Valve Spring:		
Free Length		
Inner Spring	IN.	35.5 mm (1.398 in)
	EX.	35.5 mm (1.398 in)
Outer Spring	IN.	37.2 mm (1.465 in)
	EX.	37.2 mm (1.465 in)
Installed Length (Valve Closed)		
Inner Spring	IN.	30.5 mm (1.201 in)
	EX.	30.5 mm (1.201 in)
Outer Spring	IN.	32.0 mm (1.260 in)
	EX.	32.0 mm (1.260 in)
Tilt Limit		
Inner Spring	IN. & EX.	2.5°/1.5 mm (0.063 in)
Outer Spring	IN. & EX.	2.5°/1.6 mm (0.063 in)

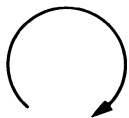

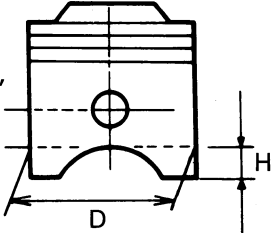
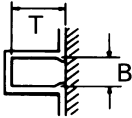
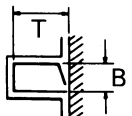
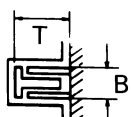
Model		YX600S/YX600SC	
Direction of Winding (Top View)	Inner spring	Outer spring	
	IN. and EX.	IN. and EX.	
	Clockwise	Counter clockwise	
			
Piston: Piston Size "D" Measuring Point "H"		58.50 mm (2.30 in) 7.0 mm (0.276 in) (From bottom line of piston skirt)	
Clearance Between Piston & Cylinder Oversize:	1st 2nd 3rd 4th	0.025~0.045 mm (0.0010~0.0018 in) — 59.00 mm (2.32 in) — 60.00 mm (2.36 in)	
Piston Ring: Sectional Sketch	Top Ring	Barrel B = 1.0 mm (0.039 in) T = 2.3 mm (0.090 in)	
	2nd Ring	Taper B = 1.2 mm (0.047 in) T = 2.3 mm (0.090 in)	
	Oil Ring	Expander B = 2.5 mm (0.10 in) T = 2.8 mm (0.11 in)	
	End Gap (Installed):	Top Ring < Limit > 2nd Ring < Limit > Oil Ring	0.15~0.30 mm (0.0059~0.0118 in) 0.7 mm (0.0276 in) 0.15~0.30 mm (0.0059~0.0118 in) 0.7 mm (0.0276 in) 0.2~0.7 mm (0.0079~0.0276 in)
Side Clearance:	Top Ring < Limit > 2nd Ring < Limit > Oil Ring	0.03~0.07 mm (0.0012~0.0028 in) 0.15 mm (0.0059 in) 0.02~0.06 mm (0.0008~0.0024 in) 0.15 mm (0.0059 in) —	

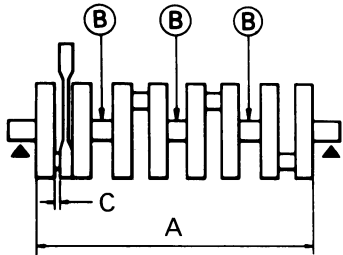

Model	YX600S/YX600SC
Connecting Rod: Oil Clearance Color Code	0.016 ~ 0.040 mm (0.0006 ~ 0.0016 in) 1. Blue 2. Black 3. Brown 4. Green
Crankshaft:  Crank Width "A" Runout Limit "B" Big End Side Clearance "C" Crank Journal Oil Clearance Color Code	312.4 ± 0.6 mm (12.30 ± 0.024 in) 0.03 mm (0.0012 in) 0.16 ~ 0.262 mm (0.006 ~ 0.010 in) 0.021 ~ 0.044 mm (0.0008 ~ 0.0017 in) 1. Blue 2. Black 3. Brown 4. Green 5. Yellow
Clutch: Friction Plate Thickness/Quantity Wear Limit Clutch Plate Thickness/Quantity Warp Limit Clutch Spring Free Length/Quantity Clutch Spring Minimum Length Clutch Release Method	3.0 ± 0.1 mm (0.12 ± 0.0039 in)/8 pcs 2.7 mm (0.106 in) 1.6 ± 0.1 mm (0.063 ± 0.0039 in)/7 pcs. 0.15 mm (0.0059 in) 42.8 mm (1.690 in)/5 pcs. 41.8 mm (1.646 in) Outer Pull, Rack & Pinion Pull
Transmission: Main Axle Deflection Limit Drive Axle Deflection Limit	0.08 mm (0.0031 in) 0.08 mm (0.0031 in)
Shifter: Shifter Type	Guide bar
Carburetor: Type/Manufacture/Quantity I.D. Mark Main Jet (M.J.) Main Air Jet (M.A.J.) Jet Needle-clip Position (J.N.) (For No.1 and 4 Cylinder) (For No.2 and 3 Cylinder)	BS30/MIKUNI/4 pcs. 1UJ00 (For YX600S), 1UL00 (For YX600SC) #97.5 #140 4CHP2 4CHP4



Model	YX600S/YX600SC	
Needle Jet	(N.J.)	0-6 (517)
Pilot Jet	(P.J)	# 30
Pilot Outlet Size	(P.O.)	ø0.8
Pilot Air Jet	(P.A.J)	# 135
Pilot Screw	(P.S.)	Preset
Valve Seat Size	(V.S.)	ø2.3
Starter Jet	(G.S ₁)	# 25
	(G.S ₂)	ø0.6
	(B.P ₁)	ø0.9
Bypass Size	(B.P ₂)	ø0.8
	(B.P ₃)	ø0.8
Fuel Level	(F.L.)	2.0±0.5 mm (0.08±0.02 in) Below from the carburetor mixing chamber body edge
Float Height		20±1.0 mm (0.8±0.04 in)
Engine Idling Speed		1,300±50 r/min
Vacuum Pressure at Idling Speed		23.3±0.667 kPa (175±5 mmHg, 6.890±0.1969 inHg)
Vacuum Synchronous Difference		Below 10 kPa (10 mmHg, 0.4 inHg)
Lubrication System:		
Oil Filter Type		Paper
Oil Pump Type		Trochoid pump
Tip Clearance		0.09~0.15 mm (0.0035~0.0060 in)
< Limit >		< 0.2 mm (0.008 in) >
Side Clearance		0.03~0.08 mm (0.0012~0.0031 in)
< Limit >		< 0.15 mm (0.006 in) >
Bypass Valve Setting Pressure		98.0±20 kPa (1.0±0.2 kg/cm ² , 14.2±2.8 psi)
Relief Valve Operating Pressure		490±49 kPa (5.0±0.5 kg/cm ² , 71.1±7.1 psi)

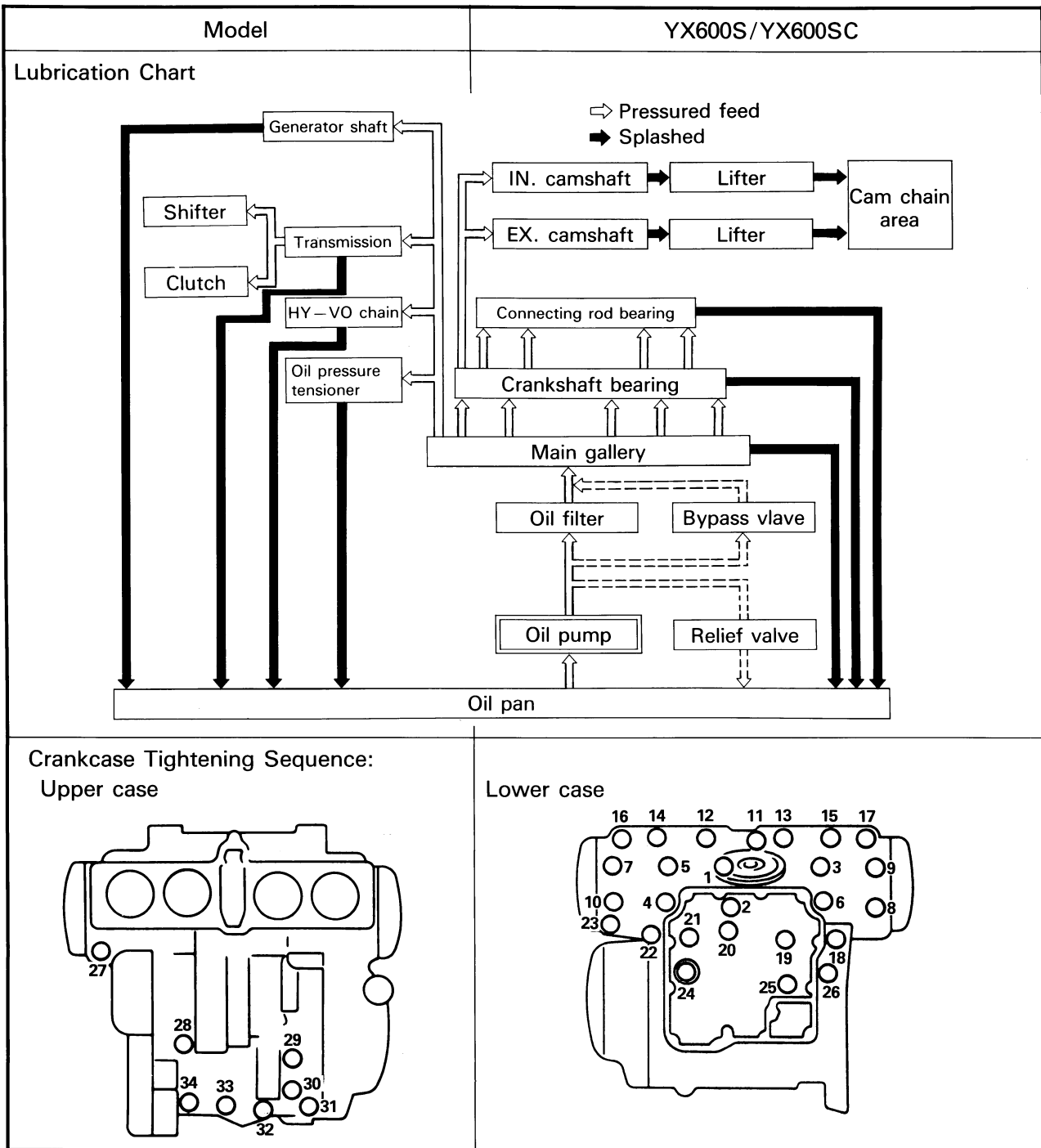

MAINTENANCE SPECIFICATIONS

APPX



Part to be tightened	Part name	Thread size	Q'ty	Tightening torque			Remarks
				Nm	m•kg	ft•lb	
Cam shaft cap	Bolt	M6 P1.0	24	10	1.0	7.2	Tighten in 3-stages
Cylinder (cam chain)	Stud bolt	M6 P1.0	4	5	0.5	3.6	Apply oil
Cylinder head (Exhaust pipe)	Stud bolt	M6 P1.0	8	10	1.0	7.2	Apply oil
Cylinder head	Stud bolt	M6 P1.0	4	5	0.5	3.6	Apply oil
Cylinder	Nut	M8 P1.25	1	20	2.0	14	
Cylinder	Nut	M6 P1.0	1	10	1.0	7.2	
Cylinder head	Cap nut	M8 P1.25	12	22	2.2	16	Apply oil
Spark plug		M12 P1.25	4	17.5	1.75	13	
Cylinder head cover	Bolt	M6 P1.0	12	10	1.0	7.2	
Cylinder	Stud bolt	M8 P1.25	1	15	1.5	11	Apply oil
Cylinder and crankcase	Nut	M8 P1.25	1	20	2.0	14	
Connecting rod and rod cap	Nut	M7 P0.75	8	25	2.5	18	
Camshaft and sprocket	Bolt	M7 P1.0	4	24	2.4	17	
Cam chain tensioner stopper bolt	Bolt	M8 P1.0	1	8	0.8	5.7	
Cam chain tensioner case and cylinder	Bolt	M6 P1.0	1	10	1.0	7.2	
Cam chain tensioner case and cylinder	Nut	M6 P1.0	1	10	1.0	7.2	
Cam chain tensioner lock nut	Nut	M8 P1.25	1	9	0.9	6.5	
Crankcase	Plug	M10 P1.25	1	10	1.0	7.2	
Rotor housing and pump cover	Screw	M6 P1.0	1	7	0.7	5.1	
Oil pump ass'y and crankcase	Screw	M6 P1.0	3	7	0.7	5.1	
Strainer housing and crankcase	Bolt	M6 P1.0	2	10	1.0	7.2	
Strainer cover and crankcase	Bolt	M6 P1.0	12	10	1.0	7.2	
Filter cover and crankcase	Union bolt	M20 P1.5	1	15	1.5	11	
Drain bolt	Plug	M14 P1.5	1	43	4.3	31	
Carburetor joint and cylinder head	Bolt	M6 P1.0	8	10	1.0	7.2	

MAINTENANCE SPECIFICATIONS



Part to be tightened	Part name	Thread size	Q'ty	Tightening torque			Remarks
				Nm	m•kg	ft•lb	
Oil level gauge switch	Bolt	M6 P1.0	2	7	0.7	5.1	
Relief valve and crankcase	—		1	20	2.0	14	
HY-VO chain tensioner	Bolt	M6 P1.0	2	10	1.0	7.2	Use LOCTITE®
Primary drive gear	Nut	M16 P1.5	1	50	5.0	36	
Bearing cover plate	Screw	M6 P1.0	2	10	1.0	7.2	Use LOCTITE®
Starter clutch	Bolt	M8 P1.25	3	25	2.5	18	Use LOCTITE®
Shift shaft stopper	Screw	M8 P1.25	1	22	2.2	16	
Shift cam bearing plate	Screw	M6 P1.0	1	10	1.0	7.2	



Chassis

Model	YX600S/YX600SC												
Steering System: Steering Bearing Type No./Size of Steel Balls: <table style="display: inline-table; vertical-align: middle;"> <tr> <td style="padding-right: 10px;">Upper</td> <td></td> </tr> <tr> <td>Lower</td> <td></td> </tr> </table>	Upper		Lower		Ball Bearing 19 pcs/1/4 in 19 pcs/1/4 in								
Upper													
Lower													
Front Suspension: Front Fork Travel Fork Spring Free Length Spring Rate/Stroke Optional Spring Oil Capacity Oil Grade	140 mm (5.5 in) 542 mm (21.3 in) $K_1 = 3.8 \text{ N/mm (0.385 kg/mm, 21.2 lb/in)}$ 0.0 ~ 95 mm (0.0 ~ 3.47 in) $K_2 = 5.6 \text{ N/mm (0.575 kg/mm, 31.7 lb/in)}$ 95 ~ 140 mm (3.74 ~ 5.51 in) No 320 cm ³ (11.3 Imp oz, 10.8 US oz) Yamaha Fork Oil 10WT or equivalent												
Rear Suspension: Shock Absorber Travel Spring Free Length Spring Rate/Stroke Optional Spring Adjustment <table style="display: inline-table; vertical-align: middle;"> <tr> <td style="padding-right: 10px;">Spring Position</td> <td></td> <td></td> <td></td> <td></td> <td></td> </tr> </table>	Spring Position						80 mm (3.1 in) 222.4 mm (8.76 in) $K_1 = 17.6 \text{ N/mm (1.8 kg/mm, 99.1 lb/in)}$ 0.0 ~ 52 mm (0.0 ~ 2.04 in) $K_2 = 25.5 \text{ N/mm (2.6 kg/mm, 143.2 lb/in)}$ 52 ~ 80 mm (2.04 ~ 3.15 in) No						
Spring Position													
	← Stiffer			Std.	Softer								
	5	4	3	2	1								
Rear Arm: Swingarm Free Play Limit (End)	1.0 mm (0.039 in)												
Wheel: Front Wheel Type Rear Wheel Type Front Rim Size/Material Rear Rim Size/Material Rim Runout Limit <table style="display: inline-table; vertical-align: middle;"> <tr> <td style="padding-right: 10px;">Vertical</td> <td></td> </tr> <tr> <td>Lateral</td> <td></td> </tr> </table>	Vertical		Lateral		Cast Wheel Cast Wheel MT2.50 × 16/ Aluminum MT3.00 × 16/ Aluminum 2.0 mm (0.08 in) 2.0 mm (0.08 in)								
Vertical													
Lateral													
Drive Chain: Type/Manufacturer No. of Links Chain Free Play	50HDL2/DAIDO 104 20 ~ 30 mm (0.78 ~ 1.18 in)												
Front Disc Brake: Type Outside Dia. × Thickness Pad Thickness: <table style="display: inline-table; vertical-align: middle;"> <tr> <td style="padding-right: 10px;">Inner</td> <td></td> </tr> <tr> <td>< Limit > *</td> <td></td> </tr> <tr> <td>Outer</td> <td></td> </tr> <tr> <td>< Limit > *</td> <td></td> </tr> </table>	Inner		< Limit > *		Outer		< Limit > *		Dual disc 267 × 5 mm (10.5 × 0.2 in) 5.5 mm (0.21 in) 0.5 mm (0.019 in) 5.5 mm (0.21 in) 0.5 mm (0.019 in)				
Inner													
< Limit > *													
Outer													
< Limit > *													

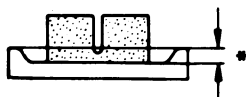

MAINTENANCE SPECIFICATIONS

APPX



Model	YX600S/YX600SC
Master Cylinder Inside Dia. Caliper Cylinder Inside Dia. Brake Fluid Type	15.87 mm (0.62 in) 42.8 mm (1.50 in) DOT #3
Rear Drum Brake: Type Brake Drum Inside Diameter < Limit > Lining Thickness < Limit > Shoe Spring Free Length	Leading, Trailing 180 mm (7.08 in) < 181 mm (7.12 in) > 4 mm (0.16 in) < 2 mm (0.08 in) > 68 mm (2.68 in)
Brake Lever & Brake Pedal: Brake Lever Free Play (at lever end) Brake Pedal Free Play Brake Pedal Position	2 ~ 5 mm (0.08 ~ 0.20 in) 20 ~ 30 mm (0.8 ~ 0.12 in) 15 mm (0.6 in) (Vertical height below footrest top)
Clutch Lever Free Play (at lever end):	10 ~ 15 mm (0.4 ~ 0.6 in)



Electrical

Model	YX600S/YX600SC
Voltage	12V
Ignition System:	
Ignition Timing (B.T.D.C.)	10° ± 1° at 1,200 r/min
Advancer Type	Electrical
T.C.I.:	
Pickup Coil Resistance	108 ~ 132Ω at 20°C (68°F)
(Color)	(Black—Gray) (Black—Orange)
T.C.I. Unit—Manufacturer	TID14-31 HITACHI
Ignition Coil	
Model/Manufacturer	CM12-10/HITACHI
Minimum Spark Gap	6 mm (0.24 in) or more at 500 r/min
Primary Winding Resistance	2.43 ~ 2.97Ω at 20°C (68°F)
Secondary Winding Resistance	10.56 ~ 15.84KΩ at 20°C (68°F)
Spark Plug Cap Resistance	10KΩ
Charging System:	
Type	A.C. Generator
A.C. Generator:	
Model/Manufacturer	LD117-13/HITACHI
Nominal Output	14V, 17A at 5,000 r/min
Field Coil Resistance	2.7 ~ 3.3Ω at 20°C (68°F) (Brown—Green)
Starter Coil Resistance	0.5 ~ 0.6Ω at 20°C (68°F) (White—White)
Brush—Overall Length	17 mm (0.669 in)
< Limit >	10 mm (0.394 in)
— Spring Force	190 ~ 360 gr (6.7 ~ 12.7 oz)
Voltage Regulator:	
Type	Field control
Model/Manufacturer	SH233-12/SHINDENGEN
No Load Regulated Voltage	14.2 ~ 14.8V
Rectifier:	
Model/Manufacturer	SH233-12/SHINDENGEN
Capacity	15A
Withstand Voltage	300V



Model	YX600S/YX600SC
Battery: Capacity Specific Gravity	12V 12AH 1.280
Electrical Starter System: Type Starter Motor: Model/Manufacturer Output Armature Coil Resistance Brush—Overall Length < Limit > — Spring Force Commutator Dia. Wear Limit Mica Undercut Starter Relay: Model/Manufacturer Amperage Rating Coil Resistance	Constant mesh type SM8204/MITSUBA 0.5 kw 0.012Ω ± 10% at 20°C (68°F) 12 mm (0.47 in) 5 mm (0.20 in) 340 ~ 460 g (12.0 ~ 16.2 oz) 28 mm (1.10 in) 27 mm (1.06 in) 1.6 mm (0.06 in) 22U-00/HONDA LOCK 150A 3.4Ω at 20°C (68°F)
Horn: Type/Quantity Model/Manufacturer Maximum Amperage	Plane Type/1 pcs. YF-12./NIKKO 2.5A
Flasher Relay (Relay Assembly): Type Model/Manufacturer Self Cancelling Device Flasher Frequency Wattage	Semi transistor type FX257N/NIPPON DENSO Yes 85 ± 10 cycle/min 27W × 2 pcs + 3.4W
Sidestand Relay: Model/Manufacturer Coil Winding Resistance Diode	4U8-01/OMRON 75Ω ± 10% at 20°C (68°F) No
Safety Relay (Relay Assembly): Model/Manufacturer Diode	FX257N/NIPPON DENSO No
Oil Level Switch: Model/Manufacturer	4U8-00/HIPPON DENSO
Circuit Breaker: Type Amperage for Individual Circuit × Quantity: MAIN HEADLIGHT SIGNAL IGNITION RESERVE	Fuse 20A × 1 pcs. 10A × 1 pcs. 10A × 1 pcs. 10A × 1 pcs. 20A × 1 pcs, 10A × 1 pcs.

GENERAL TORQUE SPECIFICATIONS

This chart specifies torque for standard fasteners with standard I.S.O. pitch threads. Torque specifications for special components or assemblies are included in the applicable sections of this book. To avoid warpage, tighten multi-fastener assemblies in a crisscross fashion, in progressive stages, until full torque is reached. Unless otherwise specified, torque specifications call for clean, dry threads. Components should be at room temperature.

A (Nut)	B (Bolt)	General torque specifications		
		Nm	m·kg	ft·lb
10 mm	6 mm	6	0.6	4.3
12 mm	8 mm	15	1.5	11
14 mm	10 mm	30	3.0	22
17 mm	12 mm	55	5.5	40
19 mm	14 mm	85	8.5	61
22 mm	16 mm	130	13.0	94

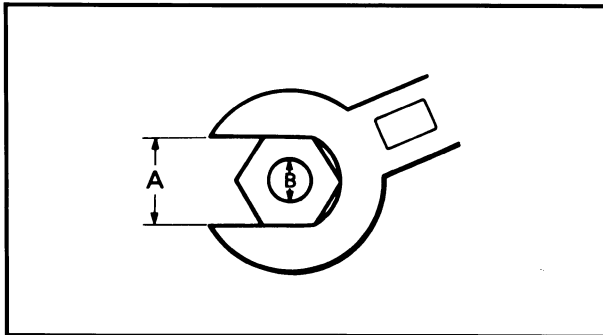

A: Distance across flats
B: Outside thread diameter



DEFINITION OF UNITS

Unit	Read	Definition	Measure
mm	millimeter	10^{-3} meter	Length
cm	centimeter	10^{-2} meter	Length
kg	kilogram	10^3 gram	Weight
N	Newton	$1 \text{ kg} \times \text{m}/\text{sec}^2$	Force
Nm	Newton meter	$\text{N} \times \text{m}$	Torque
m•kg	Meter kilogram	$\text{m} \times \text{kg}$	Torque
Pa	Pascal	N/m^2	Pressure
N/mm	Newton per millimeter	N/mm	Spring rate
L	Liter		Volume or Capacity
cm ³	Cubic centimeter		Volume or Capacity
r/min	Rotation per minute		Engine Speed

CONVERSION TABLES

Metric to inch system		
Known	Multiplier	Result
m•kg	7.233	ft•lb
m•kg	86.80	in•lb
cm•kg	0.0723	ft•lb
cm•kg	0.8680	in•lb
kg	2.205	lb
g	0.03527	oz
km/lit	2.352	mpg
km/hr	0.6214	mph
km	0.6214	mi
m	3.281	ft
m	1.094	yd
cm	0.3937	in
mm	0.03937	in
cc (cm ³)	0.03382	oz (US liq)
cc (cm ³)	0.06102	cu in
lit (liter)	2.1134	pt (US liq)
lit (liter)	1.057	qt (US liq)
lit (liter)	0.2642	gal (US liq)
kg/mm	56.007	lb/in
kg/cm	14.2234	psi (lb/in)
Centigrade (°C)	$9/5 (°\text{C}) + 32$	Fahrenheit (°F)

Inch to metric system		
Known	Multiplier	Result
ft•lb	0.13826	m•kg
in•lb	0.01152	m•kg
ft•lb	13.831	cm•kg
in•lb	1.1521	cm•kg
lb	0.4535	kg
oz	28.352	g
mpg	0.4252	km/lit
mph	1.609	km/hr
mi	1.609	km
ft	0.3048	m
yd	0.9141	m
in	2.54	cm
in	25.4	mm
oz (US liq)	29.57	cc (cm ³)
cu in	16.387	cc (cm ³)
pt (US liq)	0.4732	lit (liter)
qt (US liq)	0.9461	lit (liter)
gal (US liq)	3.785	lit (liter)
lb/in	0.017855	kg/mm
psi (lb/in)	0.07031	kg/cm
Fahrenheit (°C)	$5/9 (F^{\circ}-32)$	Centigrade (°F)



LUBRICATION DIAGRAM

① Crankshaft

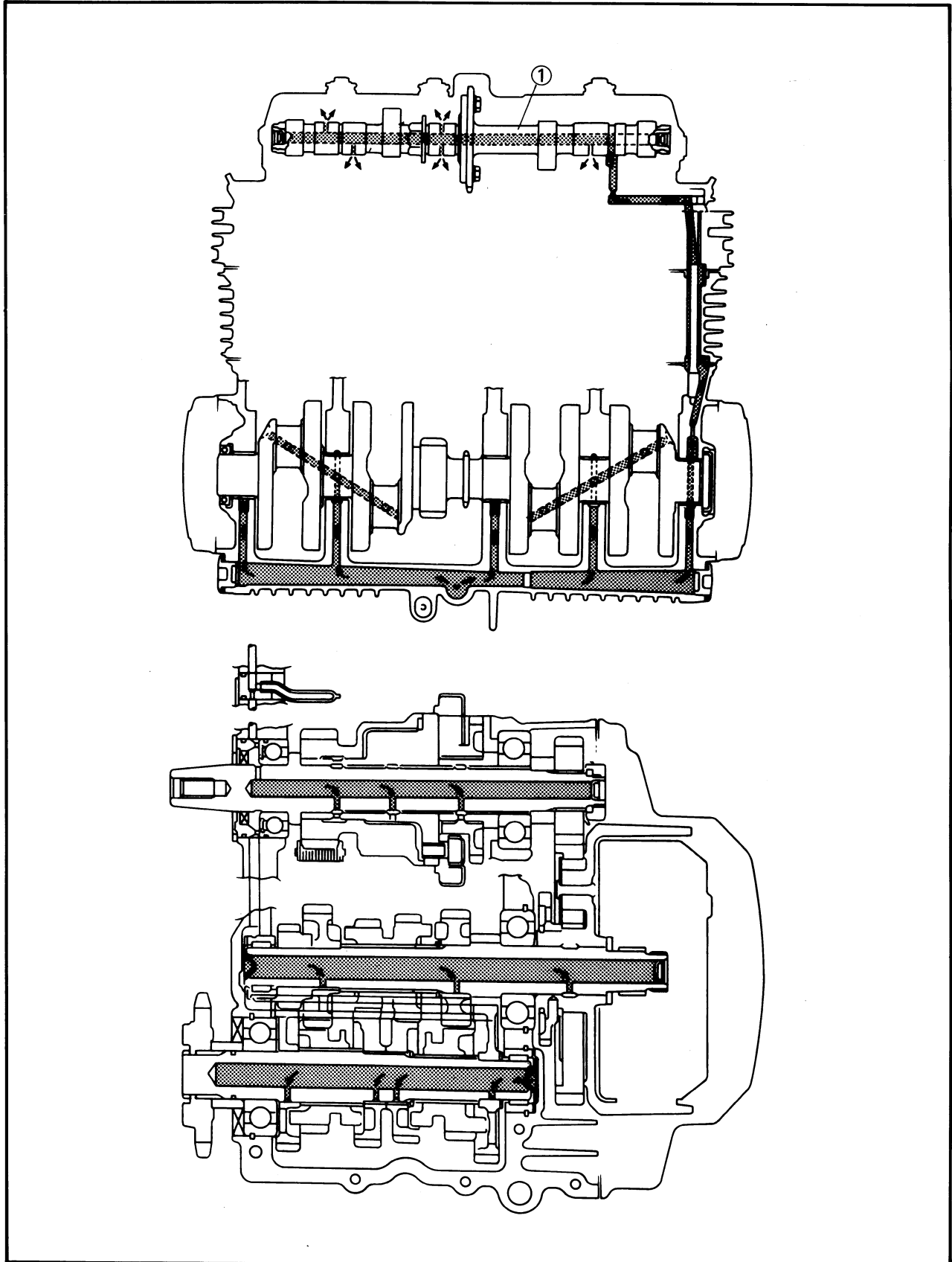



- ① Generator shaft
- ② Main axle
- ③ Drive axle
- ④ Crankshaft
- ⑤ Oil filter

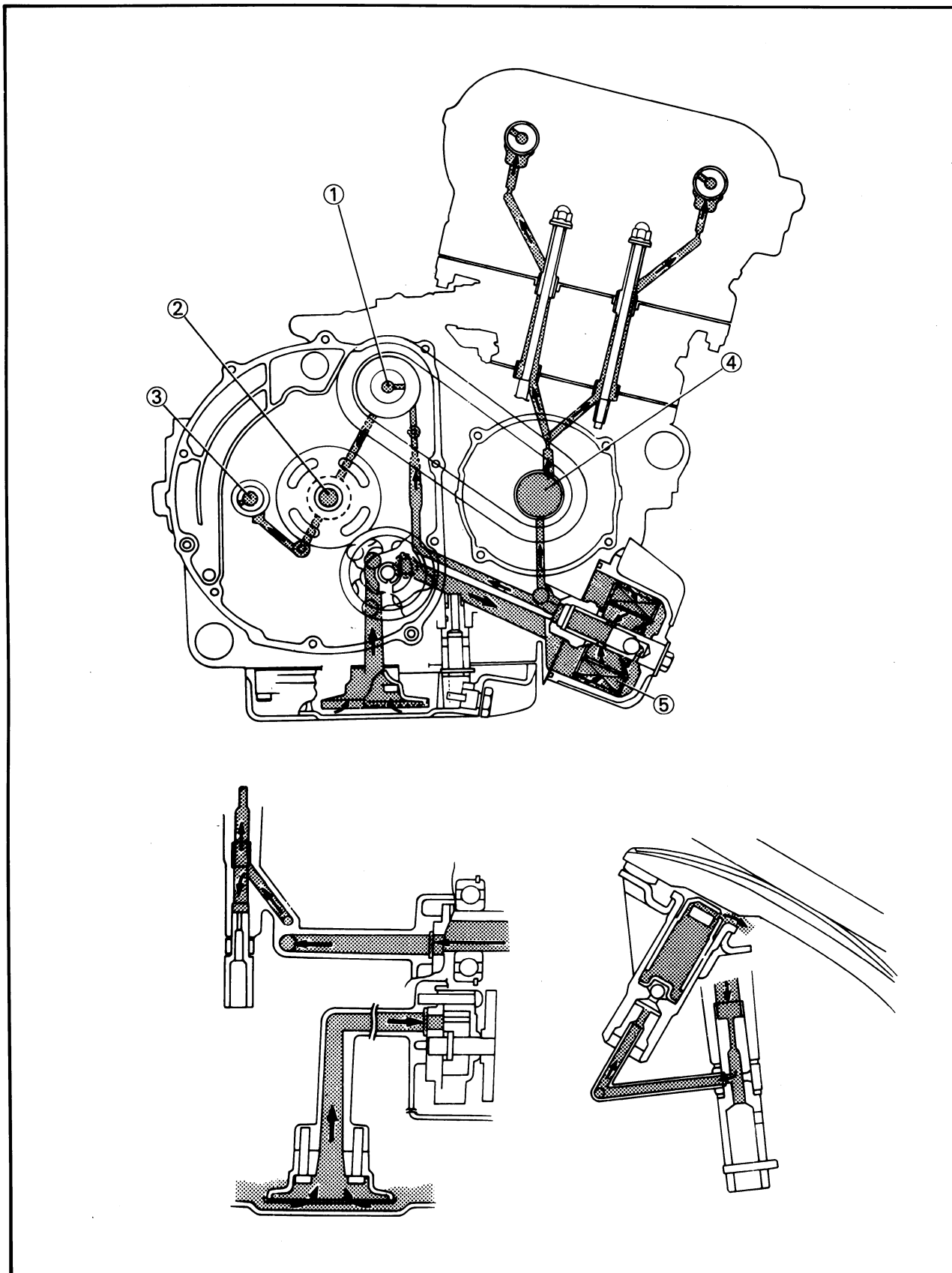



CABLE ROUTING

- ① Starter cable
 - ② Handlebar switch lead (Left)
 - ③ Clutch cable
 - ④ Brake hose
 - ⑤ Throttle cable
 - ⑥ Handlebar switch lead (Right)
 - ⑦ Band
 - ⑧ Main switch lead
 - ⑨ Outer cover
 - ⑩ Tachometer lead
 - ⑪ Flasher light lead (Right)
 - ⑫ Flasher light lead (Left)
 - ⑬ Speedometer light lead
 - ⑭ Indicator light lead
- A Speedometer cable:
Pass the speedometer cable outside the outer cover.
 - B Clutch cable:
Pass the clutch cable behind the outer cover stay.
 - C Connect the couplers inside the outer cover.

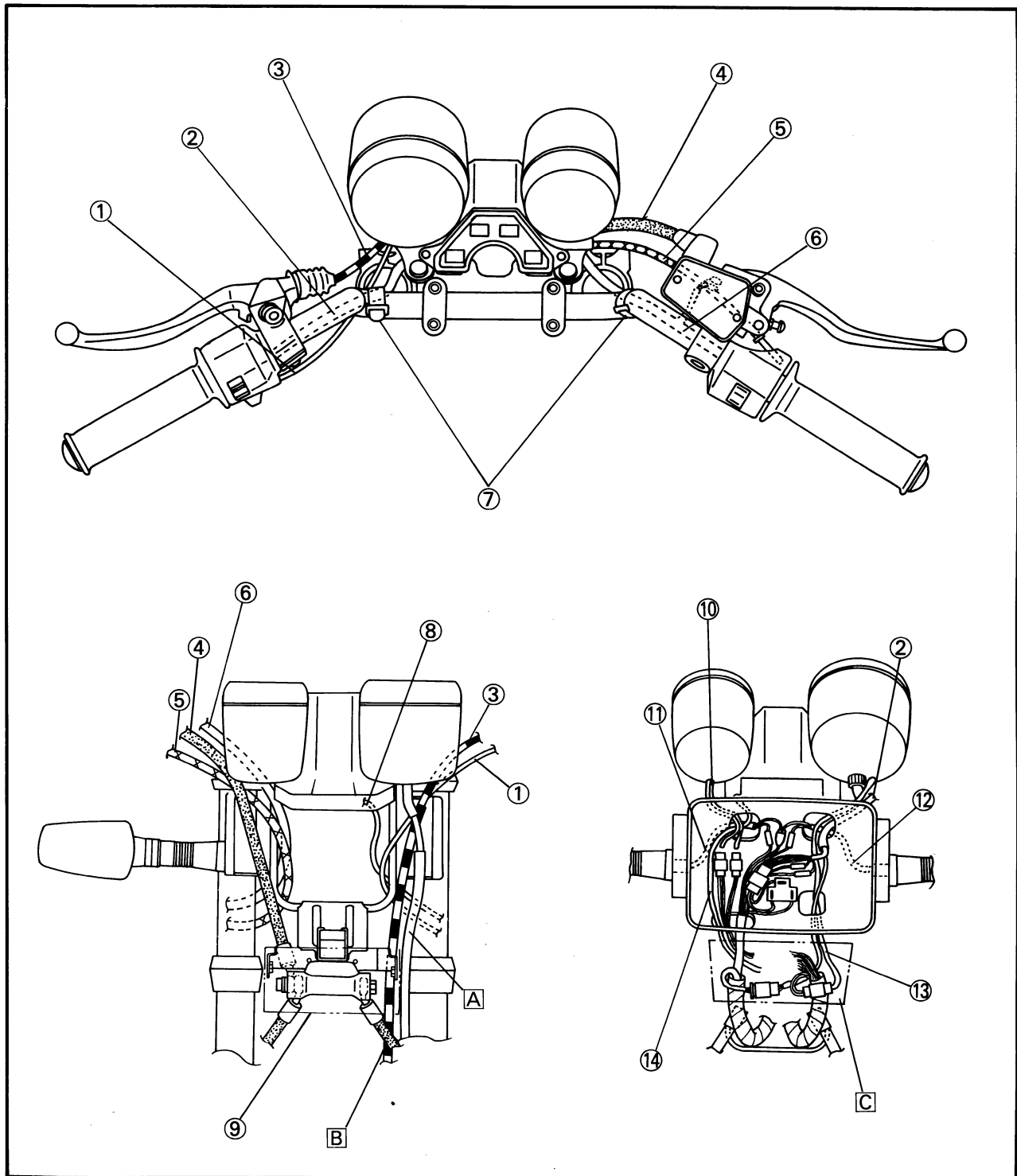



CABLE ROUTING

- ① Band
- ② Sidestand relay
- ③ Brake hose
- ④ Clutch cable
- ⑤ Relay assembly
- ⑥ Starter motor
- ⑦ Pickup coil
- ⑧ A.C. generator
- ⑨ Sidestand switch
- ⑩ Clamp
- ⑪ Rear flasher light lead
- ⑫ License light lead
- ⑬ Ignition coil (Right)
- ⑭ Ignition coil (Left)

- ⑮ "4" mark → #4 cylinder
- ⑯ "3" mark → #3 cylinder
- ⑰ "2" mark → #2 cylinder
- ⑱ "1" mark → #1 cylinder

- A Pass the starter cable between the locating damper and ignition coil.
- B After connecting the couplers, locate them above the ignition coil.
- C Pass the horn lead between the ignition coils.

- D Guide:
Clamp the wire harness.
- E Cable holder:
Pass the speedometer cable through the cable holder.
- F Pass the ignition coil leads through the coil stay.

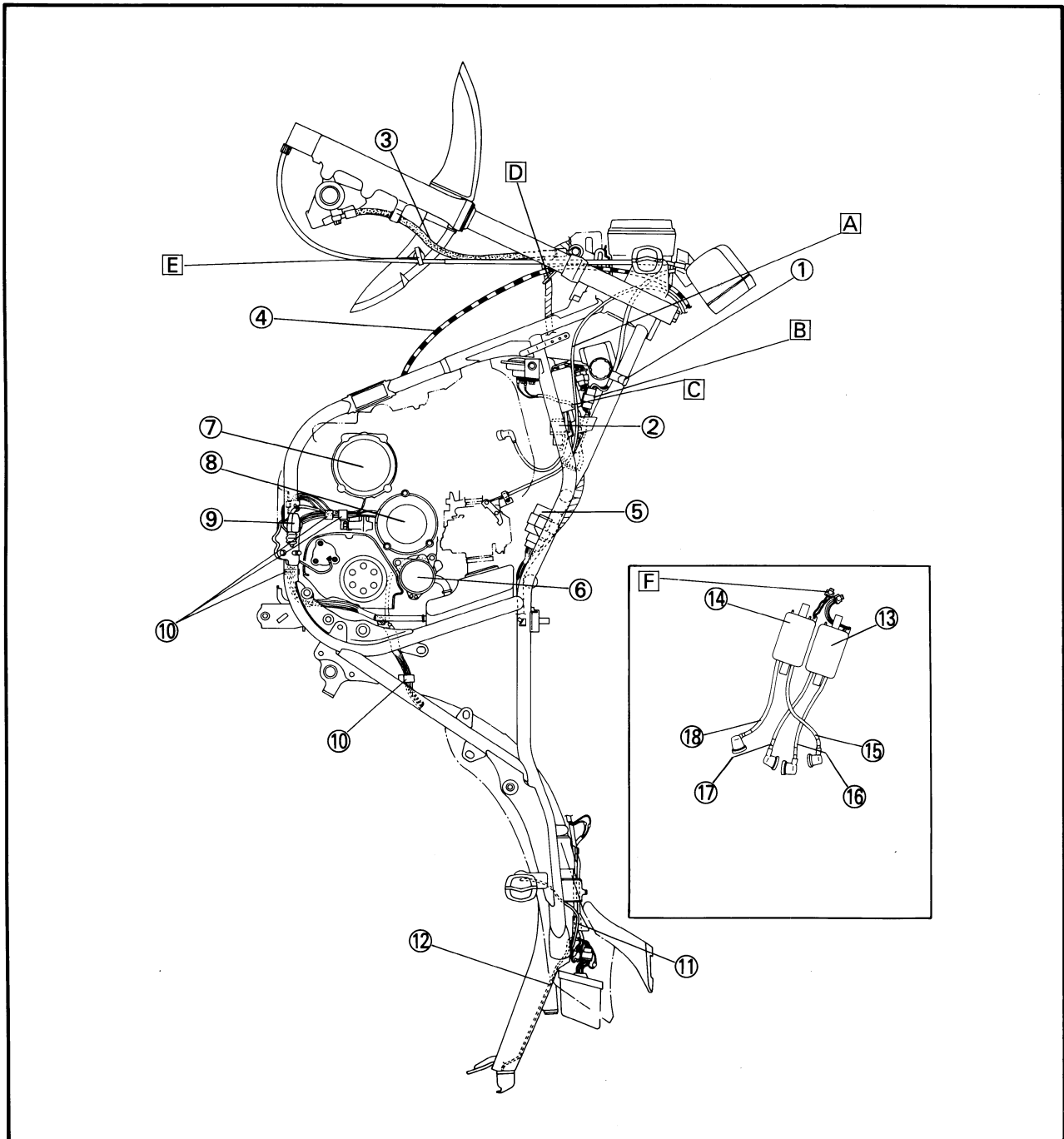



- ① Band
- ② Cross pipe
- ③ Relay assembly
- ④ Ignitor unit
- ⑤ Fuse box
- ⑥ To pickup coil
- ⑦ To starter relay
- ⑧ Diode
- ⑨ Clamp
- ⑩ Rear flasher light lead (Right)
- ⑪ License light lead
- ⑫ Taillight lead
- ⑬ Rear flasher light lead (Left)

- A White tape:
Align the white tape with the cross pipe as shown.
- B Pass the wire harness between air cleaner box and battery box.
- C Pass the flasher light lead between the frame and rear fender.
- D Locate the couplers and leads inside the rear fender.

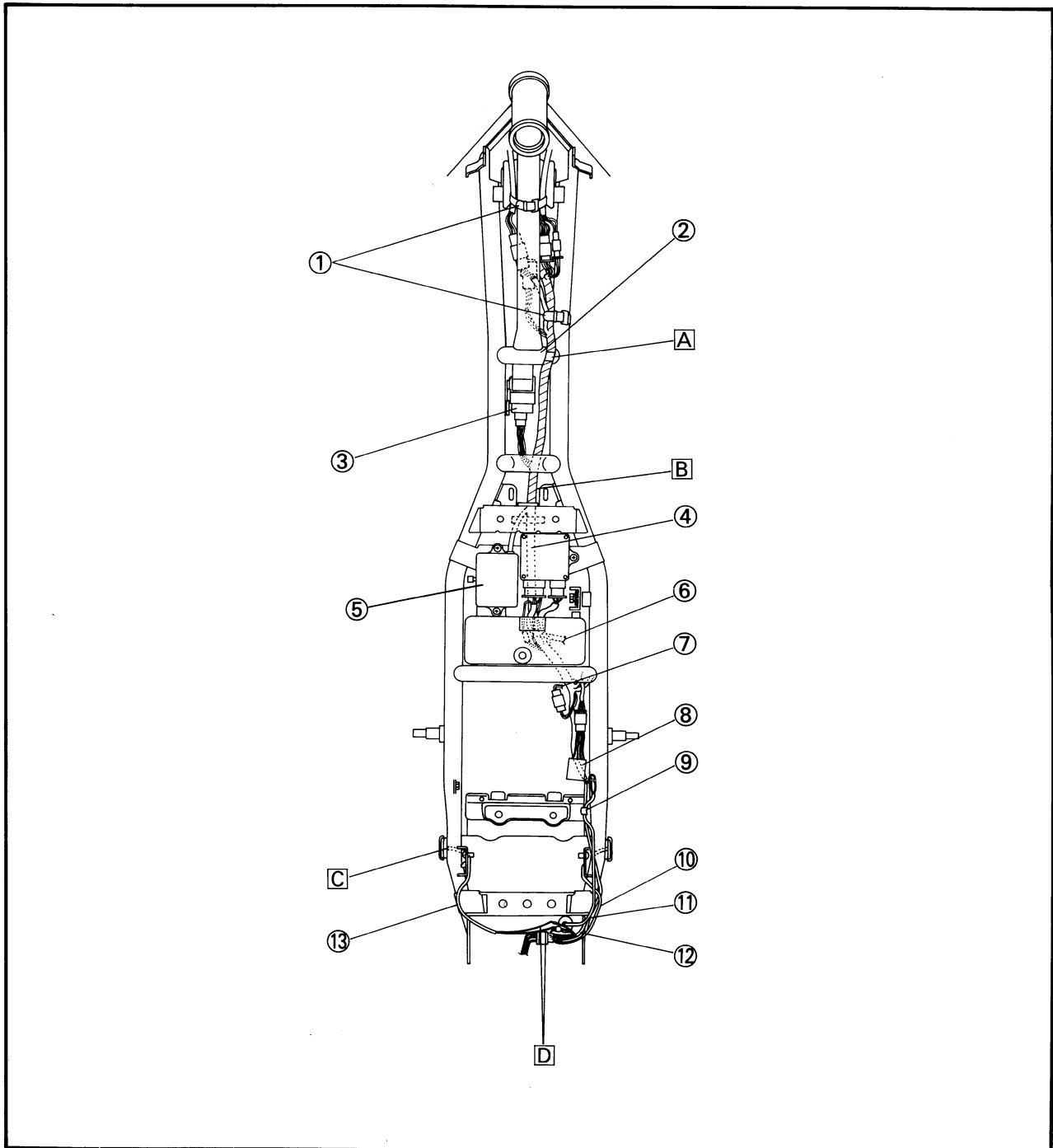



CABLE ROUTING

- ① To wire harness
- ② Starter relay
- ③ Rectifier-regulator
- ④ Wire harness
- ⑤ Handlebar switch lead (Right)
- ⑥ Battery breather pipe
- ⑦ Earth lead
- ⑧ Rear brake switch
- ⑨ Clamp
- ⑩ To A.C. generator
- ⑪ Starter relay lead
- ⑫ Oil level switch lead
- ⑬ Sidestand switch lead

- A After connecting the couplers, locate the couplers behind the battery box.
- B Clamp the earth lead with the ignition coil securing screw.
- C Pass the throttle cable under the locating damper.
- D Pass the clutch cable through the guide and between EX. pipe #2 and #3.

- E Pass the battery negative (-) lead inside the battery box.
- F Clamp the earth lead with the battery cover securing bolt.

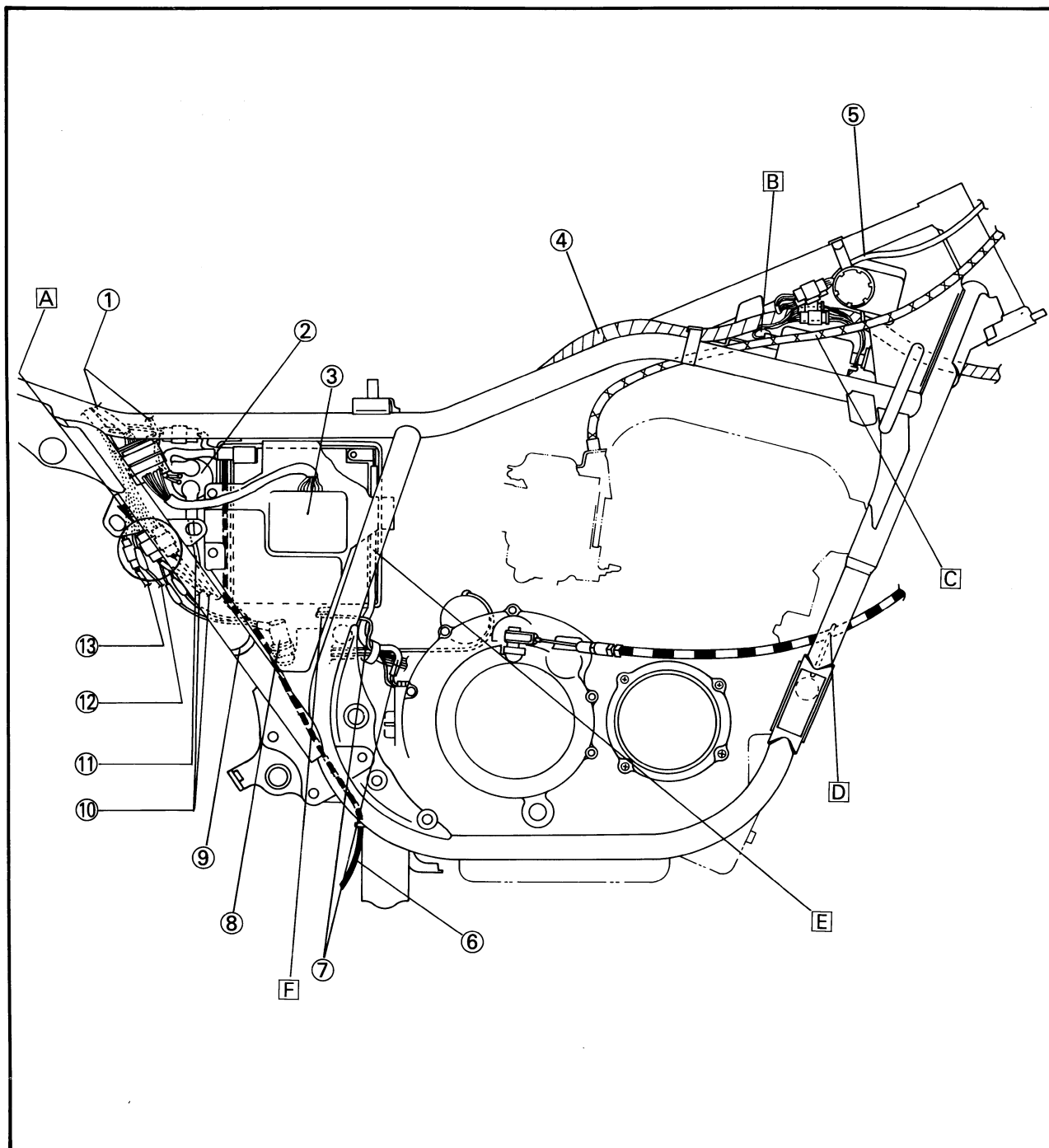



- ① To fuel tank
- ② Fuel tank breather pipe
- ③ Battery breather pipe
- ④ Rear arm
- A Pass the battery breather pipe through the guide hole on the stop switch bracket.

- B Pass the fuel tank and battery breather pipe between the rear arm cross tube and rear arm pivot.
- C Pass the breather pipes through the guide.

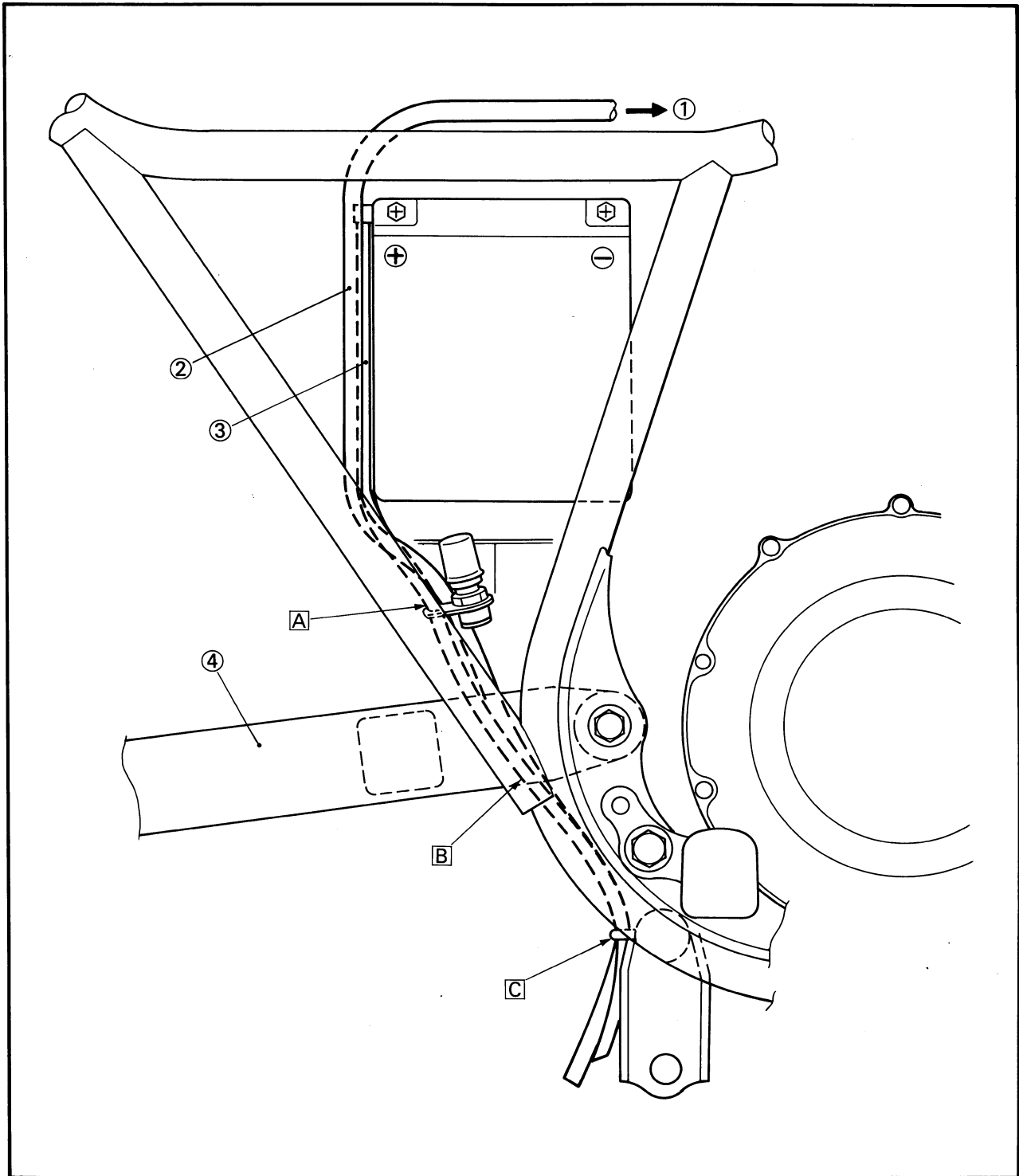



CALIFORNIA ONLY

- | | |
|--------------------------|-------------|
| ① Ignition coil | ⑧ Clamp |
| ② Roll over valve | ⑨ Crankcase |
| ③ Air vent control valve | ⑩ Frame |
| ④ #3 Carburetor | |
| ⑤ #2 Carburetor | |
| ⑥ From fuel tank | |
| ⑦ To canister | |

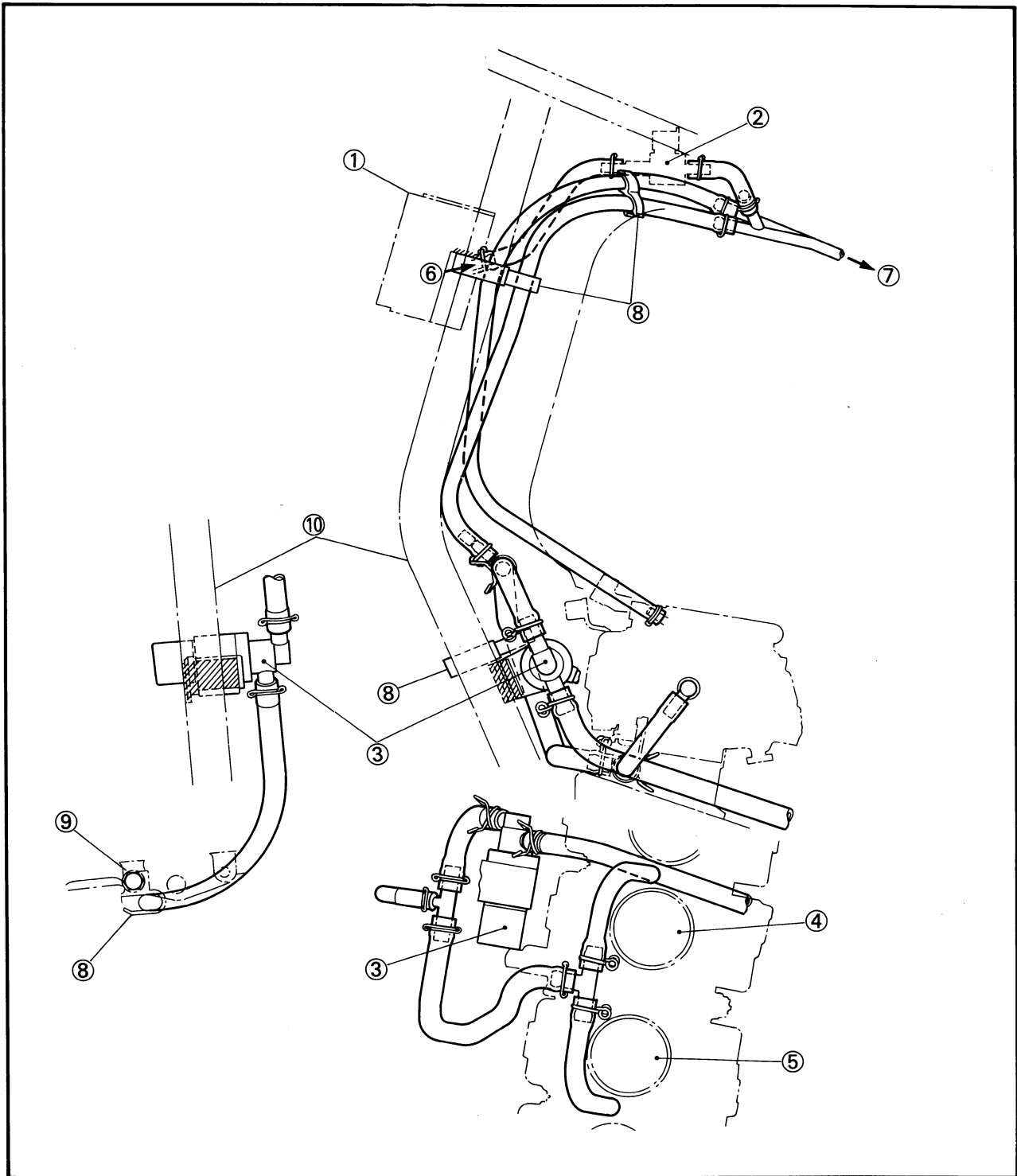

YX600S/YX600SC WIRING DIAGRAM

- ① Front flasher light (L)
- ② Clutch switch
- ③ "TURN" switch
- ④ "HORN" switch
- ⑤ "LIGHTS" (dimmer) switch
- ⑥ Headlight
- ⑦ "HIGH BEAM" indicator light
- ⑧ "NEUTRAL" indicator light
- ⑨ "OIL" indicator light
- ⑩ "TURN" indicator light
- ⑪ Reed switch
- ⑫ Meter light
- ⑬ Tachometer
- ⑭ Horn
- ⑮ Main switch
- ⑯ Front brake switch
- ⑰ "START" switch
- ⑱ "ENGINE STOP" switch
- ⑲ Front flasher light (R)
- ⑳ Sidestand switch
- ㉑ Sidestand relay
- ㉒ Relay assembly
- ㉓ Ignitor unit
- ㉔ Rear brake switch
- ㉕ Starter motor
- ㉖ Starter relay
- ㉗ Battery
- ㉘ Fuse
- ㉙ License light
- ㉚ Rear flasher light (R)
- ㉛ Tail/Brake light
- ㉜ Rear flasher light (L)
- ㉝ Air vent control valve (For YX600SC only)
- ㉞ Diode
- ㉟ Rectifier/regulator
- ㊱ Neutral switch
- ㊲ Oil level switch
- ㊳ AC magneto
- ㊴ Body earth
- ㊵ Pickup coil
- ㊶ Spark plug
- ㊷ Ignition coil

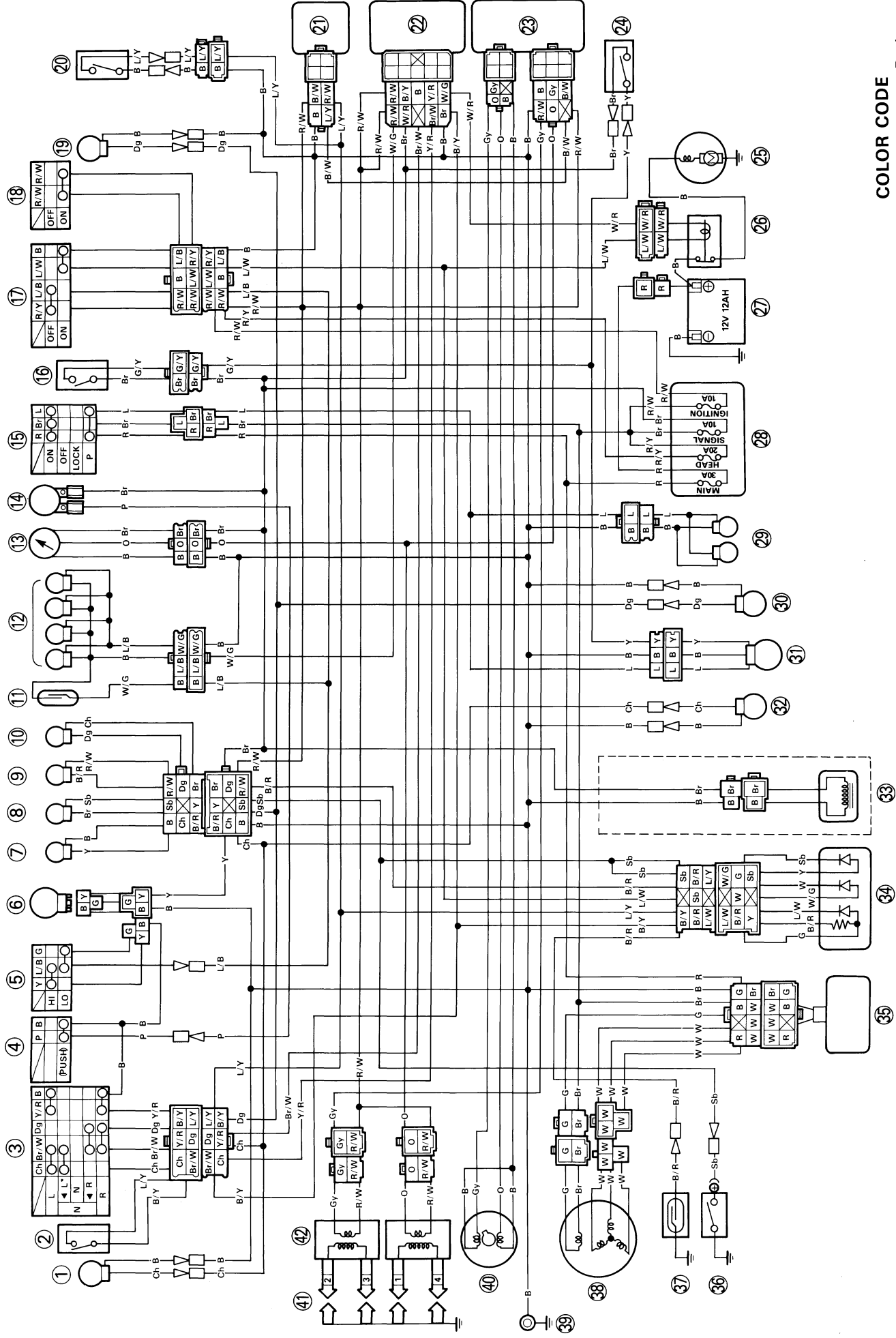

COLOR CODE

R	Red
B	Black
W	White
Y	Yellow
G	Green
L	Blue
Br	Brown
Ch	Chocolate
Dg	Dark green
P	Pink
O	Orange
Sb	Sky blue
Gy	Gray

R/W	Red/White
R/Y	Red/Yellow
B/W	Black/White
B/Y	Black/Yellow
B/R	Black/Red
W/R	White/Red
W/G	White/Green
Y/R	Yellow/Red
G/Y	Green/Yellow
L/W	Blue/White
L/Y	Blue/Yellow
L/B	Blue/Black
Br/W	Brown/White

FOREWORD

This Supplementary Service Manual has been prepared to introduce new service and new data for the YX600U/UC. For complete information on service procedures, it is necessary to use this Supplementary Service Manual together with following manual:

YX600S/SC Service Manual: LIT-11616-05-06

**YX600U/YX600UC
SUPPLEMENTARY SERVICE MANUAL
©1987 by Yamaha Motor Corporation, U.S.A.
1st Edition, July 1987
All rights reserved. Any reprinting or
unauthorized use without the written
permission of Yamaha Motor Corporation,
U.S.A. is expressly prohibited.
Printed in U.S.A.
P/N LIT-11616-06-16**

NOTICE

This manual was written by the Yamaha Motor Company primarily for use by Yamaha dealers and their qualified mechanics. It is not possible to put an entire mechanic's education into one manual, so it is assumed that persons using this book to perform maintenance and repairs on Yamaha motorcycles have a basic understanding of the mechanical concepts and procedures inherent in motorcycle repair technology. Without such knowledge, attempted repairs or service to this model may render it unfit to use and/or unsafe.

Yamaha Motor Company, Ltd. is continually striving to improve all models manufactured by Yamaha. Modifications and significant changes in specifications or procedures will be forwarded to all Authorized Yamaha dealers and will, where applicable, appear in future editions of this manual.

TECHNICAL PUBLICATIONS
SERVICE DIVISION
MOTORCYCLE GROUP
YAMAHA MOTOR CO., LTD.

HOW TO USE THIS MANUAL

PARTICULARLY IMPORTANT INFORMATION

This material is distinguished by the following notation.

NOTE: A **NOTE** provides key information to make procedures easier or clearer.

CAUTION:

A **CAUTION** indicates special procedures that must be followed to avoid damage to the motorcycle.

WARNING:

A **WARNING** indicates special procedures that must be followed to avoid injury to a motorcycle operator or person inspecting or repairing the motorcycle.

MANUAL FORMAT



















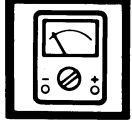

All of the procedures in this manual are organized in a sequential, step-by-step format. The information has been compiled to provide the mechanic with an easy to read, handy reference that contains comprehensive explanations of all disassembly, repair, assembly, and inspection operations.

In this revised format, the condition of a faulty component will precede an arrow symbol and the course of action required will follow the symbol, e.g.,

- Bearings
Pitting/Damage → Replace.

EXPLODED DIAGRAM

Each chapter provides exploded diagrams before each disassembly section for ease in identifying correct disassembly and assembly procedures.

① GEN INFO 	② INSP ADJ 	
③ ENG 	④ COOL 	
⑤ CARB 	⑥ CHAS 	
⑦ ELEC 	⑧ APPX 	
⑨ 	⑩ 	
⑪ 	⑫ 	
⑬ 	⑭ 	
⑮ 	⑯ 	⑰ 
⑱ 	⑲ 	⑳ 
㉑ 		

ILLUSTRATED SYMBOLS (Refer to the illustration)

Illustrated symbols ① to ⑧ are designed as thumb tabs to indicate the chapter's number and content.

- ① General information
- ② Periodic inspection and adjustment
- ③ Engine
- ④ Cooling system
- ⑤ Carburetion
- ⑥ Chassis
- ⑦ Electrical
- ⑧ Appendices

Illustrated symbols ⑨ to ⑭ are used to identify the specifications appearing.

- ⑨ Filling fluid
- ⑩ Lubricant
- ⑪ Tightening
- ⑫ Wear limit, clearance
- ⑬ Engine speed
- ⑭ Ω , V, A

Illustrated symbols ⑮ to ㉑ in the exploded diagram indicate grade of lubricant and location of lubrication point.

- ⑮ Apply engine oil
- ⑯ Apply gear oil
- ⑰ Apply molybdenum disulfide oil
- ⑱ Apply wheel bearing grease
- ⑲ Apply lightweight lithium-soap base grease
- ⑳ Apply molybdenum disulfide grease
- ㉑ Apply locking agent (LOCTITE®)

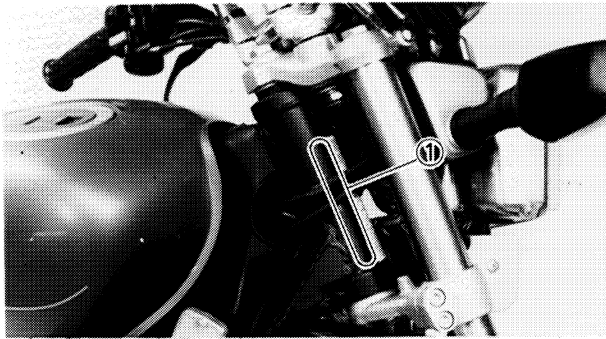

GENERAL INFORMATION

MOTORCYCLE IDENTIFICATION VEHICLE IDENTIFICATION NUMBER

The vehicle identification number ① is stamped into the right side of the steering head pipe.

Starting Serial Number:
YX600U (Except for California)
JYA1UJE0*JA000101
YX600UC (For California)
JYA1ULC0*JA000101

NOTE: _____

The vehicle identification number is used to identify your motorcycle and may be used to register your motorcycle with the licensing authority in your state.

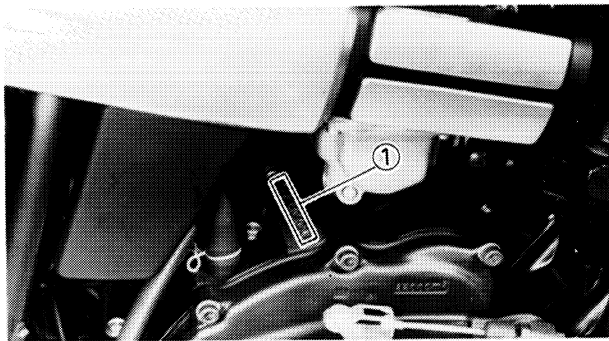

ENGINE SERIAL NUMBER

The engine serial number ① is stamped into the elevated part of the left rear section of the engine.

Starting Serial Number:
YX600U (Except for California)
1UJ-047101
YX600UC (For California)
1UL-00701

NOTE: _____

- The first three digits of these numbers are for model identifications; the remaining digits are the unit production number.
- Designs and specifications are subject to change without notice.



APPENDICES

SPECIFICATIONS

GENERAL SPECIFICATIONS

Model	YX600U/YX600UC
Model Code Number:	2WY (For YX600U) 2XA (For YX600UC)
Vehicle Identification Number:	JYA1UJE0*JA000101 (For YX600U) JYA1ULC0*JA000101 (For YX600UC)
Engine Starting Number:	1UJ-047101 (For YX600U) 1UL-00701 (For YX600UC)
Bulb Wattage (Quantity):	
Headlight	60W/55W (1 pcs.)
Tail/Brake Light	8W/27W (1 pcs.)
Flasher Light (Front)/Front Position Light	27W/8W (2 pcs.)
Flasher Light (Rear)	27W (2 pcs.)
License Light	3.8W (2 pcs.)
Meter Light	3.4W (4 pcs.)

YX600U/YX600UC WIRING DIAGRAM

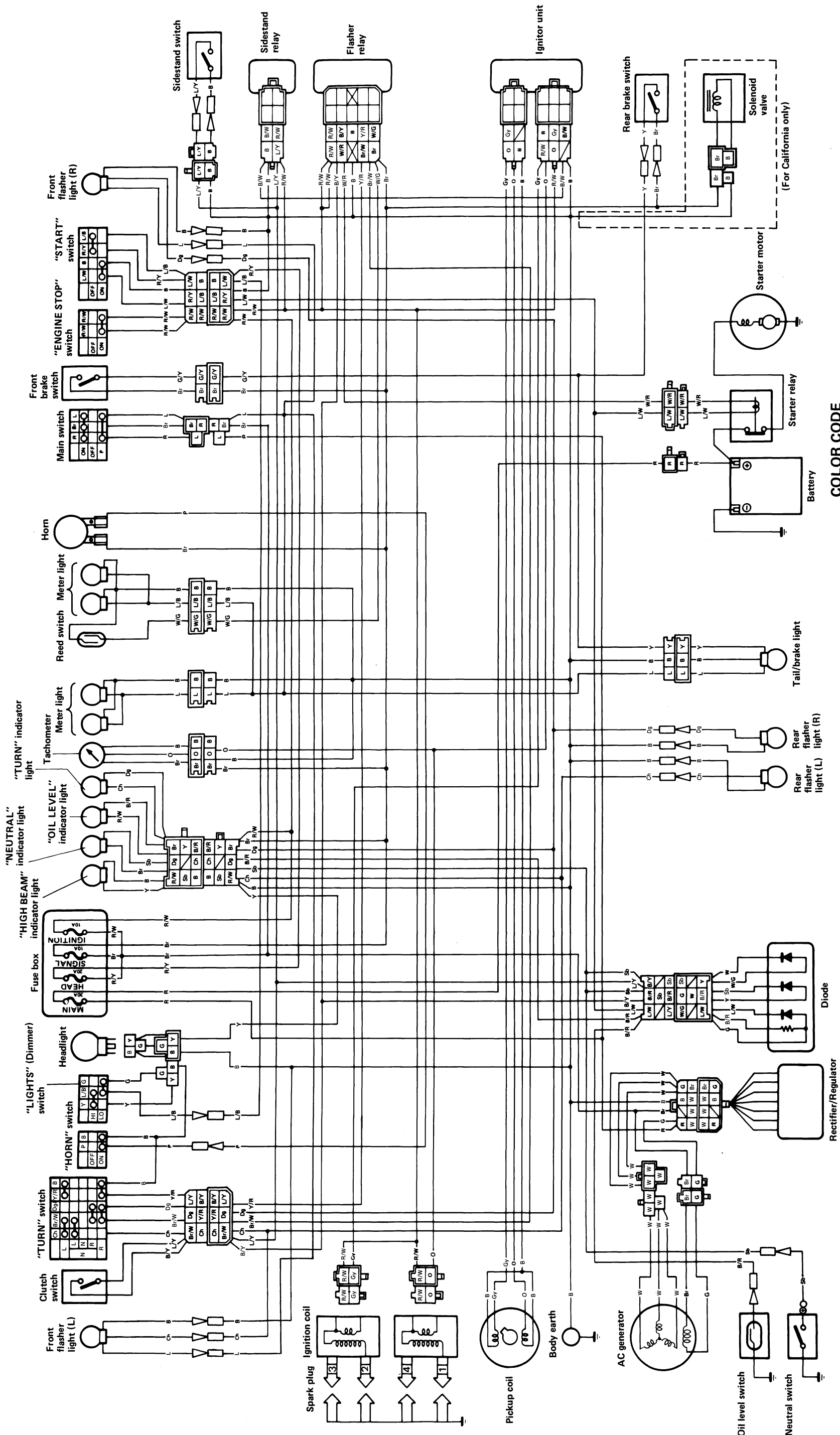

COLOR CODE

B	Black
Ch	Chocolate
L	Blue
Dg	Dark green
Y	Yellow
Sb	Sky blue
O	Orange
P	Pink
W	White
G	Green
R	Red
L/Y	Blue/Yellow
L/B	Blue/Black
L/W	Blue/White
Y/R	Yellow/Red
R/Y	Red/Yellow
R/W	Red/White
R/B	Red/Black
W/G	White/Green

FOREWORD

This Supplementary Service Manual has been prepared to introduce new service and new data for the YX600W/WC. For complete information on service procedures, it is necessary to use this Supplementary Service Manual together with following manual:

YX600S/SC Service Manual: LIT-11616-05-06
YX600V/VC Supplementary Service Manual: LIT-11616-06-16

YX600W/YX600WC
SUPPLEMENTARY SERVICE MANUAL
© 1989 by Yamaha Motor Corporation, U.S.A.
1st Edition, January 1989
All rights reserved. Any reprinting or
unauthorized use without the written
permission of Yamaha Motor Corporation,
U.S.A. is expressly prohibited.
Printed in U.S.A.
P/N LIT-11616-06-88

NOTICE

This manual was written by the Yamaha Motor Company primarily for use by Yamaha dealers and their qualified mechanics. It is not possible to put an entire mechanic's education into one manual, so it is assumed that persons using this book to perform maintenance and repairs on Yamaha motorcycles have a basic understanding of the mechanical concepts and procedures inherent in motorcycle repair technology. Without such knowledge, attempted repairs or service to this model may render it unfit to use and/or unsafe.

Yamaha Motor Company, Ltd. is continually striving to improve all models manufactured by Yamaha. Modifications and significant changes in specifications or procedures will be forwarded to all Authorized Yamaha dealers and will, where applicable, appear in future editions of this manual.

TECHNICAL PUBLICATIONS
SERVICE DIVISION
MOTORCYCLE OPERATIONS
YAMAHA MOTOR CO., LTD.

HOW TO USE THIS MANUAL

PARTICULARLY IMPORTANT INFORMATION

This material is distinguished by the following notation.

NOTE: A NOTE provides key information to make procedures easier or clearer.

CAUTION: A CAUTION indicates special procedures that must be followed to avoid damage to the motorcycle.

WARNING: A WARNING indicates special procedures that must be followed to avoid injury to a motorcycle operator or person inspecting or repairing the motorcycle.

MANUAL FORMAT



















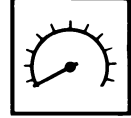
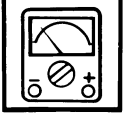

All of the procedures in this manual are organized in a sequential, step-by-step format. The information has been compiled to provide the mechanic with an easy to read, handy reference that contains comprehensive explanations of all disassembly, repair, assembly, and inspection operations.

In this revised format, the condition of a faulty component will precede an arrow symbol and the course of action required will follow the symbol, e.g.,

- Bearings
Pitting/Damage → Replace.

EXPLODED DIAGRAM

Each chapter provides exploded diagrams before each disassembly section for ease in identifying correct disassembly and assembly procedures.

① GEN INFO 	② INSP ADJ 	
③ ENG 	④ COOL 	
⑤ CARB 	⑥ CHAS 	
⑦ ELEC 	⑧ APPX 	
⑨ 	⑩ 	
⑪ 	⑫ 	
⑬ 	⑭ 	
⑮ 	⑯ 	⑰ 
⑱ 	⑲ 	⑳ 
㉑ 		

ILLUSTRATED SYMBOLS (Refer to the illustration)

Illustrated symbols ① to ⑧ are designed as thumb tabs to indicate the chapter's number and content.

- ① General information
- ② Periodic inspection and adjustment
- ③ Engine
- ④ Cooling system
- ⑤ Carburetion
- ⑥ Chassis
- ⑦ Electrical
- ⑧ Appendices

Illustrated symbols ⑨ to ⑭ are used to identify the specifications appearing in the text.

- ⑨ Filling fluid
- ⑩ Lubricant
- ⑪ Tightening
- ⑫ Wear limit, clearance
- ⑬ Engine speed
- ⑭ Ω , V, A

Illustrated symbols ⑮ to ㉑ in the exploded diagram indicate grade of lubricant and location of lubrication point.

- ⑮ Apply engine oil
- ⑯ Apply gear oil
- ⑰ Apply molybdenum disulfide oil
- ⑱ Apply wheel bearing grease
- ⑲ Apply lightweight lithium-soap base grease
- ⑳ Apply molybdenum disulfide grease
- ㉑ Apply locking agent (LOCTITE®)

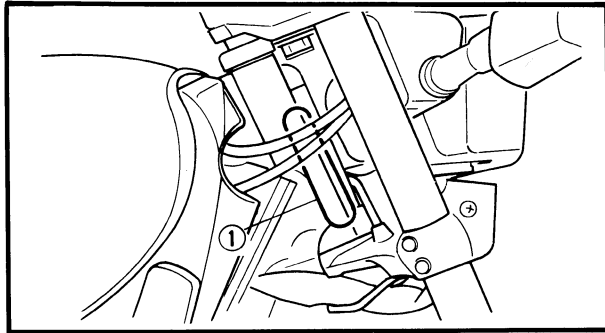

**GENERAL
INFORMATION**

**MOTORCYCLE IDENTIFICATION
VEHICLE IDENTIFICATION NUMBER**

The vehicle identification number ① is stamped into the right side of the steering head pipe.

Starting Serial Number:
 YX600W (Except for California)
 JYA3LTE0 * KA000101
 YX600WC (For California)
 JYA3LTC0 * KA007101

NOTE: _____
 The vehicle identification number is used to identify your motorcycle and may be used to register your motorcycle with the licensing authority in your state.

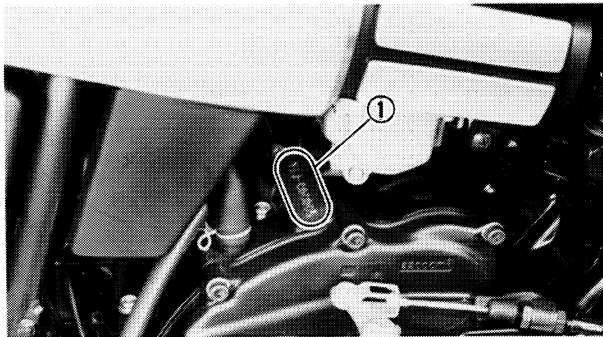

ENGINE SERIAL NUMBER

The engine serial number ① is stamped into the elevated part of the left rear section of the engine.

Starting Serial Number:
 YX600W (Except for California)
 3LT-000101
 YX600WC (For California)
 3LT-007101

NOTE: _____

- The first three digits of these numbers are for model identifications; the remaining digits are the unit production number.
- Designs and specifications are subject to change without notice.

APPENDICES

SPECIFICATIONS

GENERAL SPECIFICATIONS

Model	YX600W/YX600WC
Model Code Number:	3LT1 (For YX600W) 3LT2 (For YX600WC)
Vehicle Identification Number:	JYA3LTE0 * KA000101 (For YX600W) JYA3LTC0 * KA007101 (For YX600WC)
Engine Starting Number:	3LT-000101 (For YX600W) 3LT-007101 (For YX600WC)

Chassis

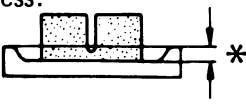
Model	YX600W/YX600WC
Front Disc Brake: Type Outside Dia. x Thickness Pad Thickness: 	Dual disc 267 x 5 mm (10.5 x 0.2 in) 5.5 mm (0.21 in) < Limit > * 0.5 mm (0.019 in) 5.5 mm (0.21 in) < Limit > * 0.5 mm (0.019 in)
Master Cylinder Inside Dia. Caliper Cylinder Inside Dia. Brake Fluid Type	15.87 mm (0.62 in) 42.8 mm (1.50 in) DOT #3 or DOT #4
Clutch Lever Free Play (At Lever Pivot Point)	2 ~ 3 mm (0.08 ~ 0.10 in)

Electrical

Model	YX600W/YX600WC
T.C.I.: Pickup Coil Resistance (Color) T.C.I. Unit – Manufacturer	81 ~ 121Ω at 20°C (68°F) (White – Red) (White – Black) TID14-79 HITACHI
Ignition Coil Model/Manufacturer Minimum Spark Gap Primary Winding Resistance Secondary Winding Resistance Spark Plug Cap Resistance	CM12-40/HITACHI 6 mm (0.24 in) or more at 500 r/min 1.8 ~ 2.2Ω at 20°C (68°F) 9.6 ~ 14.4 kΩ at 20°C (68°F) 10 kΩ



Electrical

Model	YX600W/YX600WC
A.C. Generator: Model/Manufacturer Nominal Output Starter Coil Resistance	FL118-16/HITACHI 12V, 21A at 5,000 r/min 0.31 ~ 0.37Ω at 20°C (68°F) (White – White)
Voltage Regulator: Type Model/Manufacturer No Load Regulated Voltage	Field control SH538A-12/SHINDENGEN 14 ~ 15V
Rectifier: Model/Manufacturer Capacity Withstand Voltage	SH538A-12/SHINDENGEN 25A 240V
Electrical Starter System: Type Starter Motor: Model/Manufacturer Output Armature Coil Resistance Brush – Overall Length < Limit > – Spring Force Commutator Dia. Wear Limit Mica Undercut Starter Relay: Model/Manufacturer Amperage Rating Coil Resistance	Constant mesh type SM-13 MITSUBA 0.5 kw 0.012Ω ± 10% at 20°C (68°F) 12.5 mm (0.50 in) 4 mm (0.16 in) 340 ~ 460 g (12.0 ~ 16.2 oz) 28 mm (1.10 in) 27 mm (1.06 in) 0.8 mm (0.03 in) 3AY/HITACHI 100A 4.3Ω at 20°C (68°F)
Flasher Relay (Relay Assembly): Type Model/Manufacturer Self Cancelling Device Flasher Frequency Wattage	Semi transistor type FB257H/NIPPON DENSO Yes 85 ± 10 cycle/min 27W x 2 pcs + 3.4W
Circuit Breaker: Type Amperage for Individual Circuit x Quantity: MAIN HEADLIGHT SIGNAL IGNITION RESERVE	Fuse 30A x 1 pcs. 20A x 1 pcs. 10A x 1 pcs. 10A x 1 pcs. 30A x 1 pcs, 10A x 1 pcs.



Tightening torque chart

Part to be tightened	Part name	Thread size	Q'ty	Tightening torque			Remarks
				Nm	m · kg	ft · lb	
Cam shaft cap	Bolt	M6 P1.0	24	10	1.0	7.2	Tighten in 3-stages
Cylinder (cam chain)	Stud bolt	M6 P1.0	4	5	0.5	3.6	Apply oil
Cylinder (cam chain)	Nut	M6 P1.0	4	10	1.0	7.2	
Cylinder head (Exhaust pipe)	Stud bolt	M6 P1.0	8	10	1.0	7.2	Apply oil
Cylinder and crankcase	Nut	M8 P1.25	1	20	2.0	14	
Cylinder head	Cap nut	M8 P1.25	12	22	2.2	16	Apply oil
Spark plug		M12 P1.25	4	17.5	1.75	13	
Cylinder head cover	Bolt	M6 P1.0	12	10	1.0	7.2	
Cylinder	Stud bolt	M8 P1.25	1	15	1.5	11	Apply oil
Connecting rod and rod cap	Nut	M7 P0.75	8	25	2.5	18	
Camshaft and sprocket	Bolt	M7 P1.0	4	24	2.4	17	
Cam chain tensioner stopper bolt	Bolt	M8 P1.0	1	8	0.8	5.7	
Cam chain tensioner case and cylinder	Bolt	M6 P1.0	2	10	1.0	7.2	
Cam chain tensioner case lock nut	Nut	M8 P1.25	1	9	0.9	6.5	
Crankcase	Plug	M10 P1.25	1	10	1.0	7.2	
Rotor housing and pump cover	Screw	M6 P1.0	1	7	0.7	5.1	
Oil pump ass'y and crankcase	Screw	M6 P1.0	3	7	0.7	5.1	
Strainer housing and crankcase	Bolt	M6 P1.0	2	10	1.0	7.2	
Strainer cover and crankcase	Bolt	M6 P1.0	12	10	1.0	7.2	
Filter cover and crankcase	Union bolt	M20 P1.5	1	15	1.5	11	
Drain bolt	Plug	M14 P1.5	1	43	4.3	31	
Carburetor joint and cylinder head	Bolt	M6 P1.0	8	10	1.0	7.2	
Air filter cover	Screw	M5 P0.8	4	5	0.5	3.6	
Air filter case	Bolt	M6 P1.0	3	7	0.7	5.1	
Exhaust pipe and cylinder head	Nut	M6 P1.0	8	10	1.0	7.2	
Exhaust pipe joint	Bolt	M8 P1.25	6	20	2.0	14	
Muffler	Bolt	M10 P1.25	2	25	2.5	18	
Crankcase	Stud bolt	M8 P1.25	12	13	1.3	9.4	Apply oil
Crankcase (upper and lower)	Bolt	M8 P1.25	11	24	2.4	17	Apply oil
Crankcase (upper and lower)	Bolt	M6 P1.0	23	12	1.2	8.7	Apply oil

MAINTENANCE SPECIFICATIONS



Part to be tightened	Part name	Thread size	Q'ty	Tightening torque			Remarks
				Nm	m · kg	ft · lb	
Generator cover and crankcase	Bolt	M6 P1.0	3	10	1.0	7.2	
Bearing cover plate (crankcase right)	Screw	M6 P1.0	4	8	0.8	5.7	
Clutch cable holder	Screw	M6 P1.0	1	10	1.0	7.2	
Crankcase cover	Bolt	M6 P1.0	13	10	1.0	7.2	
Crankcase (Main gallery blind plug)	Plug	M20 P1.5	2	12	1.2	8.7	Apply oil
Clutch pressure plate	Bolt	M6 P1.0	5	8	0.8	5.8	
Clutch boss	Nut	M20 P1.0	1	70	7.0	50	
Drive sprocket	Bolt	M6 P1.0	2	10	1.0	7.2	
Stopper plate	Screw	M5 P0.8	1	4	0.4	2.9	Use LOCTITE®
Cam segment	Bolt	M6 P1.0	1	10	1.0	7.2	Use LOCTITE®
Change pedal	Bolt	M6 P1.0	1	10	1.0	7.2	
A.C. magneto	Bolt	M10 P1.25	1	80	8.0	58	
Stator	Bolt	M6 P1.0	3	10	1.0	7.2	Use LOCTITE®
Pickup coil base	Screw	M6 P1.0	2	8	0.8	5.8	
Starter motor	Bolt	M6 P1.0	2	10	1.0	7.2	
Neutral switch	Screw	M5 P0.8	3	3.5	0.35	2.5	Use LOCTITE®
Oil level gauge switch	Bolt	M6 P1.0	2	7	0.7	5.1	
Relief valve and crankcase	—		1	20	2.0	14	
HY-VO chain tensioner	Bolt	M6 P1.0	2	10	1.0	7.2	Use LOCTITE®
Primary drive gear	Nut	M16 P1.5	1	50	5.0	36	
Bearing cover plate	Screw	M6 P1.0	2	10	1.0	7.2	Use LOCTITE®
Starter clutch	Bolt	M8 P1.25	3	25	2.5	18	Use LOCTITE®
Shift shaft stopper	Screw	M8 P1.25	1	22	2.2	16	
Shift cam bearing plate	Screw	M6 P1.0	1	10	1.0	7.2	

ELECTRICAL

YX600W/WC CIRCUIT DIAGRAM

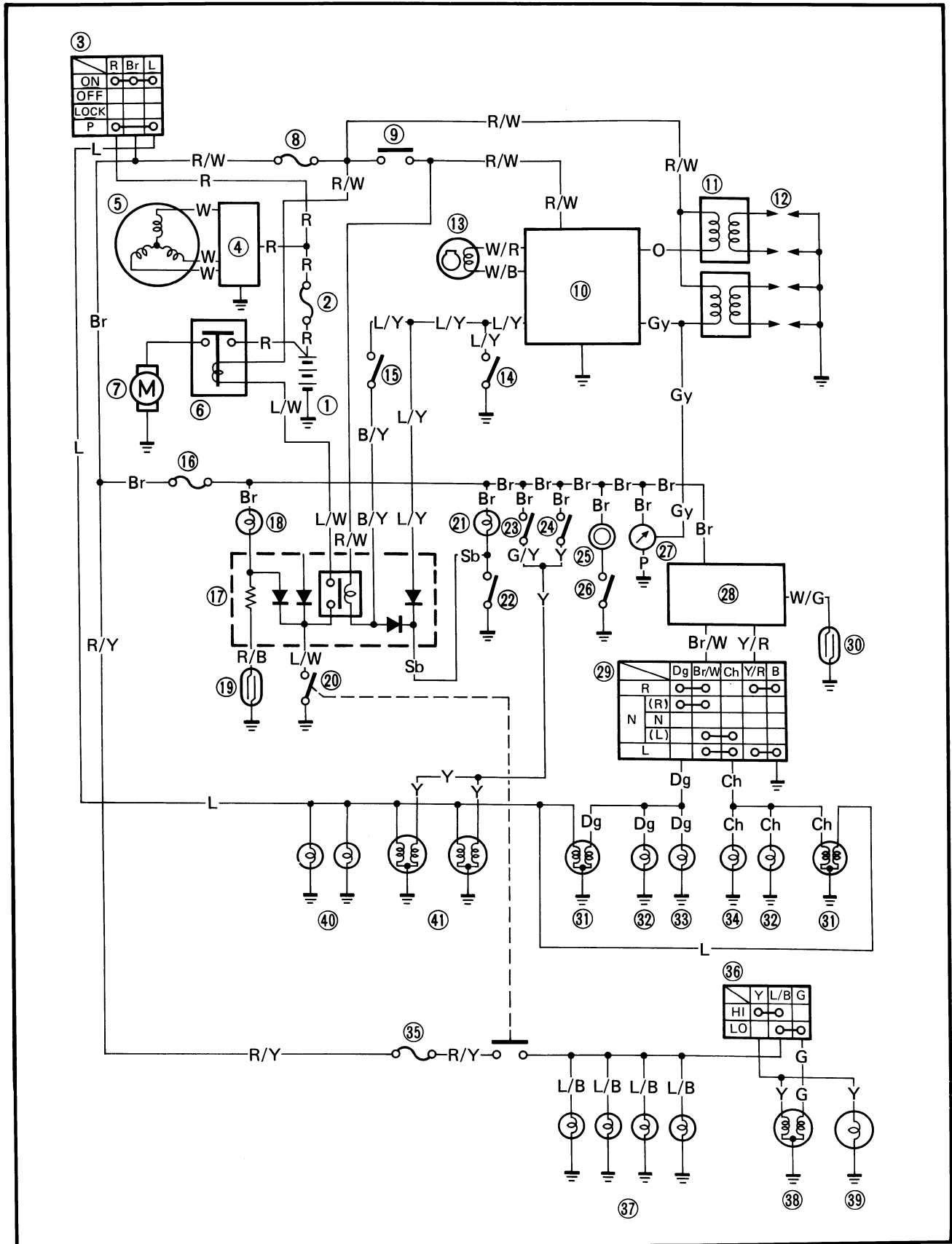



- ① Battery
- ② Fuse (Main)
- ③ "MAIN" switch
- ④ Rectifier/Regulator
- ⑤ A.C. Magneto
- ⑥ Starter relay
- ⑦ Starter motor
- ⑧ Fuse (Ignition)
- ⑨ "ENGINE STOP" switch
- ⑩ Ignitor
- ⑪ Ignition coil
- ⑫ Spark plug
- ⑬ Pick up coil
- ⑭ Sidestand switch
- ⑮ Clutch switch
- ⑯ Fuse "Signal"
- ⑰ Relay assembly
- ⑱ "OIL" indicator light
- ⑲ Oil level switch
- ⑳ "START" switch
- ㉑ "NEUTRAL" indicator light

- ㉒ Neutral switch
- ㉓ Front brake switch
- ㉔ Rear brake switch
- ㉕ Horn
- ㉖ "HORN" switch
- ㉗ Tachometer
- ㉘ Flasher relay
- ㉙ "TURN" switch
- ㉚ Reed switch
- ㉛ Front position light/Flasher light
- ㉜ Rear flasher light
- ㉝ "TURN" indicator light (Right)
- ㉞ "TURN" indicator light (Left)
- ㉟ Fuse "Head"
- ㊱ "LIGHTS" (Dimmer) switch
- ㊲ Meter light
- ㊳ Headlight
- ㊴ "HIGH BEAM" indicator light
- ㊵ Licence light
- ㊶ Tail/Brake light

COLOR CODE

O	Orange	Y/R	Yellow/Red
R	Red	Br/W	Brown/White
L	Blue	R/W	Red/White
Br	Brown	R/Y	Red/Yellow
B	Black	B/R	Black/Red
Y	Yellow	B/W	Black/White
W	White	B/Y	Black/Yellow
G	Green	L/W	Blue/White
P	Pink	L/B	Blue/Black
Dg	Dark green	L/Y	Blue/Yellow
Ch	Chocolate	G/Y	Green/Yellow
Gy	Gray	W/R	White/Red
Sb	Sky blue	W/G	White/Green

**IGNITION SYSTEM
CIRCUIT DIAGRAM**

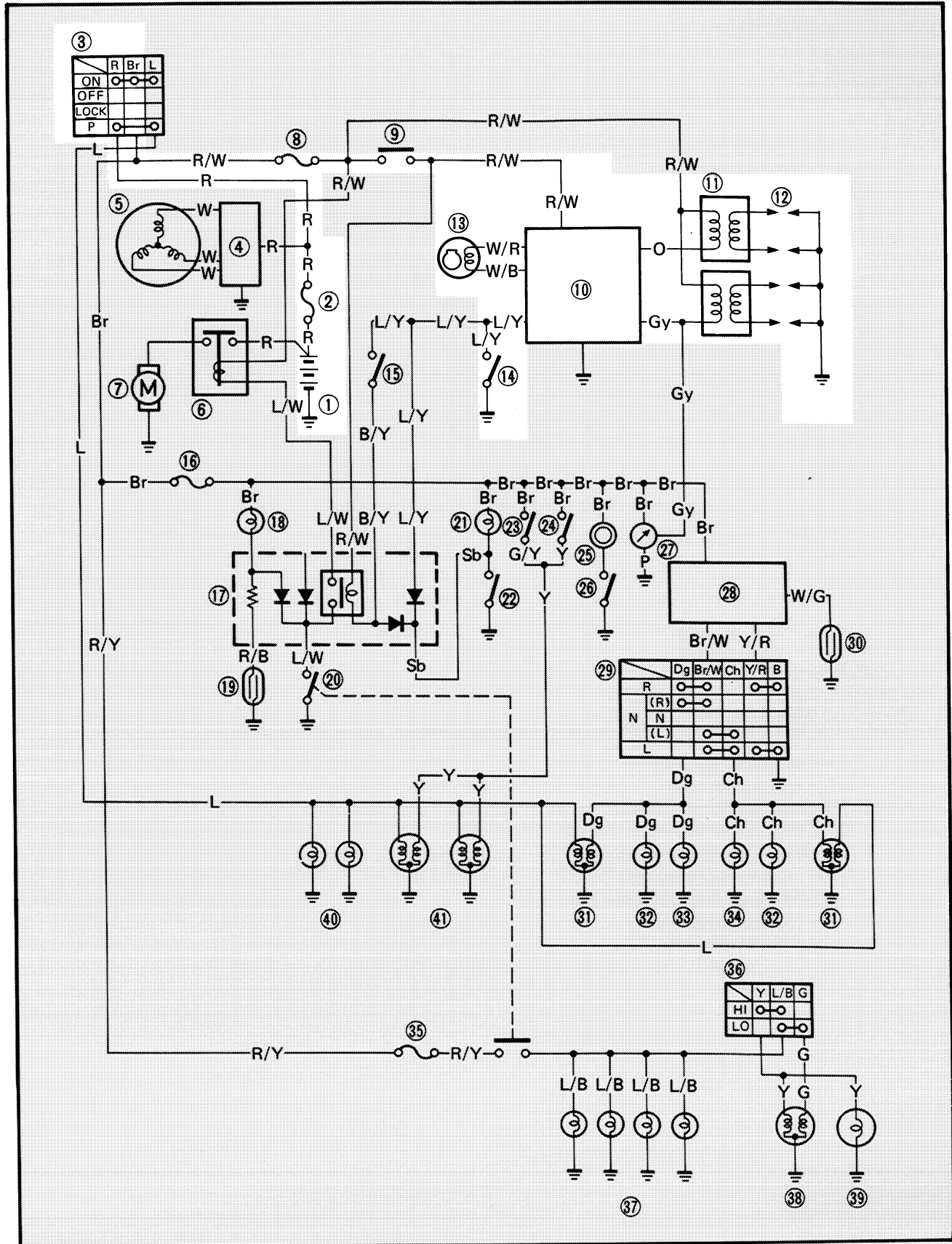

IGNITION SYSTEM



- ① Battery
- ② Fuse (MAIN)
- ③ Main switch
- ⑧ Fuse (IGNITION)
- ⑨ "ENGINE STOP" switch

- ⑩ Ignitor unit
- ⑪ Ignition coil
- ⑫ Spark plug
- ⑬ Pickup coil
- ⑭ Sidestand switch

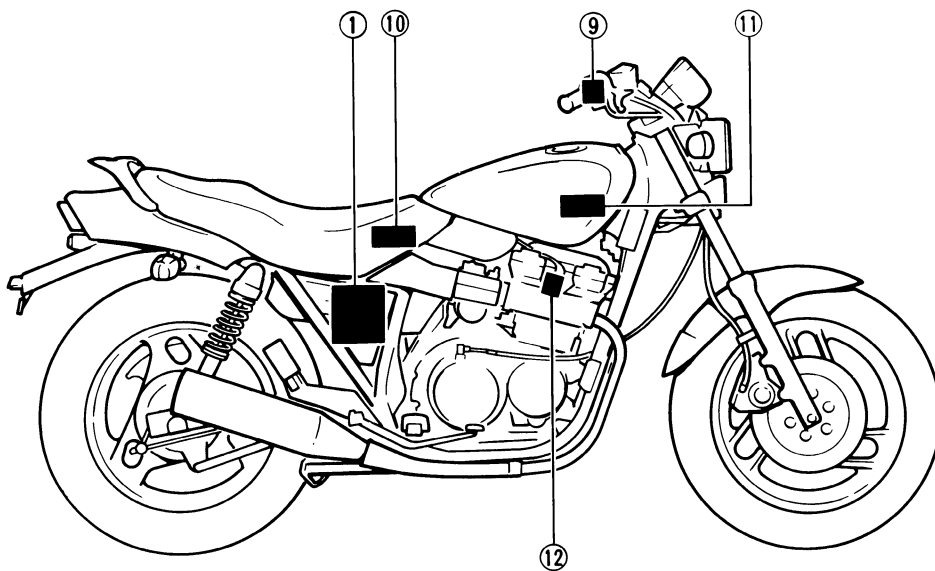
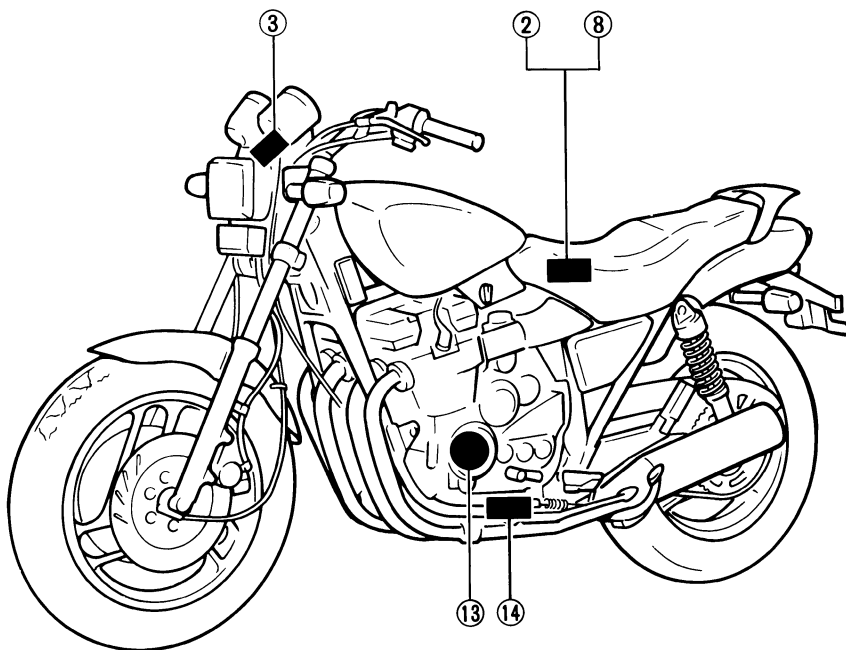

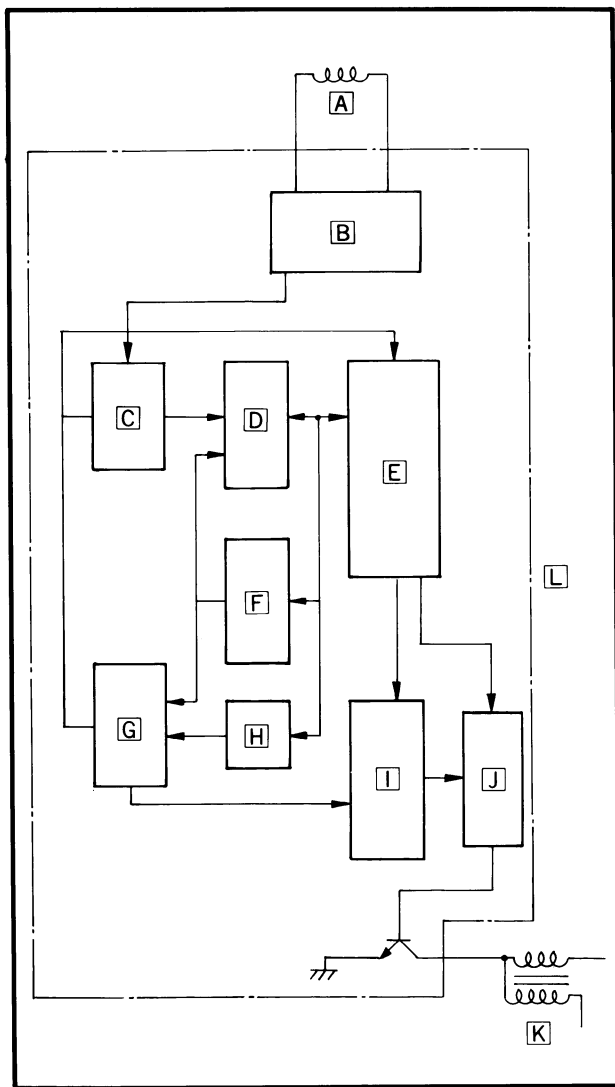

DIGITAL IGNITION CONTRL SYSTEM

DESCRIPTION

The electronic ignition that sparks the engine is computer controlled and operated by the digital microprocessor. It has a pre-programed ignition advance curve.

This programed advance curve closely matches the spark timing to the engine's ignition requirements. Only one pickup coil is needed to meet the requirements of the digital ignitor unit.

The digital ignitor also includes the control unit for the electric fuel pump.

- A** Pickup coil
- B** Wave-shape shaping circuit
- C** Edge detection circuit
- D** Latch circuit
- E** Microprocessor
- F** Free-running counter
- G** Comparison circuit
- H** Register
- I** Flip-flop circuit
- J** Driving circuit
- K** Ignition coil
- L** Digital ignitor unit

OPERATION

The following operations are digitally-performed by signal from the pickup coil signal:

1. Determing proper ignition timing.
2. Sensing the engine revolution speed.
3. Determing timing for switching on ignition coil (duty control).
4. Increasing ignition coil primary current for starting the engine.
5. Sensing engine stall.
6. Preventing over-revolution of the engine.