



YX600S

YX600SC

OWNER'S MANUAL

LIT-11626-05-06

1UJ-28199-10

www.badrab600.com

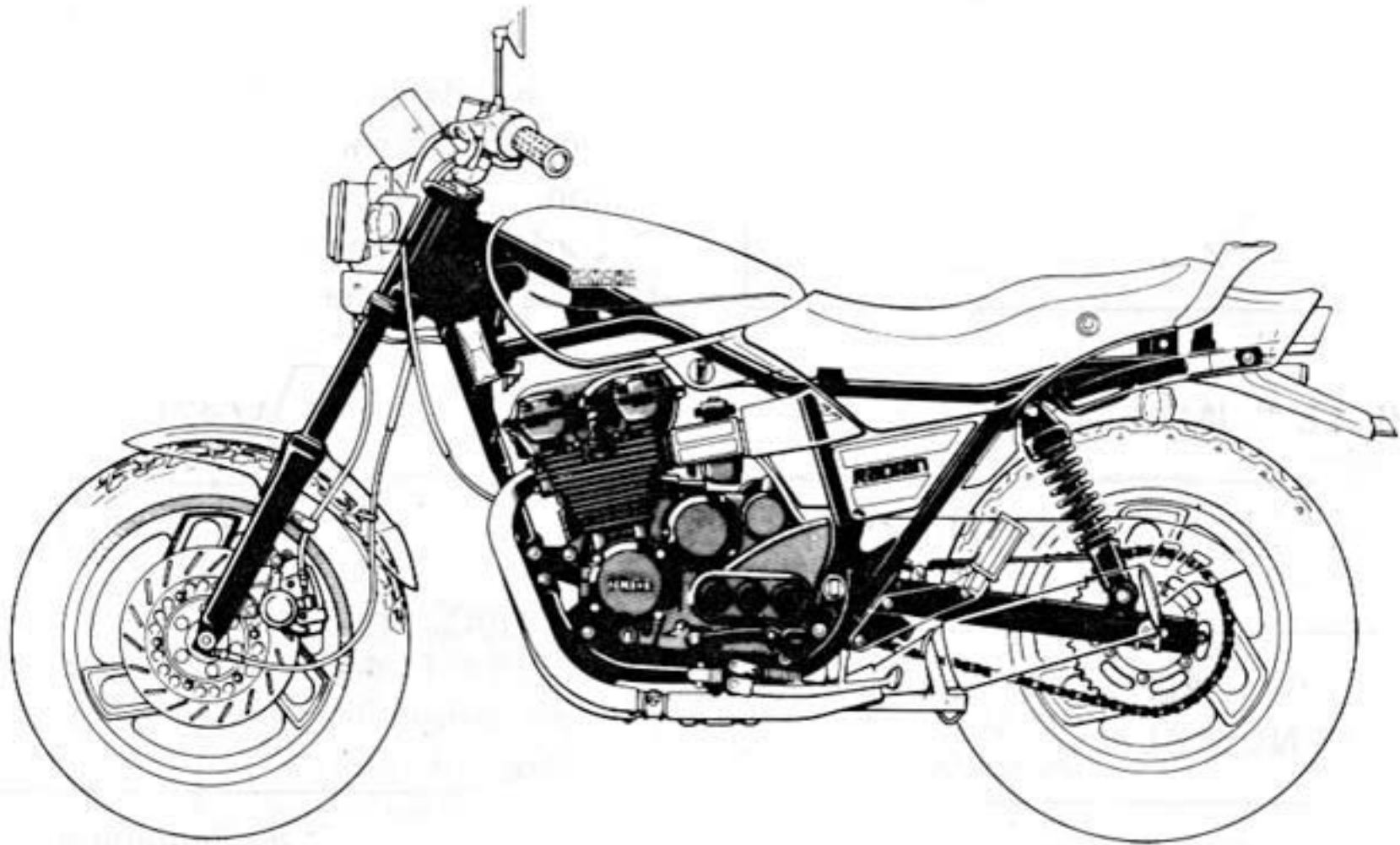

IDENTIFICATION NUMBERS RECORD

1. KEY NUMBER:

2. VEHICLE NUMBER:

3. ENGINE NUMBER:

Your key identification number is stamped on your key as shown in the following illustration.

Record this number in the space provided for reference if you need a new key.

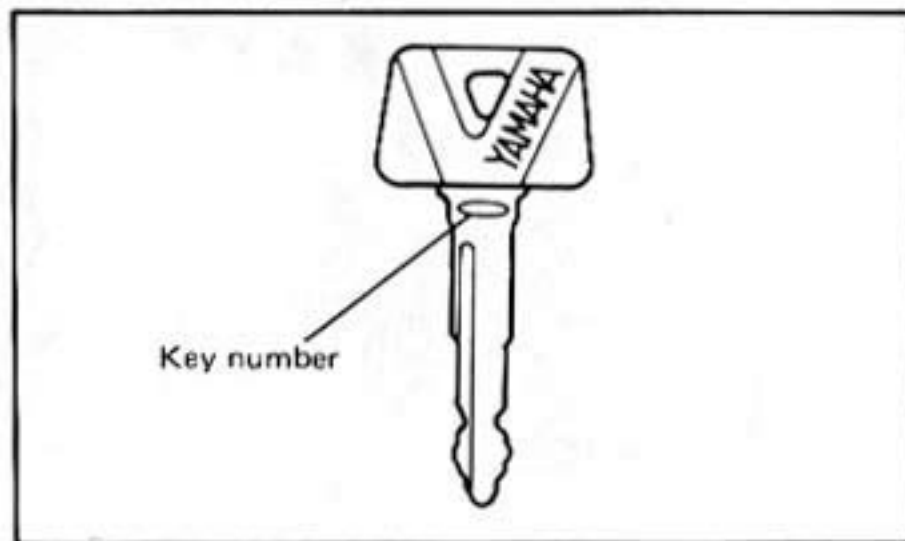

Record your vehicle and engine numbers in the spaces provided to assist you in ordering spare parts from your Yamaha dealer or for reference in case your vehicle is stolen. (See page 2-1)

A-000

**YX600S/YX600SC
OWNER'S MANUAL**

**©1985 by Yamaha Motor Corporation, U.S.A.
1st Edition, November 1985**

**All rights reserved. Any reprinting or
unauthorized use without the written
permission of Yamaha Motor Corporation,
U.S.A. is expressly prohibited.**

Printed in Japan

P/N LIT-11626-05-06

INTRODUCTION

Congratulations on your purchase of the Yamaha YX600S/YX600SC. This model is the result of Yamaha's vast experience in the production of fine sporting, touring, and pacesetting racing machines. It represents the high degree of craftsmanship and reliability that have made Yamaha a leader in these fields.

This manual will give you an understanding of the operation, inspection, and basic maintenance of this motorcycle. If you have any questions about the operation or maintenance of your motorcycle, please consult a Yamaha dealer.

U-001

NOTE: _____

Some data in this manual may become outdated due to future improvement on this model. If you have any questions about this manual or your motorcycle, please consult a Yamaha dealer.

This Yamaha Motorcycle in its design and manufacture fully complies with the emissions standards for clean air applicable at the date of manufacture. Yamaha has met these standards without reducing the motorcycle's performance or economy of operation. To maintain these high standards, it is important that you and your dealer pay close attention to the recommended maintenance schedules and operating instructions contained within this manual.

**TECHNICAL PUBLICATIONS
SERVICE DIVISION
MOTORCYCLE OPERATIONS
YAMAHA MOTOR CO., LTD.**

WARNING:

PLEASE READ THIS MANUAL CAREFULLY AND COMPLETELY BEFORE OPERATING THIS MOTORCYCLE. DO NOT ATTEMPT TO OPERATE THIS MOTORCYCLE UNTIL YOU HAVE ATTAINED A SATISFACTORY KNOWLEDGE OF ITS CONTROLS AND OPERATING FEATURES AND UNTIL YOU HAVE BEEN TRAINED IN SAFE AND PROPER RIDING TECHNIQUES. REGULAR INSPECTIONS AND CAREFUL MAINTENANCE, ALONG WITH GOOD RIDING SKILLS, WILL ENSURE THAT YOU SAFELY ENJOY THE CAPABILITIES AND THE RELIABILITY OF THIS MOTORCYCLE.

Particularly important information is distinguished in this manual by the following notations:

NOTE:

A NOTE provides key information to make procedures easier or clearer.

CAUTION:

A CAUTION indicates special procedures that must be followed to avoid damage to the motorcycle.

WARNING:

A WARNING indicates special procedures that must be followed to avoid injury to a motorcycle operator or person inspecting or repairing the motorcycle.

U-000

NOTE:

This manual should be considered a permanent part of this motorcycle and should remain with it even if the motorcycle is subsequently sold.

SAFETY WARNINGS:

- 1. Traffic regulations vary from state (jurisdiction) to state (jurisdiction). Study the regulations in your area before riding this motorcycle.**
- 2. This motorcycle is designed for on-road use only. It is not suitable for off-road use.**
- 3. GASOLINE IS HIGHLY FLAMMABLE:**
 - * Always turn off the engine when refuelling.**
 - * Take care not to spill any gasoline on the engine or exhaust pipe(s)/muffler(s) when refuelling.**
 - * Never refuel while smoking or in the vicinity of an open flame.**
- 4. If you should swallow some gasoline, inhale a lot of gasoline vapor, or allow some gasoline to get in your eye(s), see your doctor immediately. If any gasoline spills on your skin or clothing, immediately wash it with soap and water and change your clothes.**
- 5. Always turn off the engine before leaving the motorcycle unattended and do not forget to remove the ignition key. When parking the motorcycle, note the following:**
 - * The engine and exhaust pipe(s)/muffler(s) may be hot. Park the motorcycle in a place where pedestrians or children are not likely to touch the motorcycle.**
 - * Do not park the motorcycle on a slope or soft ground; the motorcycle may overturn.**

- 6. When transporting the motorcycle in another vehicle, be sure it is kept upright and that the fuel cock(s) is turned to "ON" or "RES" (for vacuum type)/"OFF" (for manual type). If it should lean over, gasoline may leak out of the carburetor or fuel tank.**
- 7. Never start your engine or let it run for any length of time in a closed area. The exhaust fumes are poisonous and may cause loss of consciousness and death within a short time. Always operate your motorcycle in an area with adequate ventilation.**
- 8. Always wear a helmet, gloves, trousers (tapered around the cuff and ankle so they do not flap), and a brightly colored jacket.**
- 9. This motorcycle is designed for use as a two-wheeled vehicle capable of carrying a rider and a passenger. The total weight of the rider, passenger, accessories, and cargo must not exceed the maximum load limit (See page 5-5.)**
- 10. Be sure that the rider's and passenger's feet are on the footrests during operation.**
- 11. It is important in maintaining control of the vehicle to keep the rider's hands on the handlebars at all time.**

CONTENTS

| | | | |
|--|-----|--|------|
| LOCATION OF THE IMPORTANT LABELS | 1-1 | Clutch lever | 4-6 |
| DESCRIPTION | 2-1 | Change pedal | 4-6 |
| MOTORCYCLE IDENTIFICATION | 3-1 | Front brake lever..... | 4-7 |
| Vehicle identification number | 3-1 | Rear brake pedal..... | 4-7 |
| Engine serial number..... | 3-1 | Fuel tank cap | 4-7 |
| CONTROL FUNCTIONS..... | 4-1 | Fuel cock | 4-7 |
| Main switch..... | 4-1 | Starter lever (CHOKE)..... | 4-8 |
| Indicator lights | 4-2 | Steering lock..... | 4-9 |
| Oil level indicator circuit check..... | 4-3 | Seat lock..... | 4-10 |
| Speedometer | 4-4 | Helmet holder | 4-10 |
| Tachometer..... | 4-4 | Rear shock absorber | 4-11 |
| Handlebar switches..... | 4-5 | Sidestand..... | 4-11 |
| “LIGHTS” (Dimmer) switch | 4-5 | Sidestand/clutch switch operation check..... | 4-12 |
| “TURN” signal switch | 4-5 | PRE-OPERATION CHECKS | 5-1 |
| “HORN” switch | 4-5 | Brakes..... | 5-3 |
| “ENGINE STOP” switch | 4-6 | Brake fluid leakage (Front) | 5-3 |
| “START” switch | 4-6 | Clutch | 5-4 |
| | | Throttle grip..... | 5-4 |
| | | Engine oil..... | 5-4 |

| | |
|---------------------------------------|------|
| Chain | 5-5 |
| Tires | 5-5 |
| Tubeless tires and cast wheels..... | 5-7 |
| Accesories or replacement parts | 5-9 |
| Fittings/Fasteners..... | 5-9 |
| Lights and signals | 5-10 |
| Switches..... | 5-10 |
| Battery | 5-10 |
| Fuel..... | 5-10 |
| Fuel tank breather hose..... | 5-11 |

OPERATION AND IMPORTANT

| | |
|---|-----|
| RIDING POINTS | 6-1 |
| Starting and warming up a cold engine..... | 6-2 |
| Starting a warm engine..... | 6-5 |
| Shifting | 6-5 |
| To start out and accelerate..... | 6-6 |
| To decelerate | 6-6 |
| Recommended shift point..... | 6-6 |
| Engine break-in | 6-7 |
| Parking | 6-7 |

PERIODIC MAINTENANCE AND

| | |
|--|------|
| MINOR REPAIR..... | 7-1 |
| Periodic maintenance..... | 7-1 |
| Tool kit..... | 7-2 |
| Periodic maintenance emission control system | 7-3 |
| Spark plug inspection | 7-5 |
| Canister (for California only) | 7-6 |
| General maintenance/lubrication..... | 7-7 |
| Torque specifications | 7-10 |
| Engine oil..... | 7-11 |
| Air filter | 7-14 |
| Carburetor adjustment..... | 7-16 |
| Front brake adjustment | 7-16 |
| Rear brake adjustment..... | 7-17 |
| Brake light switch adjustment..... | 7-18 |
| Checking the front brake pads and rear brake shoes..... | 7-19 |
| Inspecting the brake fluid level | 7-20 |
| Brake fluid replacement | 7-21 |
| Clutch adjustment | 7-21 |
| Free play adjustment | 7-22 |
| Drive chain slack check..... | 7-23 |

| | | | |
|--|------|-----------------------------------|-------------|
| Drive chain slack adjustment | 7-23 | Troubleshooting chart | 7-43 |
| Drive chain lubrication | 7-25 | | |
| Cable inspection and lubrication | 7-25 | CLEANING AND STORAGE | 8-1 |
| Throttle cable and grip lubrication | 7-26 | A. Cleaning | 8-1 |
| Brake and change pedals | 7-26 | B. Storage..... | 8-2 |
| Brake and clutch levers | 7-26 | | |
| Center and sidestand..... | 7-26 | MISCELLANEOUS..... | 9-1 |
| Rear suspension | 7-27 | | |
| Front fork oil change | 7-27 | SPECIFICATIONS..... | 10-1 |
| Rear shock absorber adjustment..... | 7-29 | | |
| Steering inspection | 7-30 | WARRANTY INFORMATION | 11-1 |
| Wheel bearings..... | 7-31 | | |
| Battery | 7-31 | MOTORCYCLE NOISE | |
| Replenishing the battery fluid | 7-32 | REGURATION..... | 12-1 |
| Fuse replacement | 7-33 | | |
| Replacing the headlight bulb..... | 7-34 | MAINTENANCE RECORD | 13-1 |
| Headlight beam adjustment | 7-36 | | |
| Taillight bulb replacement..... | 7-37 | WIRING DIAGRAM | |
| Front wheel removal..... | 7-38 | | |
| Front wheel installation..... | 7-39 | | |
| Rear wheel removal..... | 7-40 | | |
| Rear wheel installation | 7-41 | | |
| Troubleshooting | 7-42 | | |

LOCATION OF THE IMPORTANT LABELS

Please read following labels carefully before operating this motorcycle.

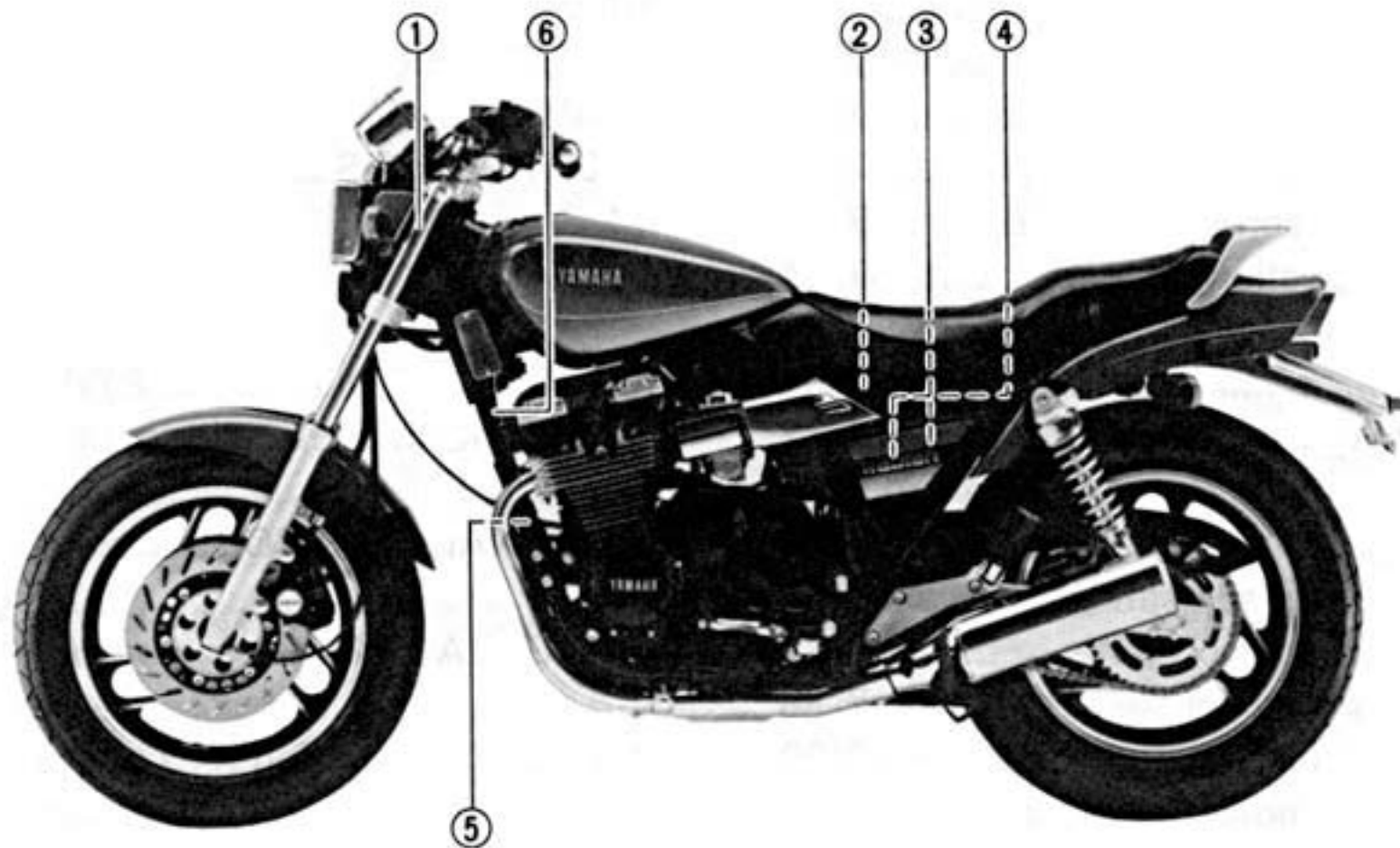

① MFD, BY YAMAHA MOTOR CO., LTD, (Month/Year) GVWR xxx LBS. GAWR FRONT – xxx LBS. WITH xxxxx TIRE. xxxxx RIM, AT xx PSI COLD. REAR – xxx LBS. WITH xxxxx TIRE, xxxxx RIM, AT xx PSI COLD.
 THIS VEHICLE CONFORMS TO ALL APPLICABLE FEDERAL MOTOR VEHICLE SAFETY STANDARDS IN EFFECT ON THE DATE OF MANUFACTURE SHOWN ABOVE.
 VEHICLE ID NO. x x x x x (17 digits)
 TYPE CLASSIFICATION. MOTORCYCLE.

③ **CAUTION**
 (BATTERY REMOVAL AND INSTALLATION)
 1. Disconnect breather pipe before removing battery.
 2. After installing battery, be sure to connect breather pipe into place.

②

| VEHICLE EMISSION CONTROL INFORMATION | | THIS VEHICLE CONFORMS TO U.S. EPA AND CALIFORNIA REGULATIONS APPLICABLE TO 19** MODEL YEAR NEW MOTORCYCLES AND TO ** HC ENGINE FAMILY EXHAUST EMISSION STANDARD IN CALIFORNIA. |
|--|--------------------------|--|
| ENGINE FAMILY: **** EVAP. FAMILY: *** DISPLACEMENT: ** cc EXHAUST EMISSION CONTROL SYSTEM: EM. | | |
| ENGINE TUNE-UP SPECIFICATIONS AND ADJUSTMENTS: AT NORMAL OPERATING TEMPERATURE. PUT VEHICLE IN THE UPRIGHT POSITION, TRANSMISSION IN NEUTRAL, AND WARM UP ENGINE | | |
| ITEM | SPEC | INSTRUCTIONS |
| 1. IGNITION TIMING ** | BTOC AT IDLE SPEED | NO ADJUSTMENT |
| 2. IDLE SPEED (RPM) *** | | ADJUST THROTTLE STOP SCREW |
| 3. IDLE MIXTURE | | NO ADJUSTMENT |
| 4. VALVE CLEARANCE (MM) IN: *** EX: *** | | SEE SERVICE MANUAL |
| 5. SPARK PLUG: *** | SPARK PLUG GAP (MM): *** | |
| FUEL SPECIFICATIONS | | ENGINE LUBRICANT SPECIFICATIONS |
| GASOLINE GRADE: REGULAR (LEADED) RESEARCH OCTANE: ** MIN | | ENGINE OIL: *** |
| YAMAHA MOTOR CO., LTD.  | | |

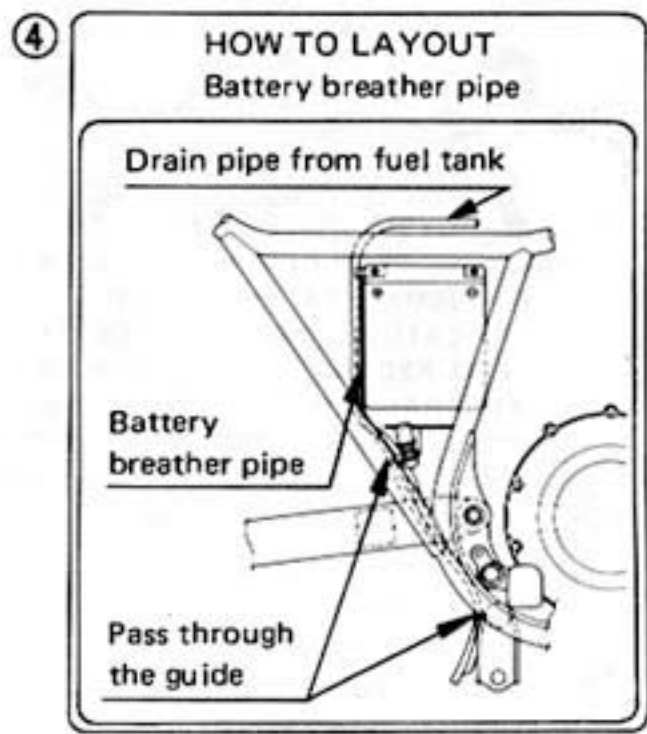

⑤ for California

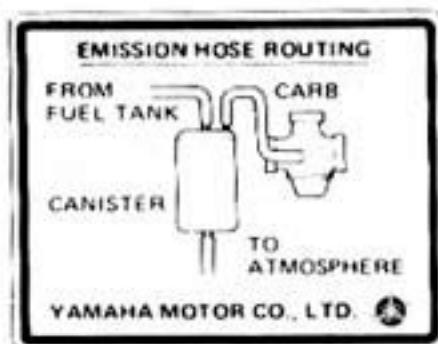

⑥ MOTOCYCLE NOISE EMISSION CONTROL INFORMATION
THIS 19xx YAM xxxxx MOTORCYCLE MEETS EPA NOISE
EMISSION REQUIREMENTS OF xx dB (A) AT xxxx RPM BY
THE FEDERAL TEST PROCEDURE.
MODIFICATIONS WHICH CAUSE THIS MOTORCYCLE TO
EXCEED FEDERAL NOISE STANDARDS ARE PROHIBITED
BY FEDERAL LAW. SEE OWNER'S MANUAL.

DESCRIPTION

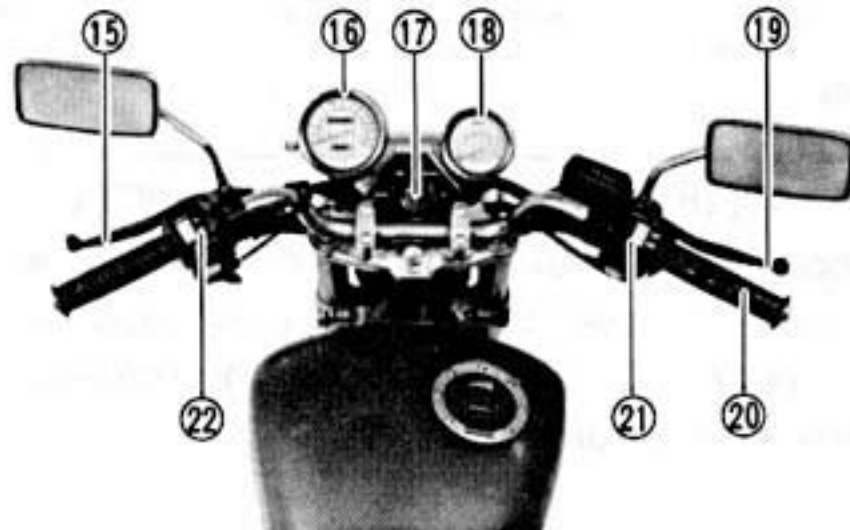
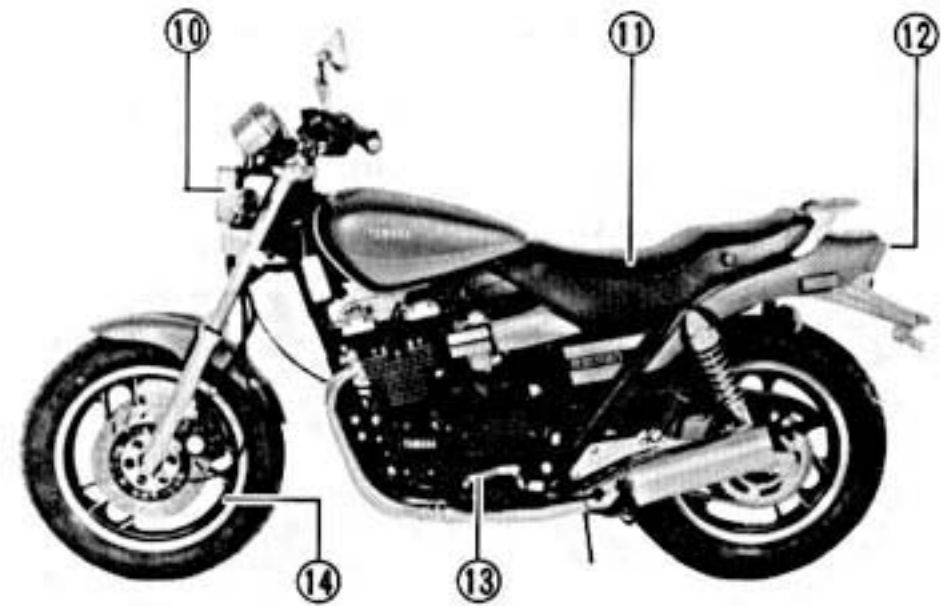
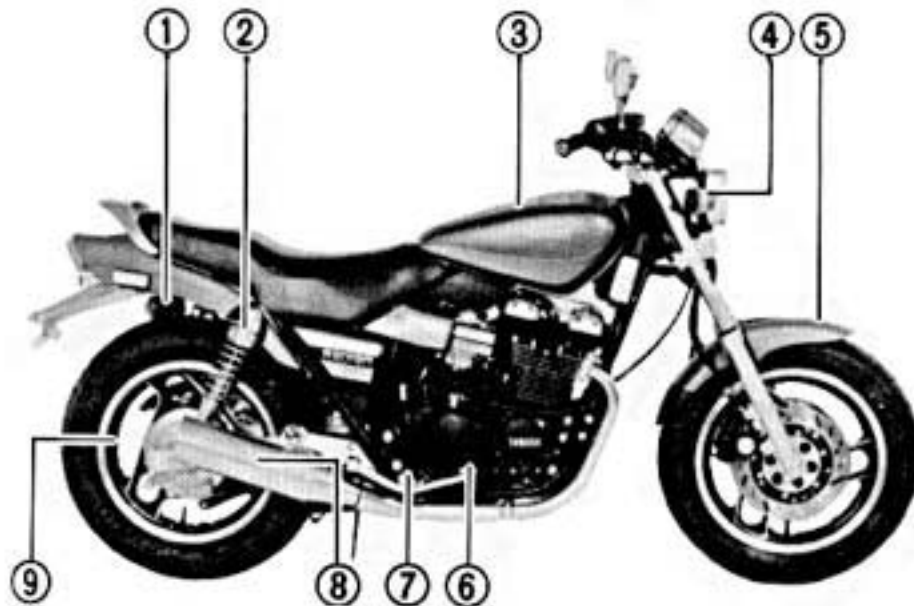

- | | |
|------------------------|----------------------------|
| 1. Rear flasher light | 12. Tail/brake light |
| 2. Rear shock absorber | 13. Change pedal |
| 3. Fuel tank | 14. Front wheel |
| 4. Front flasher light | 15. Clutch lever |
| 5. Front fender | 16. Speedometer |
| 6. Brake pedal | 17. Main switch |
| 7. Footrest | 18. Tachometer |
| 8. Silencer | 19. Brake lever |
| 9. Rear wheel | 20. Throttle grip |
| 10. Headlight | 21. Right handlebar switch |
| 11. Seat | 22. Left handlebar switch |

A-600

MOTORCYCLE IDENTIFICATION

A-800

Vehicle identification number

The vehicle identification number is stamped into the steering head pipe.

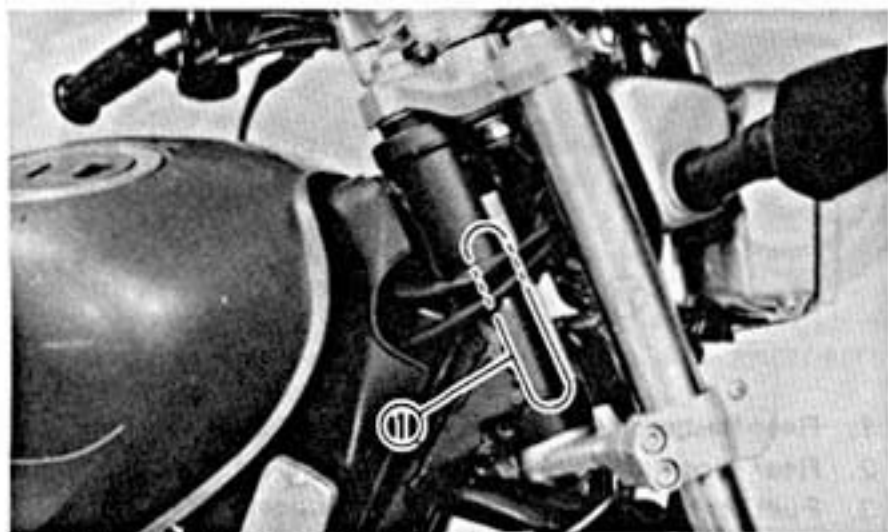

1. Vehicle identification number

U-004

NOTE: _____

The vehicle identification number is used to identify your motorcycle and may be used to register your motorcycle with the licensing authority in your state.

A-701

Engine serial number

The engine serial number is stamped into the right side of the engine.

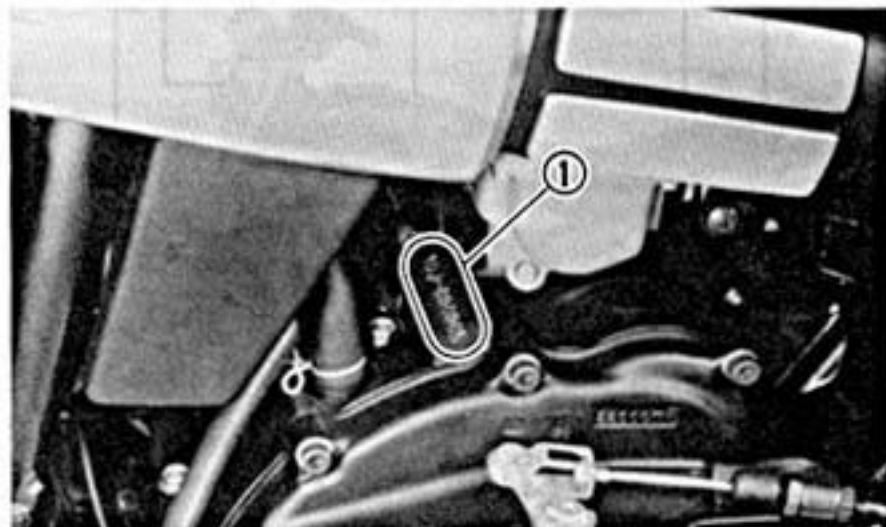

1. Engine serial number

U-003

NOTE: _____

The first three digits of these numbers are for model identification; the remaining digits are the unit production number. Keep a record of these numbers for reference when ordering parts from a Yamaha dealer.

B-000

CONTROL FUNCTIONS

B-001

Main switch

The main switch controls the ignition and lighting systems; its operation is described below.

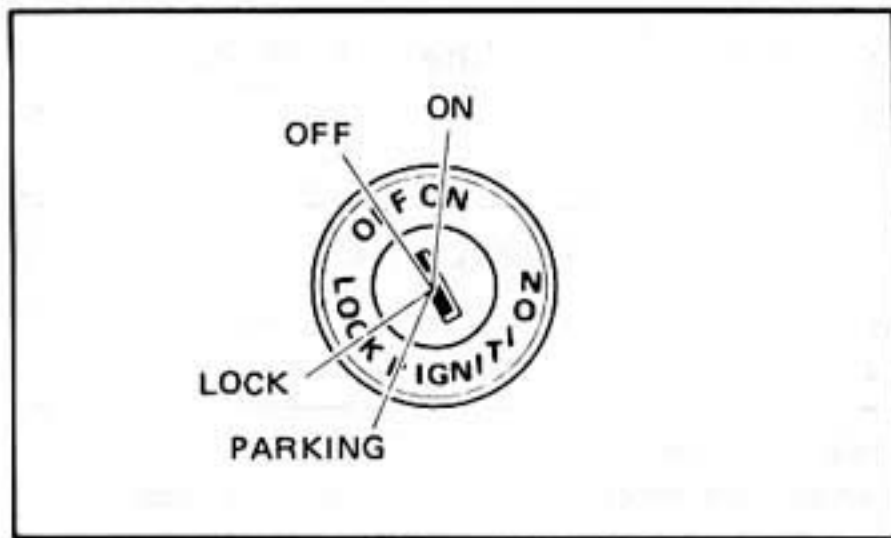

B-013

ON:

Electrical circuits are switched on, and the headlight, meter light, and taillight come on. The engine can be started. The key cannot be removed in this position.

B-006

OFF:

All electrical circuits are switched off. The key can be removed in this position.

B-007

LOCK:

The steering is locked in this position, and all electrical circuits are switched off. The key can be removed in this position. Refer to "Steering lock" (Page 4-9) for proper operation.

B-008

PARKING:

The steering is locked in this position, and the taillight comes on but all other circuits are off. The key can be removed in this position.

U-007

NOTE:

Always turn the main switch to "OFF" or "LOCK" and remove the key when the motorcycle is unattended.

B-100

Indicator lights

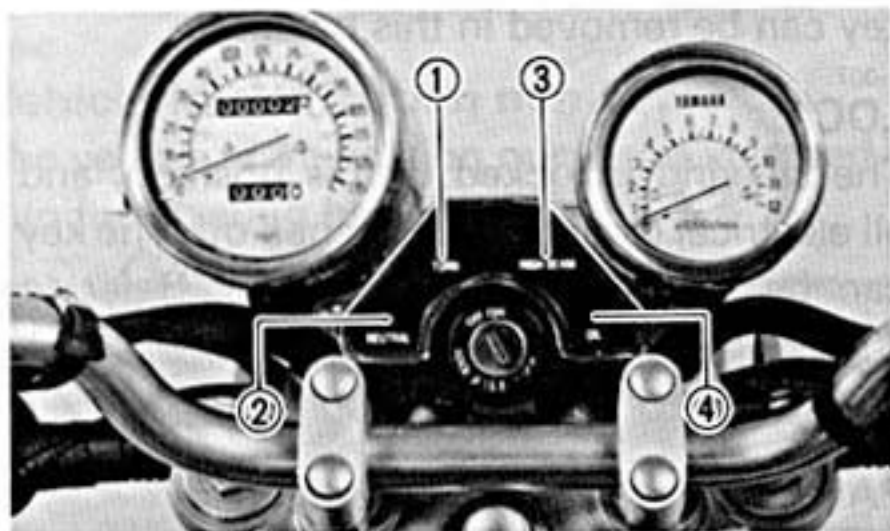

1. "TURN" indicator light
2. "NEUTRAL" indicator light
3. "HIGH BEAM" indicator light
4. "OIL" indicator light

B-101

"TURN" indicator light (orange):

This indicator flashes when the turn switch is "ON".

B-102

"NEUTRAL" indicator light (green):

This indicator comes on when the transmission is in neutral.

B-103

"HIGH BEAM" indicator light (blue):

This indicator comes on when the headlight high beam is used.

B-106

"OIL LEVEL" indicator light (red):

This indicator comes on when the oil level is low. This light circuit can be checked by the following procedure.

U-300

CAUTION:

Do not run the motorcycle until you know the motorcycle has enough engine oil.

Oil level indicator circuit check

CB3-01

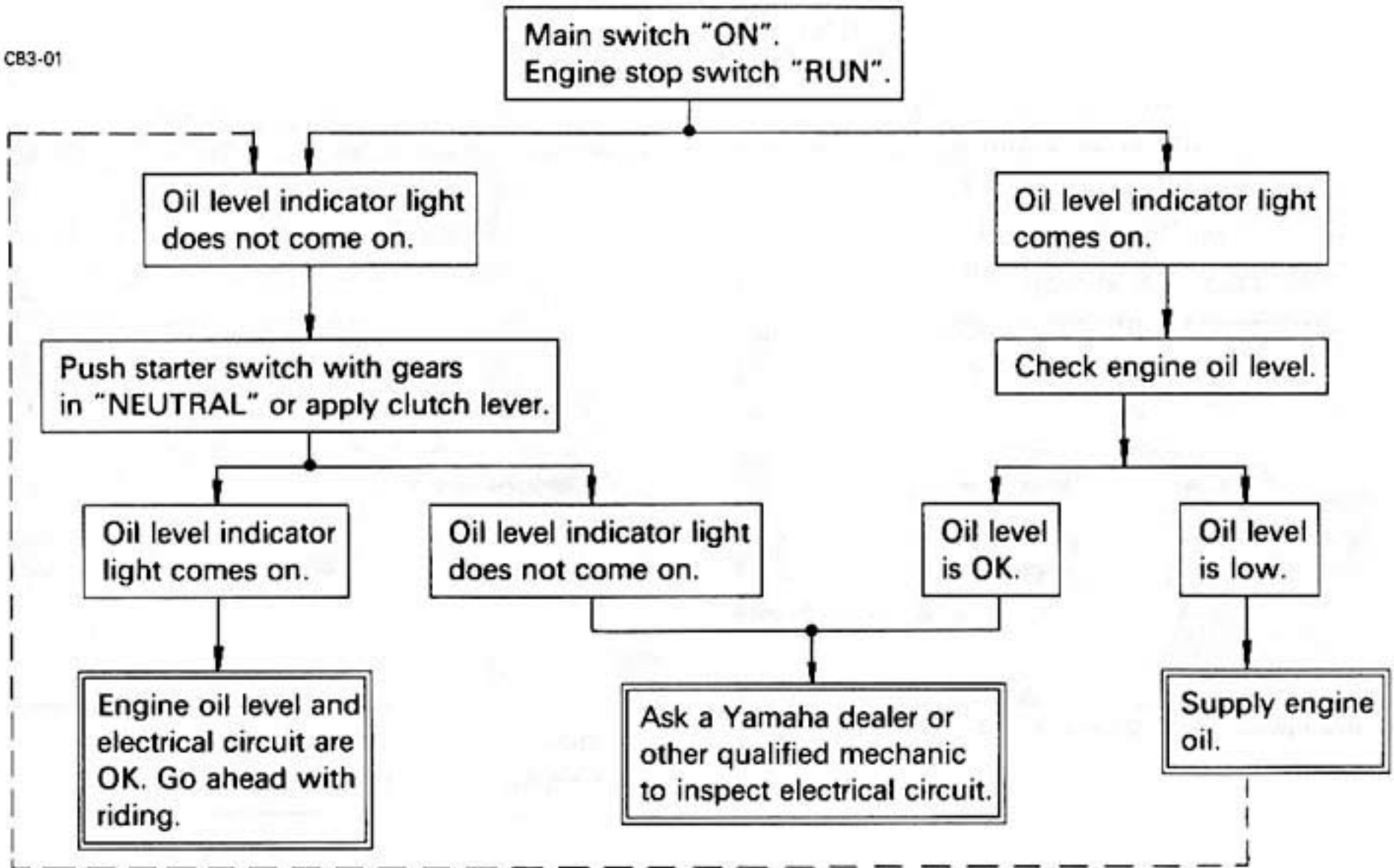

B-400

Speedometer

The odometer and trip odometer are built into the speedometer. The trip odometer can be reset to "0" with the reset switch.

Use the odometer to estimate how far you can ride on a tank of fuel before going to "RESERVE". This information will enable you to plan fuel stops in the future.

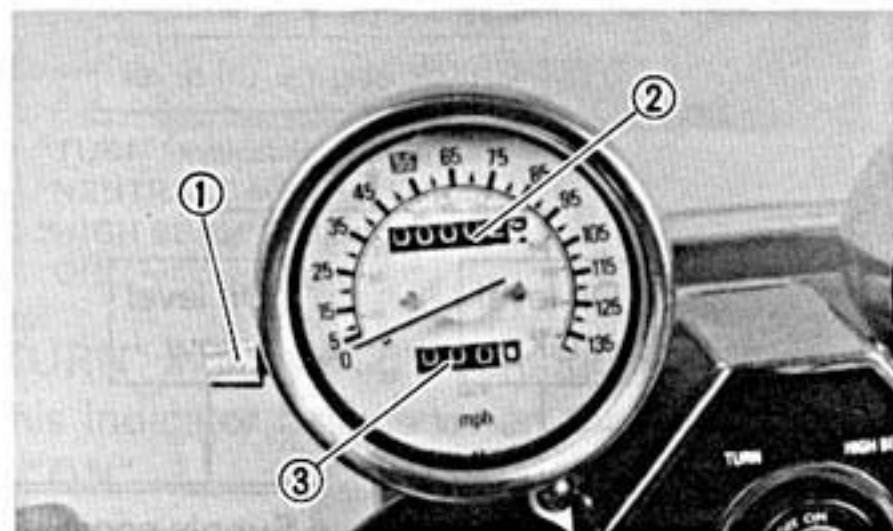

1. Reset switch 2. Odometer 3. Trip odometer

B-402

Tachometer

This model is equipped with an electric tachometer so the rider can monitor the engine speed and keep it within the ideal power range.

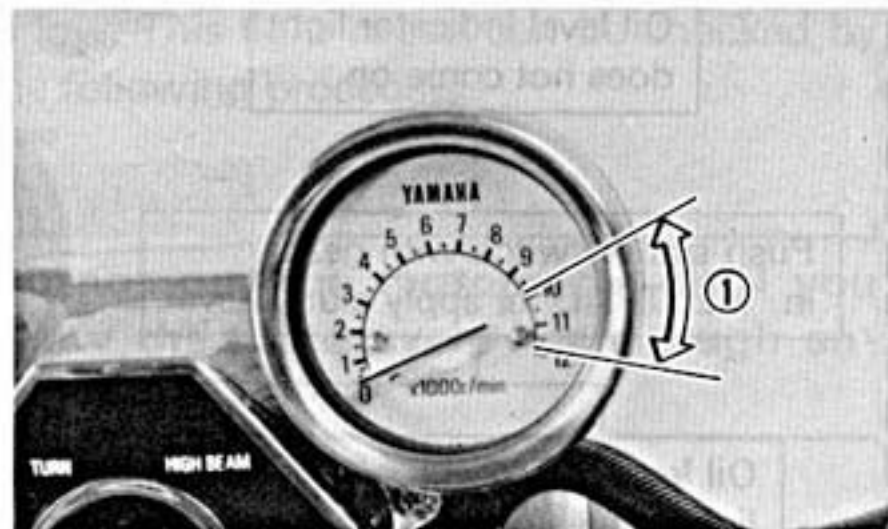

1. Red zone

U-304

CAUTION:

Do not operate in the red zone
Red zone: 10,000 r/min and above

Handlebar switches:

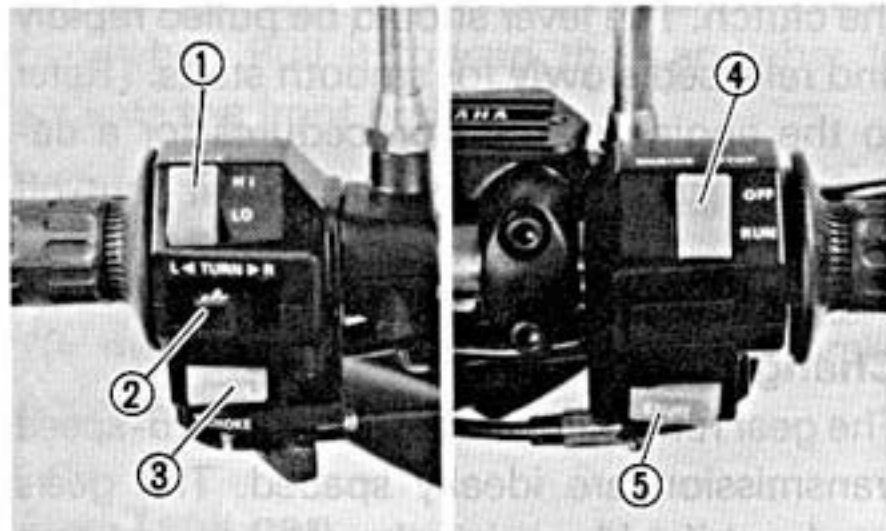

- | | |
|-----------------------------|-------------------------|
| 1. "LIGHTS" (Dimmer) switch | 4. "ENGINE STOP" switch |
| 2. "TURN" switch | 5. "START" switch |
| 3. "HORN" switch | |

"LIGHTS" (Dimmer) switch

Turn the switch to "HI" for the high beam and to "LO" for the low beam.

"TURN" signal switch

This model is equipped with self-cancelling turn signals. To signal a right-hand turn, push the switch to the right; to signal a left-hand turn, push the switch to the left. Once the switch is released it will return to the center position. To cancel the signal, push the switch in after it has returned to the center position. If the switch is not cancelled by hand, it will self-cancel after the motorcycle has travelled for about 10 seconds or approximately 150 meters (490 feet) whichever is greater. The self-cancelling mechanism only operates when the motorcycle is moving; thus the signal will not self-cancel while you are stopped at an intersection.

"HORN" switch

Press the switch to sound the horn.

B-609

"ENGINE STOP" switch

The engine stop switch is a safety device for use in an emergency such as when the motorcycle overturns or when trouble occurs in the throttle system. The engine will not run when the engine stop switch is turned to "OFF." In case of emergency, turn the switch to "OFF."

B-607

"START" switch

To start the engine, push the starter.

U-307

CAUTION:

See starting instructions prior to starting engine.

B-700

Clutch lever

The clutch lever is located on the left handlebar, and the starting circuit cut-off switch is incorporated in the clutch lever holder. Pull the clutch lever to the handlebar to disengage

the clutch, and release the lever to engage the clutch. The lever should be pulled rapidly and released slowly for smooth starts. (Refer to the engine starting procedures for a description of the starting circuit cut-off switch.)

B-800

Change pedal

The gear ratios of the constant-mesh 6-speed transmission are ideally spaced. The gears can be shifted by using the change pedal on the left side of the engine.

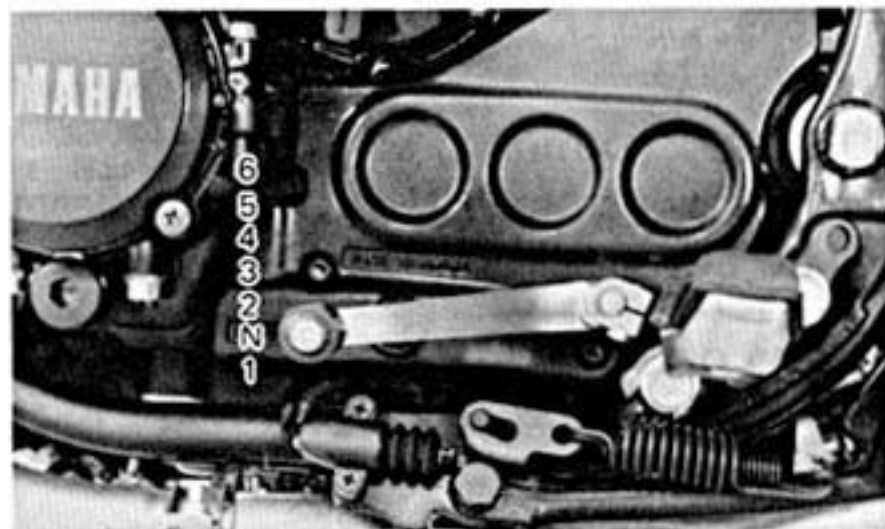

N, Neutral

B-900

Front brake lever

The front brake lever is located on the right handlebar. Pull it toward the handlebar to activate the front brake.

B-901

Rear brake pedal

The rear brake pedal is on the right side of the motorcycle. Press down on the brake pedal to activate the rear brake.

C-005K

Fuel Tank cap

TO OPEN:

Open the key cover. Insert the key and turn clockwise 1/4 turn. The lock will be released and the cap can be opened.

TO CLOSE:

Push the tank cap into position with the key inserted. To remove the key, turn it counter clockwise to the original position. Then, close the key cover.

U-012

NOTE: _____

This tank cap cannot be closed unless the key is in the lock. The key cannot be removed if the cap is not locked properly.



1. Open

C-102

Fuel cock

The negative pressure fuel cock supplies fuel from the tank to the carburetors and also filters the fuel. The fuel cock has the following three positions:

- ON:** With the lever in this position, fuel flows if the engine is running but stops if the engine is not running.
- RES:** This indicates reserve. If you run out of fuel while riding, move the lever to "PRI", start the engine, then switch to "RES". FILL THE TANK AT THE FIRST OPPORTUNITY. BE SURE TO SET THE LEVER TO "ON" AFTER REFUELING.



U-014

NOTE: _____
The fuel cock operates on vacuum from the engine when set at "ON" or "RES." If the line connecting the cock to the carburetor intake manifold is not connected or has a leak, the cock will not function properly.

PRI: This indicates prime. With the lever in this position, fuel flows whether the engine is running or not. If the fuel tank is completely empty, refill the tank, prime the carburetor in this position, and then switch to "ON" after starting the engine.

C-201

Starter lever (CHOKE)

The starter lever is located on the left handlebar.

Starting a cold engine requires a richer fuel mixture. In such a case, turn the starter lever to the left. After the engine is warm, turn the lever to its original position.

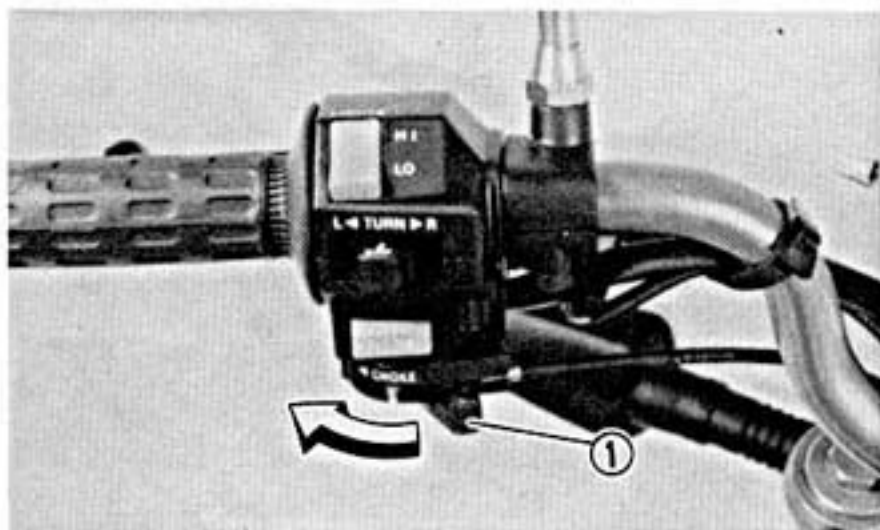

1. Starter lever (CHOKE)

U-016

NOTE:

Refer to "Starting and warming up a cold engine" for proper operation.

C-300

Steering lock

The steering is locked when the main switch is turned to "LOCK." To lock the steering, turn the handlebars all the way to the left or right. With the key at "OFF," push it into the main switch, turn the key counterclockwise to "LOCK," and remove the key. To release the lock, turn the key clockwise.

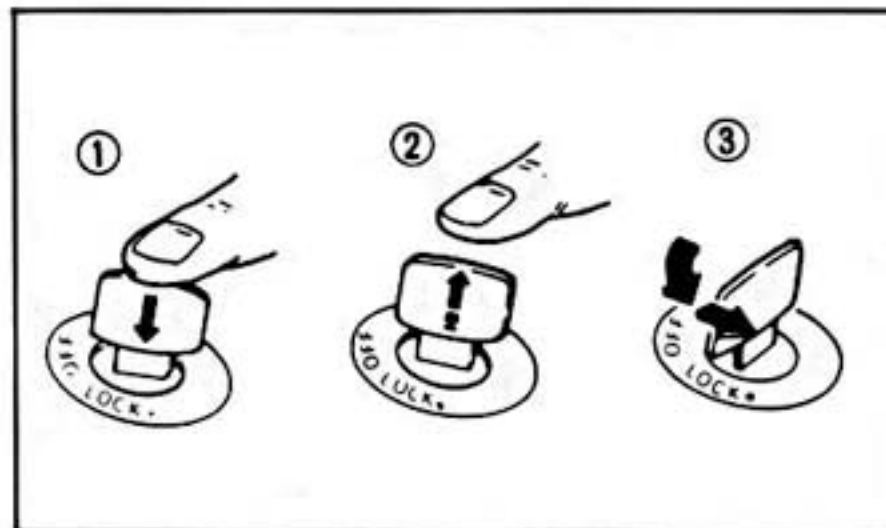
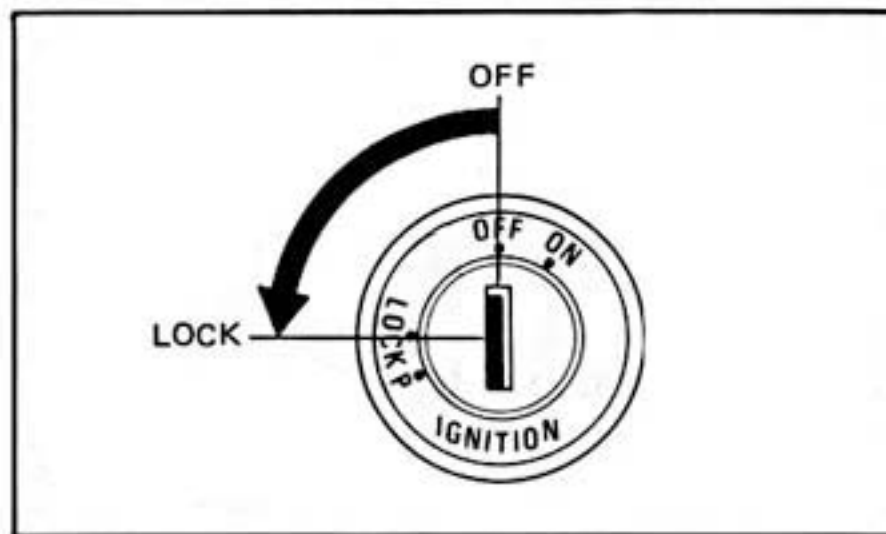

1. Push

2. Release

3. Turn

WARNING:

Never turn the key to "LOCK" when the motorcycle is moving.

Seat lock

To open the seat lock, turn the key as shown. To lock the seat, remove the key and install the seat in its original position.



Helmet holder

To open the helmet holder, insert the key in the lock and turn it as shown. To lock the helmet holder, replace the holder in its original position.

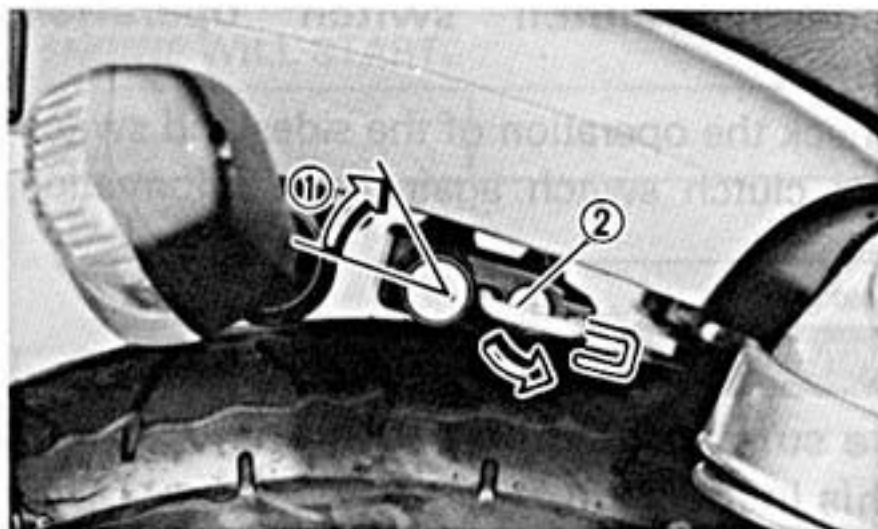

1. Open

2. Helmet holder

U-615

WARNING:

Never ride with a helmet in the helmet holder. It could interfere with rear wheel movement, causing loss of control and possibly an accident.

C-902

Rear shock absorber

The spring preload of the rear shock absorber can be adjusted to suit motorcycle's load (ex: optional accessories etc.) and riding condi-

tions. Refer to page 7-29 for proper adjustment procedures.

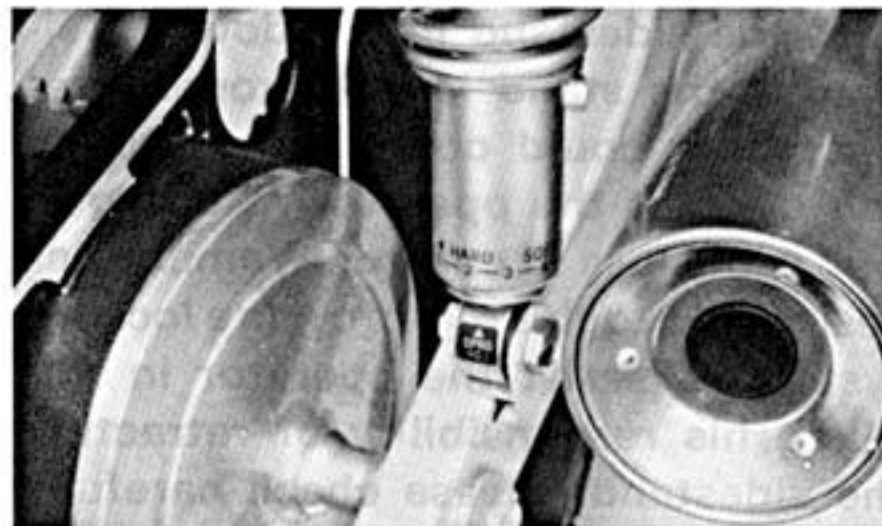

D-300

Sidestand

This model is equipped with an ignition circuit cut-off system. The motorcycle must not be ridden when the sidestand is down. The sidestand is located on the left side of the frame. (Refer to page 6-1 for an explanation of this system.)

WARNING:

This motorcycle must not be operated with the sidestand in the down position. If the stand is not properly retracted, it could contact the ground and distract the operator resulting in a possible loss of control. Yamaha has designed into this motorcycle a lockout system to assist the operator in fulfilling his responsibility of retracting the sidestand. Please check carefully the operating instructions listed below and if there is any indication of a malfunction, you must return the motorcycle to a Yamaha dealer or other qualified mechanic immediately for repair.

Sidestand/clutch switch operation check

Check the operation of the sidestand switch and clutch switch against the information below.

WARNING:

Be sure to use the centerstand during this inspection.

TURN MAIN SWITCH TO "ON" AND ENGINE STOP SWITCH TO "RUN".

TRANSMISSION IS IN GEAR AND SIDESTAND IS UP.

PULL IN CLUTCH LEVER AND PUSH STARTER SWITCH.

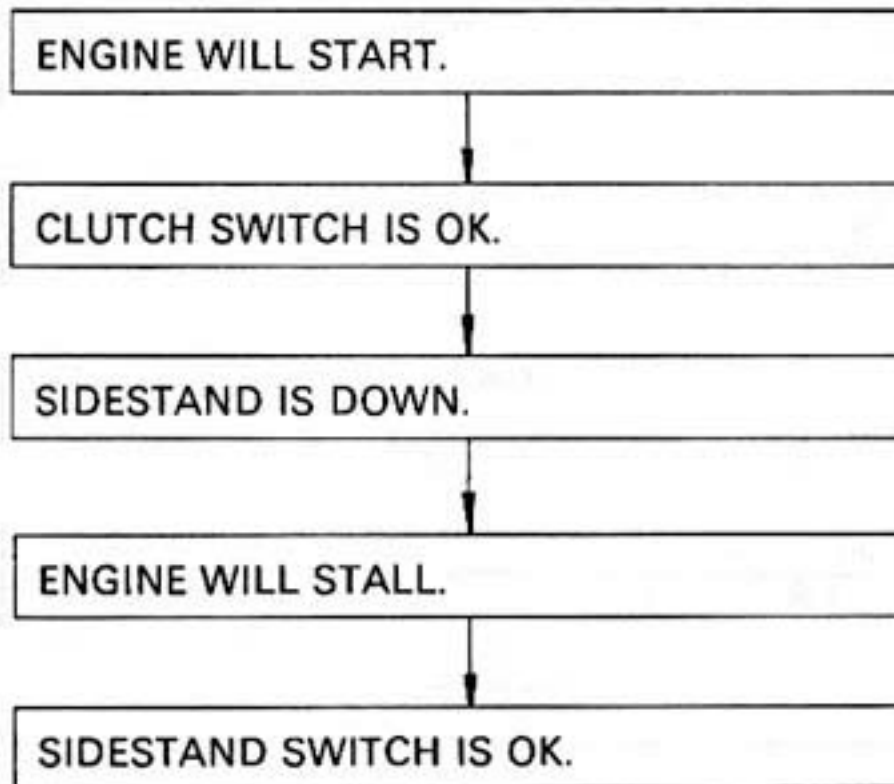

U-695

WARNING:

If improper operation is noted, consult a Yamaha dealer or other qualified mechanic immediately.

PRE-OPERATION CHECKS

Before using this motorcycle, check the following points:

| Item | Routine | Page |
|--------------------|---|--------------------|
| Front brake | Check operation, free play, fluid level and fluid leakage. Top-up with D.O.T. No.3 brake fluid if necessary. | 5-3 7-16 ~ 7-21 |
| Rear brake | Check operation, condition and free play. Adjust if necessary. | |
| Clutch | Check operation, condition and free play. | 7-21 |
| Engine oil | Check engine oil level, add oil if necessary. | 5-4, 7-11 ~ 7-14 |
| Drive chain | Check chain tension and condition. Adjust if necessary. | 5-5, 7-23 ~ 7-25 |
| Throttle | Check for smooth operation. Adjust if necessary. | 5-4, 7-26 |
| Battery | Check fluid level, top-up with distilled water if necessary. | 5-10, 7-31 ~ 7-33 |
| Lights/Signals | Check operation. | 5-10, 7-34 ~ 7-37 |
| Wheels/Tires | Check tire pressure, wear, damage. | 5-5 ~ 5-9 |
| Fittings/Fasteners | Check all chassis fittings and fasteners. Adjust if necessary. | 7-10 |

NOTE:

Pre-operation checks should be made each time the motorcycle is used. Such an inspection can be thoroughly accomplished in a very short time; and the added safety it assures is more than worth the time involved.

WARNING:

1. The engine, exhaust pipe(s), and muffler(s) will be very hot after the engine has been run. Be carefull not to touch them or to allow any clothing item to contact them during inspection or repair.
 2. If any item in the PRE-OPERATION CHECK is not working properly, have it inspected and repaired before operating the motorcycle.
-

Brakes (See page 7-16 for more detail)

1. Brake lever and brake pedal

Check for correct free play in the front brake lever and rear brake pedal. Make sure they are working properly. Check the brakes at low speed shortly after starting out. If the free play is incorrect, adjust it.

U-622

WARNING: _____

A soft, spongy feeling in the brake lever indicates a failure in the brake system. Do not operate the motorcycle until the failure in the brake system is corrected. Ask a Yamaha dealer or other qualified mechanic for immediate repairs. A soft, spongy feeling could indicate a hazardous condition in the brake system.

2. Brake fluid

Check the brake fluid level.
Add fluid if necessary.

Recommended brake fluid: DOT#3

3. Check the disc pads.

Refer to page 7-19.

4. Check the brake shoes.

Refer to page 7-19.

U-021

NOTE: _____

When this brake service is necessary, ask a Yamaha dealer or other qualified mechanic.

E-112

Brake fluid leakage (Front)

Apply the brake for a few minutes. Check to see if any brake fluid leaks out from the pipe joints or the master cylinder.

WARNING:

If brake fluid leakage is found, ask a Yamaha dealer or other qualified mechanic for immediate repairs. Such leakage could indicate a hazardous condition.

Clutch (See page 7-21 for more detail)

Check the free play in the clutch lever, and make sure the lever operates properly. If the free play is incorrect, adjust it.

Throttle grip (See page 7-26 for more detail)

Turn the throttle grip to see if it operates properly, and check the free play. Make sure the grip returns by spring force when released. Ask a Yamaha dealer or other qualified mechanic to make any necessary adjustments.

Engine oil (See page 7-11 for more detail)

Make sure the engine oil is at the specified level. Add oil as necessary.

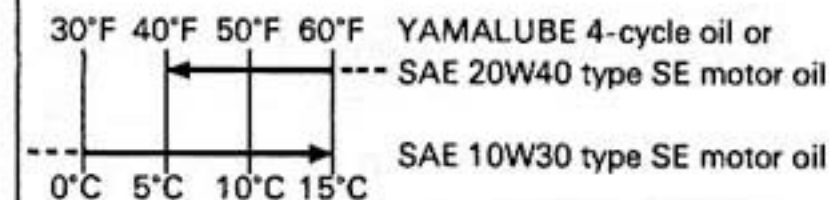
Recommended oil:**Oil quantity:****Total amount:**

2.9 L (2.5 Imp qt, 3.1 US qt)

Periodic oil change:

2.2 L (1.9 Imp qt, 2.3 US qt)

With oil filter replacement:

2.5 L (2.2 Imp qt, 2.6 US qt)

U-080

NOTE: _____
 Recommended engine oil classification; API Service "SE", "SF" type or equivalent (e.g. "SF-SE", "SF-SE-CC", "SF-SE-SD" etc.).

E-500

Chain (See page 7-25 for more detail)
 Check the general condition of the chain and check the chain slack before every ride. Lubricate and adjust the chain as necessary.

E-901

Tires

To ensure maximum performance, long service, and safe operation, note the following:

1. Tire air pressure
 Always check and adjust the tire pressure before operating the motorcycle.

U-675

WARNING: _____

Tire inflation pressure should be checked and adjusted when the temperature of the tire equals the ambient

air temperature. Tire inflation pressure must be adjusted according to total weight of cargo, rider, passenger, and accessories (fairing, saddlebags, etc. if approved for this model), and vehicle speed.

CE9-03

| | | |
|--|---|---|
| Basic weight: With oil and full fuel tank | 197 kg (434 lb) | |
| Maximum load* | 258 kg (569 lb) | |
| Cold tire pressure | Front | Rear |
| Up to 90 kg (198 lb) load* | 177 kPa (1.8 kg/cm ² , 26 psi) | 196 kPa (2.0 kg/cm ² , 28 psi) |
| 90 kg (198 lb) ~ 160 kg (353 lb) load* | 196 kPa (2.0 kg/cm ² , 28 psi) | 226 kPa (2.3 kg/cm ² , 32 psi) |
| 160 kg (353 lb) ~ Maximum load* | 196 kPa (2.0 kg/cm ² , 28 psi) | 245 kPa (2.5 kg/cm ² , 36 psi) |
| High speed riding | 196 kPa (2.0 kg/cm ² , 28 psi) | 226 kPa (2.3 kg/cm ² , 32 psi) |

*Load is the total weight of cargo, rider, passenger, and accessories.

WARNING:

Proper loading of your motorcycle is important for the handling, braking, and other performance and safety characteristics of your motorcycle. Do not carry loosely packed items that can shift. Securely pack your heaviest items close to the center of the motorcycle, and distribute the weight evenly from side to side. Properly adjust the suspension for your load, and check the condition and pressure of your tires. **NEVER OVERLOAD YOUR MOTORCYCLE.** Make sure the total weight of the cargo, rider, passenger, and accessories (fairing, saddlebags, etc. if approved for this model) does not exceed the maximum load of the motorcycle. Operation of an overloaded motorcycle could cause tire damage, an accident, or even injury.

2. Tire inspection

Always check the tires before operating the motorcycle. If a tire tread shows crosswise lines (minimum tread depth), if the tire has a nail or glass fragments in it, or if the side wall is cracked, contact a Yamaha dealer or other qualified mechanic immediately and have him replace the tire.

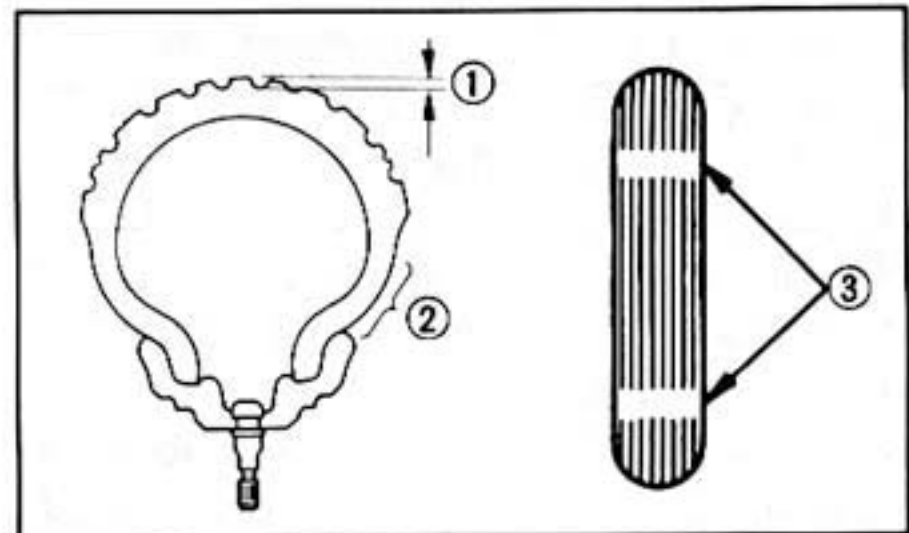

1. Tread depth 2. Side wall 3. Wear indicator

CE9-02

FRONT:

| Manufacture | Size | Type |
|-------------|---------------|-------|
| Bridgestone | 110/90-16 59H | G527 |
| Dunlop | 110/90-16 59H | K355F |

REAR:

| Manufacture | Size | Type |
|-------------|---------------|------|
| Bridgestone | 130/90-16 67H | G528 |
| Dunlop | 130/90-16 67H | K355 |

| | |
|---|------------------|
| Minimum tire tread depth (front and rear) | 1.0 mm (0.04 in) |
|---|------------------|

U-680

WARNING:

It is dangerous to ride with a worn-out tire. When a tire tread begins to show lines. Have a Yamaha dealer or other qualified mechanic replace the tire immediately. Brakes, tires, and related wheel parts replacement should be left to a Yamaha Service Technician or other qualified mechanic.

E-937

Tubeless tires and cast wheels

This motorcycle is equipped with cast wheels designed for either tube or tubeless tires. Tubeless tires are installed as standard equipment.

U-686

WARNING:

Do not attempt to use tubeless tires on a wheel designed for use only with tube-type tires. Tire failure and personal injury may result from sudden deflation.

Tube-type Wheel

→ Tube-type Tires only

Tubeless-type Wheel

→ Tube-type or Tubeless tires

U-687

WARNING:

When using tube-type tires, be sure to install the proper tube also.

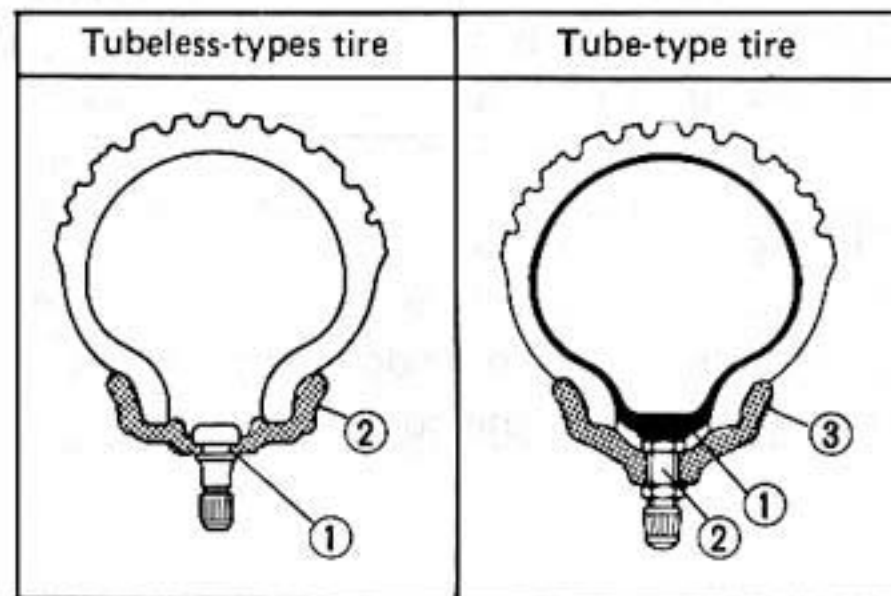
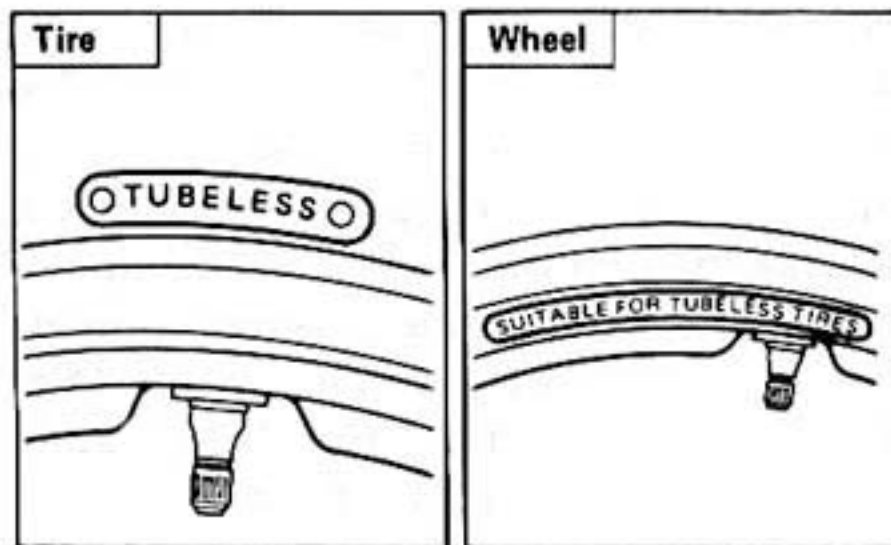

1. Air valve
2. Cast wheel
(Tubeless wheel)

1. Tube
2. Air valve
3. Cast wheel

To ensure maximum performance, long service, and safe operation, note the following:

1. Always inspect the wheels before a ride. Check for cracks, bends, or warpage of the wheels. If any abnormal condition exists in a wheel, consult a Yamaha dealer or other qualified mechanic. Do not attempt even small repairs to the wheel. If a wheel is deformed or cracked, it must be replaced.
2. Tires and wheels should be balanced whenever either one is changed or replaced. Failure to have a wheel balanced can result in poor performance, adverse handling characteristics, and shortened tire life.
3. After installing a tire, ride conservatively to allow the tire to seat itself on the rim properly. Failure to allow proper seating may cause tire failure, resulting in damage to the motorcycle and injury to the rider.

4. After repairing or replacing a tire, check to be sure the valve stem lock nut is securely fastened. If not, torque it as specified.

Tightening torque:
1.5 Nm (0.15 m·kg, 1.1 ft·lb)

E-939

Accessories or replacement parts

U-697

WARNING:

This motorcycle is not designed to pull a trailer or to be attached to a sidecar. The accessories or replacement parts you choose for your motorcycle should be designed specifically for it, and they must be securely mounted to maintain the inherent stability of the original design. Genuine Yamaha Parts and Accessories are designed and tested to be compatible with your motorcy-

cle. Please consider Genuine Yamaha Parts and Accessories before making an accessory purchase. Use of non-Yamaha-approved parts or accessories may cause loss of handling stability and riding safety. Since Yamaha cannot control the quality of parts or accessories manufactured by other companies, Yamaha cannot be held liable for any consequence caused by the use of items which have not been approved by Yamaha.

E-850

Fittings/Fasteners

Always check the tightness of chassis fittings and fasteners before a ride. Use the chart on page 7-10 to find the correct torque.

E-700

Lights and signals

Check the headlight, flasher lights, taillight, brake light, meter lights, and all the indicator lights to make sure they are in working condition.

E-707

Switches

Check the operation of the headlight switch, turn switch, brake light switch, horn switch, starter switch, main switch, etc.

E-705

Battery (See page 7-31 for more detail)

Check the fluid level and top-up if necessary. Use only distilled water if refilling is necessary.

E-800

Fuel

Make sure there is sufficient fuel in the tank.

U-610

WARNING:

Do not overfill the fuel tank. Avoid spilling fuel on the hot engine. Do not fill the fuel tank above the bottom of the filler tube as shown in the illustration or it may overflow when the fuel heats up later and expands.

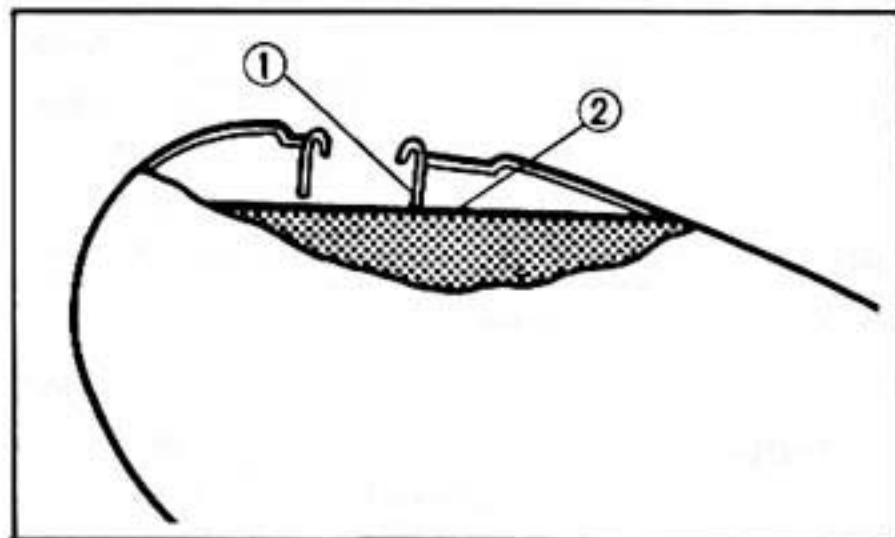

1. Filler tube

2. Fuel level

Recommended fuel: Regular gasoline

Fuel tank capacity:

Total:

1.2 L (2.6 Imp gal, 3.2 US gal)

Reserve:

2.5 L (0.5 Imp gal, 0.7 US gal)

Fuel tank breather hose

This model is equipped with the fuel tank breather hose. Before using this motorcycle be sure to check the following:

1. Check hose connection.
2. Check hose for cracks or damage. Replace if damaged.
3. Make sure the bottom hose is not blocked. Clean it if necessary.

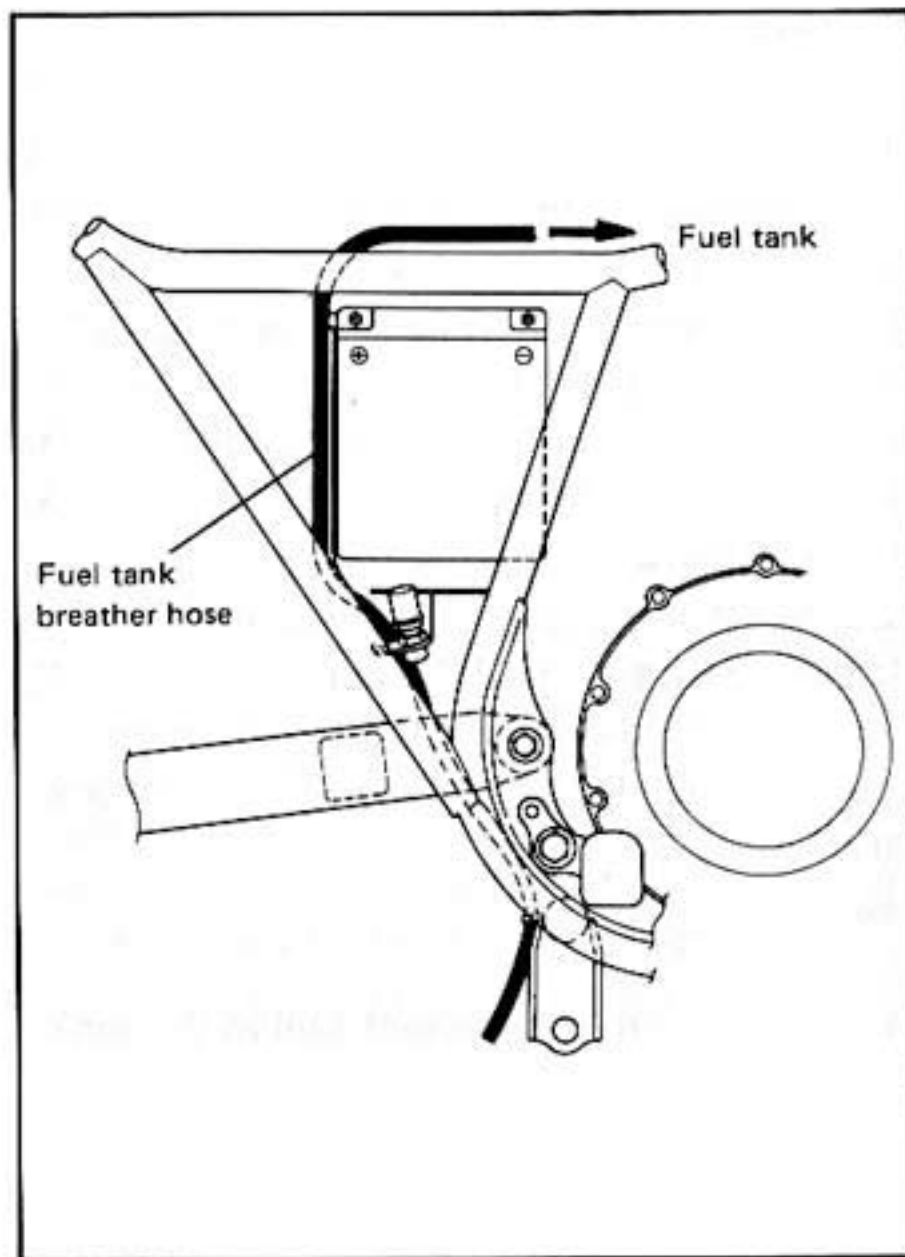

OPERATION AND IMPORTANT RIDING POINTS

U-627

WARNING:

Before riding this motorcycle, become thoroughly familiar with all operating controls and their function. Consult a Yamaha dealer or other qualified mechanic regarding any control or function that you do not thoroughly understand.

U-311

CAUTION:

1. Be careful where you store personal items on the motorcycle. Avoid blocking the air cleaner intake or performance will suffer.
2. Be careful not to put anything near the battery and its terminals.

Electrical failure and acid corrosion may result.

U-628

WARNING:

1. Never start your engine or let it run for any length of time in a closed area. The exhaust fumes are poisonous and can cause loss of consciousness and death within a short time. Always operate your motorcycle in an area with adequate ventilation.
2. Before starting out, always be sure the sidestand is up. Failure to retract the sidestand completely can result in a serious accident when you try to turn a corner.

Starting and warming up a cold engine

U-028

NOTE: _____

This motorcycle is equipped with a starting and an ignition circuit cut-off switch.

1. The engine can be started only under the following conditions:
 - a. The transmission is in neutral.
 - b. The sidestand is up, the transmission is in gear, and the clutch is disengaged.
2. The motorcycle must not be ridden when the sidestand is down.

U-692

WARNING: _____

Before going through the following steps, check the function of the sidestand switch and clutch switch. (Refer to page 4-12.)

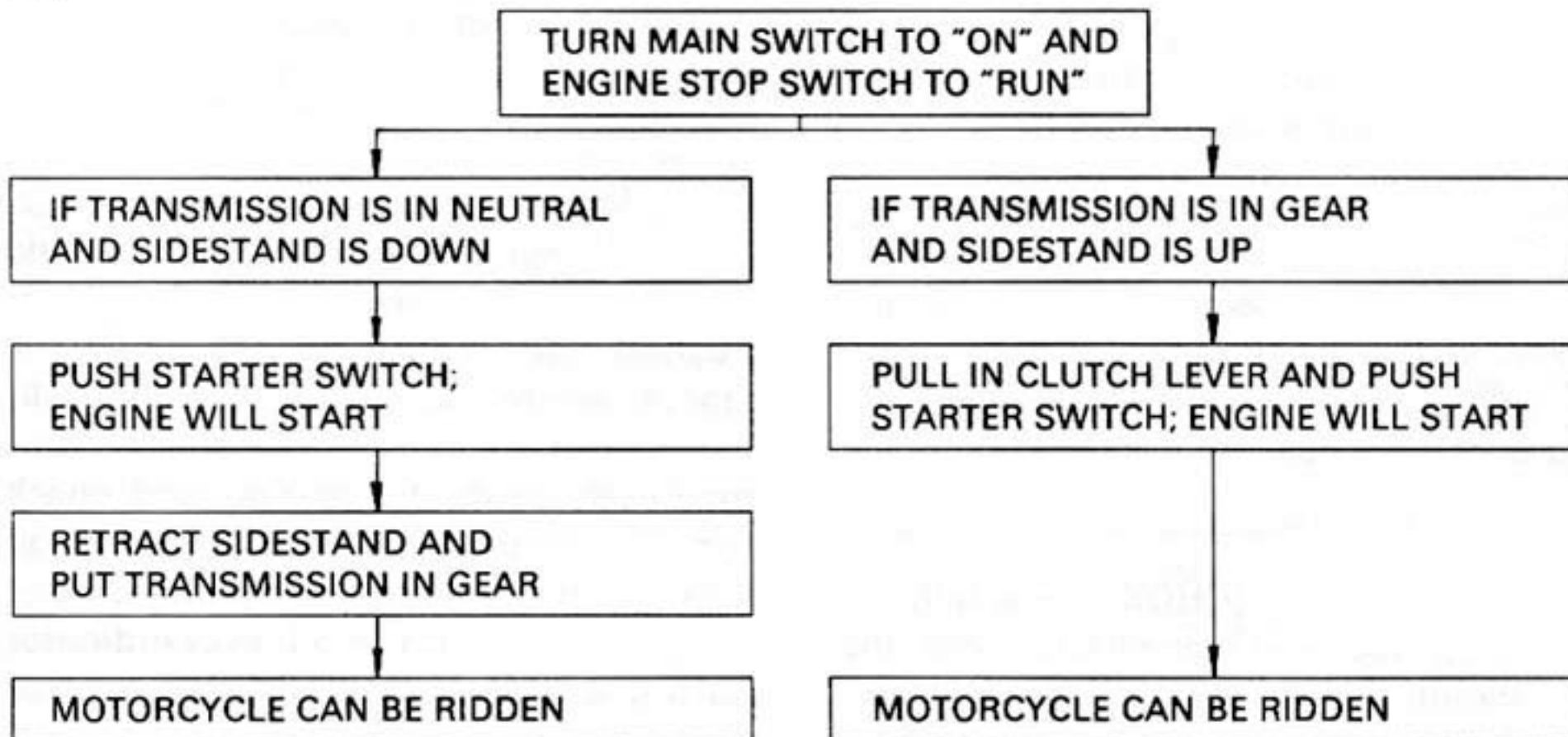

1. Turn the fuel cock to "ON."
2. Turn the ignition key to "ON" and the engine stop switch to "RUN."
3. Shift transmission into neutral.

U-029

NOTE: _____

When the transmission is in neutral, the neutral indicator light (green) should be on. If the light does not come on, ask a Yamaha dealer or other qualified mechanic to inspect it.

4. Turn the starter (CHOKE) lever fully toward you and completely close the throttle grip.
5. Start the engine by pushing the starter switch.

U-025

NOTE: _____

If the engine fails to start, release the starter switch, wait a few seconds, then try again. Each attempt should be as short as possible to preserve the battery. Do not crank the

engine more than 10 seconds on any one attempt.

U-313

CAUTION: _____

The oil level indicator light should come on when the starter switch is pushed and should go off when the starter switch is released. If the indicator light flickers or remains on, immediately stop the engine and check for the engine oil level and for oil leakage. If necessary, replenish oil and check to see that the oil level indicator light goes off. If the light does not go off even with sufficient oil in the crankcase or the light does not come on when pushing the starter switch, consult a Yamaha dealer or other qualified mechanic.

6. After starting the engine, turn back the starter lever. The starter operation periods differ with the ambient temperature, so refer to the following notes.

U-031

NOTE: _____
The engine is warm when it responds normally to the throttle with the starter turned off. To avoid the possibility of excessive exhaust emissions, never leave the starter circuit on longer than necessary. The length of time the starter is needed depends upon the ambient temperature. Warm ambient temperatures (above 10°C ~ 50°F) require about 7 seconds of starter use. Cold ambient temperatures (below 10°C ~ 50°F) require about 35 seconds with the starter fully open, then about 2.5 minutes with the starter in the half-open position. To get maximum engine life, always warm up the engine before starting off. Never accelerate hard with a cold engine!

F-108

Starting a warm engine

The starter (CHOKE) is not required when the engine is warm.

U-314

CAUTION: _____

See "Break-in section" prior to operating the motorcycle for the first time.

F-200

Shifting

The transmission lets you control the amount of power you have available at a given speed for starting, accelerating, climbing hills, etc. The use of the change pedal is shown in the illustration. (Page 4-6)

To shift into NEUTRAL, depress the change pedal repeatedly until it reaches the end of its travel (you will feel a stop when you are in first gear) then raise the pedal slightly.

To start out and accelerate:

1. Pull the clutch lever to disengage the clutch.
2. Shift into FIRST gear. The green neutral indicator light should go out.
3. Open the throttle gradually, and at the same time, release the clutch lever slowly.
4. At the recommended shift point in the table below, close the throttle, and at the same time, quickly pull in the clutch lever.
5. Shift into SECOND gear. (Be careful not to shift into neutral.)
6. Open the throttle part way and gradually release the clutch lever.
7. Follow the same procedure when shifting to the next higher gear. Always shift gears at the recommended shift points.

To decelerate:

1. Apply front and/or rear brakes to slow the motorcycle.
2. When the motorcycle reaches 20 km/h (12.5 mi/h), shift into first gear. Any time the engine is about to stall or runs very roughly, pull in the clutch and use the brakes to stop.
3. When the motorcycle is almost completely stopped, shift into neutral. The green neutral indicator light should come on.

Recommended shift point

| | Acceleration Shift point km/h (mi/h) | Deceleration Shift point km/h (mi/h) |
|-----------|--|--|
| 1st → 2nd | 16 (9.9) | 20 (12.5) |
| 2nd → 3rd | 24 (14.9) | 20 (12.5) |
| 3rd → 4th | 32 (19.9) | 20 (12.5) |
| 4th → 5th | 40 (24.9) | 20 (12.5) |
| 5th → 6th | 48 (29.9) | 20 (12.5) |

Engine break-in

There is never a more important period in the life of your motorcycle than the period between zero and 1,000 km (600 mi). For this reason we ask that you carefully read the following material. Because the engine is brand new, you must not put an excessive load on it for the first 1,000 km (600 mi). The various parts in the engine wear and polish themselves to the correct operating clearances. During this period, prolonged full throttle operation or any condition which might result in excessive heating of the engine, must be avoided.

1. 0 ~ 150 km (0 ~ 90 mi):

Avoid operation above 5,000 r/min. Stop the engine and let it cool for 5 to 10 minutes after every hour of operation. Vary the speed of the motorcycle from time to time. Do not operate it at one set throttle position.

2. 150 ~ 500 km (90 ~ 300 mi):
Avoid prolonged operation above 6,500 r/min. Rev the motorcycle freely through the gears, but do not use full throttle at any time.
3. 500 ~ 1,000 km (300 ~ 600 mi):
Avoid prolonged full throttle operation. Avoid cruising speeds in excess of 8,000 r/min.

CAUTION:

After 1,000 km (600 mi) of operation, be sure to replace the engine oil and oil filter element.

4. 1,000 km (600 mi) and beyond:
Full throttle can be used.

CAUTION:

Never let engine speeds enter the red zone.

CAUTION:

If any engine trouble should occur during the break-in period, consult a Yamaha dealer or other qualified mechanic immediately.

Parking

When parking the motorcycle, stop the engine and remove the ignition key.

WARNING:

The muffler and exhaust pipe are hot. Park the motorcycle in a place where pedestrians or children are not likely to touch the motorcycle.

Do not park the motorcycle on a slope or soft ground; the motorcycle may overturn.

PERIODIC MAINTENANCE AND MINOR REPAIR

H-001

Periodic inspection, adjustment, and lubrication will keep your motorcycle in the safest and most efficient condition possible. Safety is an obligation of the motorcycle owner.

The most important points of motorcycle inspection, adjustment, and lubrication are explained in the following pages.

“Maintenance, replacement, or repair of the emission control devices and systems may be performed by any repair establishment or individual using any part which is certified (if applicable).”

U-631

WARNING:

If you are not familiar with motorcycle service, this work should be done by a

Yamaha dealer or other qualified mechanic.

H-003

Periodic Maintenance

PROPER PERIODIC MAINTENANCE OF YOUR MOTORCYCLE IS IMPORTANT TO ITS GIVING YOU LONG, PLEASURABLE SERVICE: ESPECIALLY IMPORTANT ARE THE MAINTENANCE SERVICES RELATED TO EMISSIONS CONTROL. THESE CONTROLS NOT ONLY FUNCTION TO ENSURE CLEANER AIR BUT ARE ALSO VITAL TO PROPER ENGINE OPERATION AND MAXIMUM PERFORMANCE. IN THE FOLLOWING TABLES OF PERIODIC MAINTENANCE, THE SERVICES RELATED TO EMISSIONS CONTROL ARE GROUPED SEPARATELY. THESE SERVICES REQUIRE SPECIALIZED DATA, KNOWLEDGE, AND EQUIPMENT. YAMAHA DEALERS ARE TRAINED AND EQUIPPED TO PERFORM THESE PARTICULAR SERVICES.

Tool kit

The service information included in this manual is intended to provide you, the owner, with the necessary information for completing some of your own preventive maintenance and minor repairs. The tools provided in the owner's tool kit are sufficient for most of these purposes; however a torque wrench is also necessary to properly tighten nuts and bolts.



1. Tool kit

NOTE: _____

If you do not have a torque wrench available during a service operation requiring one, take your motorcycle to a Yamaha dealer or other qualified mechanic to check the torque settings and adjust them as necessary.

WARNING: _____

Modifications to this motorcycle not approved by Yamaha may cause loss of performance, excessive emissions, and render it unsafe for use. Consult a Yamaha dealer or other qualified mechanic before attempting any changes.

PERIODIC MAINTENANCE EMISSION CONTROL SYSTEM

| No. | Item | Remarks | Initial | Odometer readings | | | | |
|-----|------------------------------|--|---------------------------------------|---|---|---|--|---|
| | | | 1,000 km or 1 month (600 mi) | **1 7,000 km or 7 months (4,400 mi) | **2 13,000 km or 13 months (8,200 mi) | 19,000 km or 19 months (12,000 mi) | **3 25,000 km or 25 months (15,800 mi) | 31,000 km or 31 months (19,600 mi) |
| 1* | Cam chain | Adjust chain tension. | *○ | ○ | ○ | ○ | ○ | ○ |
| 2* | Valve clearance | Check and adjust valve clearance when engine is cold. | | | | | ○ | |
| 3 | Spark plug | Check condition. Adjust gap and clean. Replace at 13,000 km (or 13 months) and thereafter every 12,000km (or 12 months). | | ○ | Replace | ○ | Replace | ○ |
| 4* | Crankcase ventilation system | Check ventilation hose for cracks or damage. Replace if necessary. | | ○ | ○ | ○ | ○ | ○ |
| 5* | Fuel line | Check fuel hose and vacuum pipe for cracks or damage. Replace if necessary. | | ○ | ○ | ○ | ○ | ○ |
| 6* | Exhaust system | Check for leakage. Retighten if necessary. Replace gasket(s) if necessary. | | ○ | ○ | ○ | ○ | ○ |
| 7* | Carburetor synchronization | Adjust synchronization of carburetors. | *○ | ○ | ○ | ○ | ○ | ○ |
| 8* | Idle speed | Check and adjust engine idle speed. Adjust cable free play. | | ○ | ○ | ○ | ○ | ○ |

* It is recommended that these items be serviced by a Yamaha dealer or other qualified mechanic.

NOTE:

For father odometer reading, repeat the above maintenance at the period established; **1: Every 6,000 km (3,800 mi), **2: Every 12,000 km (7,600 mi), and **3: Every 30,000 km (19,000 mi) intervals.

Spark plug inspection

The spark plug is an important engine component and is easy to inspect. The condition of the spark plug can indicate something of the condition of the engine.

Normally, all spark plugs from the same engine should have the same color on the white porcelain insulator around the center electrode. The ideal color at this point is a medium to light tan color for a motorcycle that is being ridden normally. If one spark plug shows a distinctly different color, there could be something wrong with the engine.

Do not attempt to diagnose such problems yourself. Instead, take the motorcycle to a Yamaha dealer or other qualified mechanic. You should periodically remove and inspect the spark plug because heat and deposits will cause any spark plug to slowly break down and erode. If electrode erosion becomes excessive, or if carbon and other deposits are excessive, you should replace the spark plug with a proper type plug.

Standard spark plug:
D8EA (NGK) or
X24ESU (NIPPONDENSO)

Before installing any spark plug, measure the electrode gap with a wire thickness gauge; adjust the gap to specification as necessary.

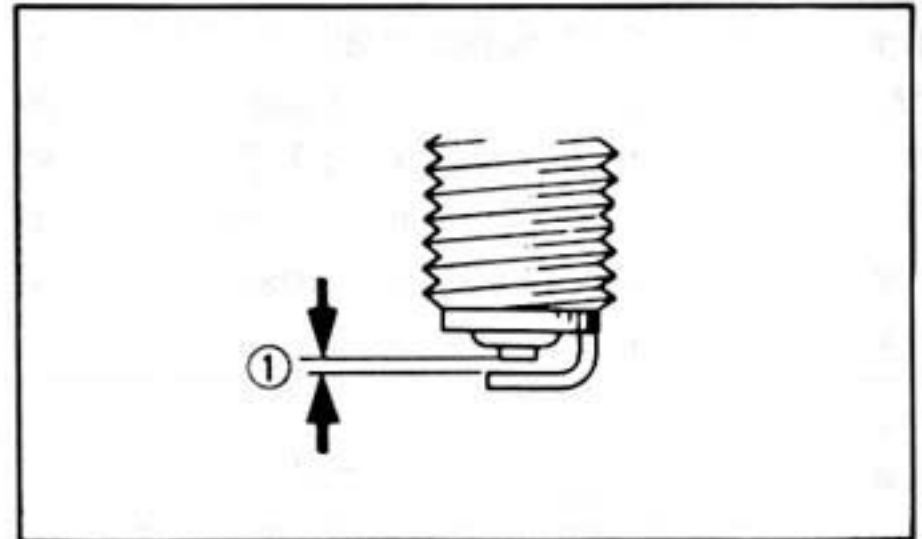

1. Spark plug gap

Spark plug gap:
0.6 ~ 0.7 mm (0.024 ~ 0.028 in)

When installing the plug, always clean the gasket surface and use a new gasket. Wipe off any grime from the threads, and torque the spark plug properly.

Spark plug torque:
17.5 Nm (1.75 m·kg, 12.5 ft·lb)

U-038

NOTE:

If a torque wrench is not available when you are installing a spark plug, a good estimate of the correct torque is 1/4 to 1/2 turns past finger tight. Have the spark plug torqued to the correct value as soon as possible with a torque wrench.

H-904

Canister (for California only)

This model is equipped with a canister to prevent the discharging of fuel vapor into the atmosphere. Before using this motorcycle be sure to check the following:

1. Check each hose connection.

2. Check each hose and canister for cracks or damage. Replace if damaged.
3. Make sure the bottom (vent.) hose is not blocked. Clean it if necessary.

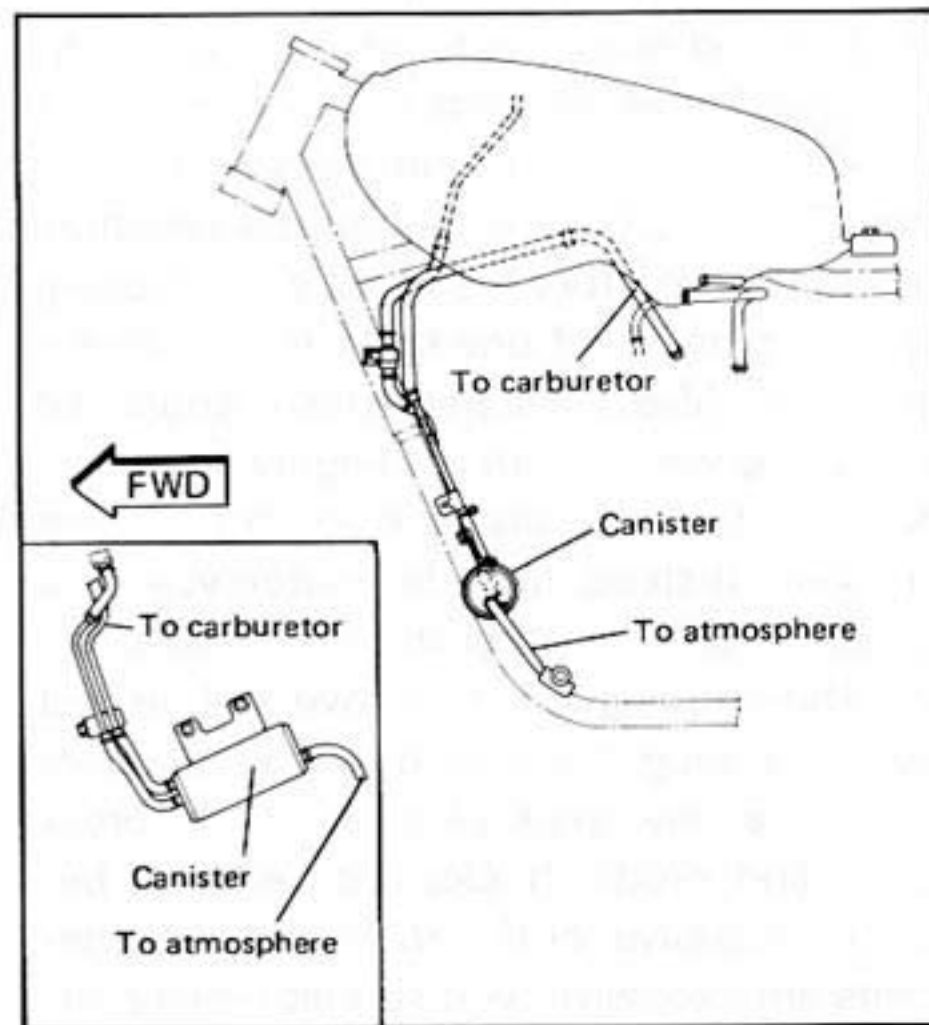

GENERAL MAINTENANCE/LUBRICATION

| No. | Item | Remarks | type | Initial | Odometer reading | | | | |
|-----|-------------------------|--|--|---------------------------------------|---|---|---|--|---|
| | | | | 1,000 km or 1 month (600 mi) | **1 7,000 km or 7 months (4,400 mi) | **2 13,000 km or 13 months (8,200 mi) | 19,000 km or 19 months (12,000 mi) | **3 25,000 km or 25 months (15,800 mi) | 31,000 km or 31 months (19,600 mi) |
| 1 | Engine oil | Warm-up engine before draining | *1) Yamalube 4-cycle oil or SAE 20W40 type "SE" motor oil *2) SAE 10W30 type "SE" motor oil | ○ | ○ | ○ | ○ | ○ | ○ |
| 2 | Oil filter | Replace | - | ○ | | ○ | | ○ | |
| 3* | Air filter | Clean with compressed air. Replace if necessary. | - | | ○ | ○ | ○ | ○ | ○ |
| 4* | Brake system | Adjust free play. Replace pads if necessary. (Front) Replace shoes if necessary. (rear) | - | ○ | ○ | ○ | ○ | ○ | ○ |
| 5* | Clutch | Adjust free play. | - | ○ | ○ | ○ | ○ | ○ | ○ |
| 6 | Drive chain | Check chain condition. Adjust and lubricate chain thoroughly. | SAE 30W-50W motor oil. | Every 500 km (300 mi) | | | | | |
| 7 | Control and meter cable | Apply chain lube thoroughly. | Yamaha chain and cable lube or SAE 10W30 motor oil | ○ | ○ | ○ | ○ | ○ | ○ |

| No. | Item | Remarks | type | Initial | Odometer reading | | | | |
|-----|------------------------------------|---|---|---------------------------------------|---|---|---|--|---|
| | | | | 1,000 km or 1 month (600 mi) | **1 7,000 km or 7 months (4,400 mi) | **2 13,000 km or 13 months (8,200 mi) | 19,000 km or 19 months (12,000 mi) | **3 25,000 km or 25 months (15,800 mi) | 31,000 km or 31 months (19,600 mi) |
| 8* | Rear arm pivot bearing | Check bearing assembly for looseness. Moderately repack every 24,000 km (15,200 mi). | Midium weight wheel bearing grease. | | | | | Repack | |
| 9 | Brake/Clutch lever pivot shaft | Apply chain lube lightly | Yamaha chain and cable lube or SAE 10W30 motor oil. | | ○ | ○ | ○ | ○ | ○ |
| 10 | Brake pedal and change pedal shaft | Lubricate. Apply chain lube lightly. | Yamaha chain and cable lube or SAE 10W30 motor oil. | | ○ | ○ | ○ | ○ | ○ |
| 11* | Center/Side stand pivots | Check operation and lubricate. Apply chain lube lightly. | Yamaha chain and cable lube or SAE 10W30 motor oil. | | ○ | ○ | ○ | ○ | ○ |
| 12* | Front fork oil | Check operation and leakage. | - | | ○ | ○ | ○ | ○ | ○ |
| 13* | Steering bearings | Check bearings assembly for looseness. Moderately repack every 24,000 km (15,000 mi). | Medium weight wheel bearing grease. | | ○ | ○ | ○ | Repack | ○ |

| No. | Item | Remarks | type | Initial | Odometer reading | | | | |
|-----|------------------|--|------|---------------------------------------|---|---|---|--|---|
| | | | | 1,000 km or 1 month (600 mi) | **1 7,000 km or 7 months (4,400 mi) | **2 13,000 km or 13 months (8,200 mi) | 19,000 km or 19 months (12,000 mi) | **3 25,000 km or 25 months (15,800 mi) | 31,000 km or 31 months (19,600 mi) |
| 14* | Wheel bearings | Check bearings for smooth rotation. | - | | ○ | ○ | ○ | ○ | ○ |
| 15 | Battery | Check specific gravity and breather pipe for proper operation. | - | | ○ | ○ | ○ | ○ | ○ |
| 16* | A.C. Generator | Replace genetor brushes. | - | | | ○ | | ○ | |
| 17* | Sidestand switch | Check and clean or replace if necessary. | - | ○ | ○ | ○ | ○ | ○ | ○ |

*1) If ambient temperature does not go below 5, C.

*2) If ambient temperature does not go below 15, C.

* It is recommended that these items be serviced by a Yamaha dealer or other qualified mechanic.

NOTE:

For father odometer reading, repeat the above maintenance at the period established, **1: Every 6,000 km (3,800 im), **2: Every 12,000 km (7,600 mi) and **3: Every 24,000 km (15,200 mi) intervals.

Torque specifications

(For a more complete list, refer to the Service Manual for this model.)

Use a torque wrench to tighten these items. It is recommended that these items be checked occasionally, especially before a long trip.

Always check the tightness of these items whenever they are loosened for any reason.

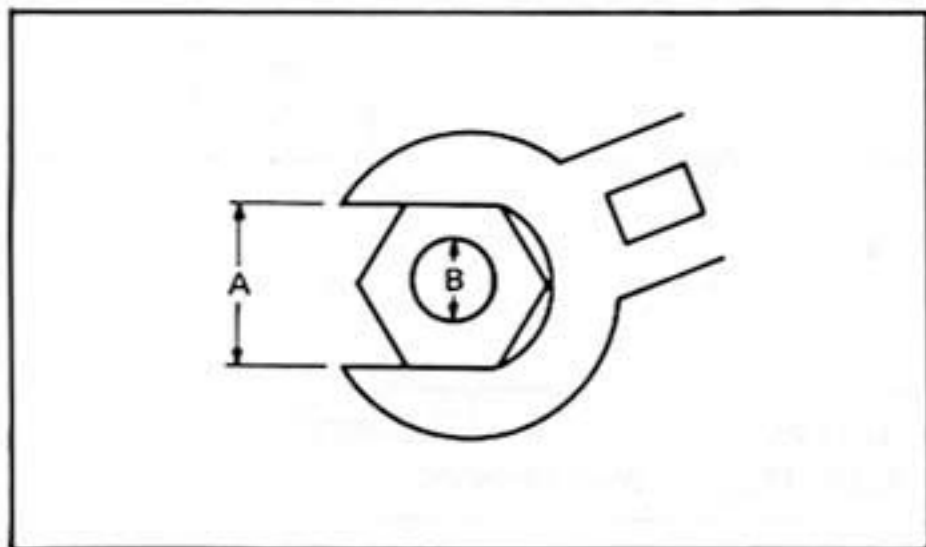

| A (Nut) | B (Bolt) | General torque specifications | | |
|------------|-------------|-------------------------------|------|-------|
| | | Nm | m·kg | ft·lb |
| 10 mm | 6 mm | 6 | 0.6 | 4.3 |
| 12 mm | 8 mm | 15 | 1.5 | 11 |
| 14 mm | 10 mm | 30 | 3.0 | 22 |
| 17 mm | 12 mm | 55 | 5.5 | 40 |
| 19 mm | 14 mm | 85 | 8.5 | 61 |
| 22 mm | 16 mm | 130 | 13.0 | 94 |

| Item | Torque | | |
|-----------------------|--------|------|-------|
| | Nm | m·kg | ft·lb |
| Spark plug | 17.5 | 1.75 | 12.5 |
| Engine drain plug | 43 | 4.3 | 31 |
| Oil filter bolt | 15 | 1.5 | 11 |
| Front fork cap bolt | 23 | 2.3 | 17 |
| Front fork pinch bolt | 23 | 2.3 | 17 |
| Front axle pinch bolt | 20 | 2.0 | 14 |
| Front axle | 105 | 10.5 | 75 |
| Rear wheel axle | 105 | 10.5 | 75 |

Engine oil

1. Oil level measurement
 - a. Place the motorcycle on the centerstand. Warm up the engine for several minutes.

U-039

NOTE:

Be sure the motorcycle is positioned straight up when checking the oil level; a slight tilt toward the side can produce false readings.

- b. With the engine stopped, check the oil level through the level window located at the lower part of the right side crankcase cover.

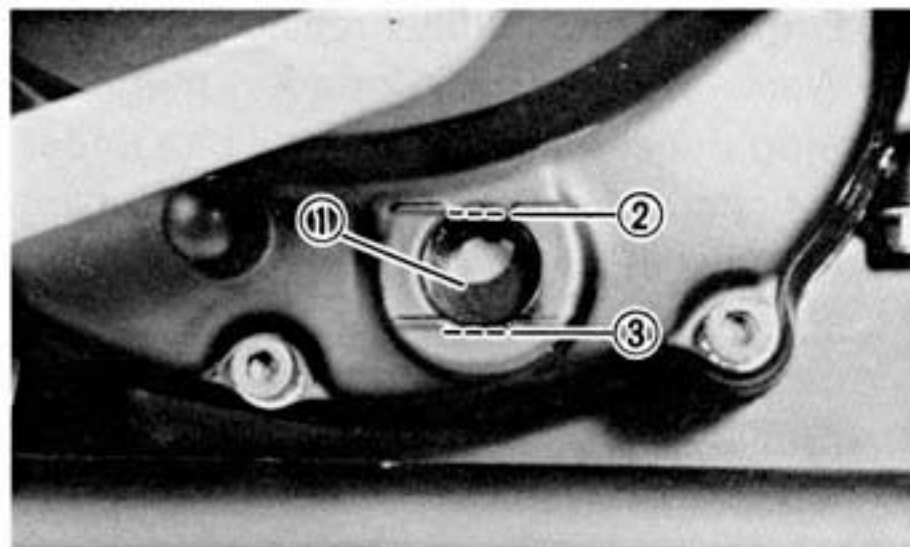

1. Level window
2. Maximum mark
3. Minimum mark

U-040

NOTE:

Wait a few minutes until the oil level settles before checking.

- c. The oil level should be between maximum and minimum marks. If the level is low, add sufficient oil to raise it to the proper level.

2. Engine oil and oil filter replacement
 - a. Warm-up the engine for a few minutes.
 - b. Stop the engine. Place an oil pan under the engine, and remove the oil filler cap.
 - c. Remove the drain plug and drain the oil.

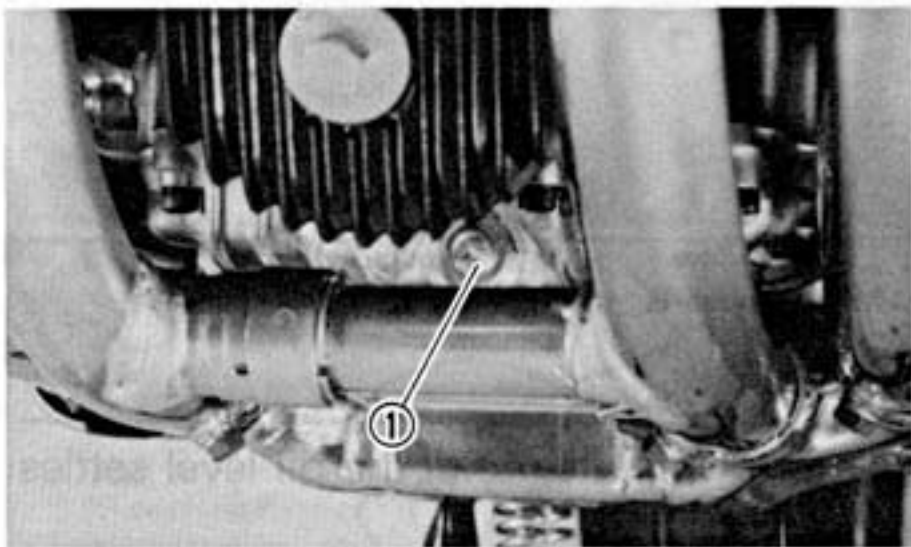

1. Drain plug

- d. Remove the oil filter bolt and filter element.

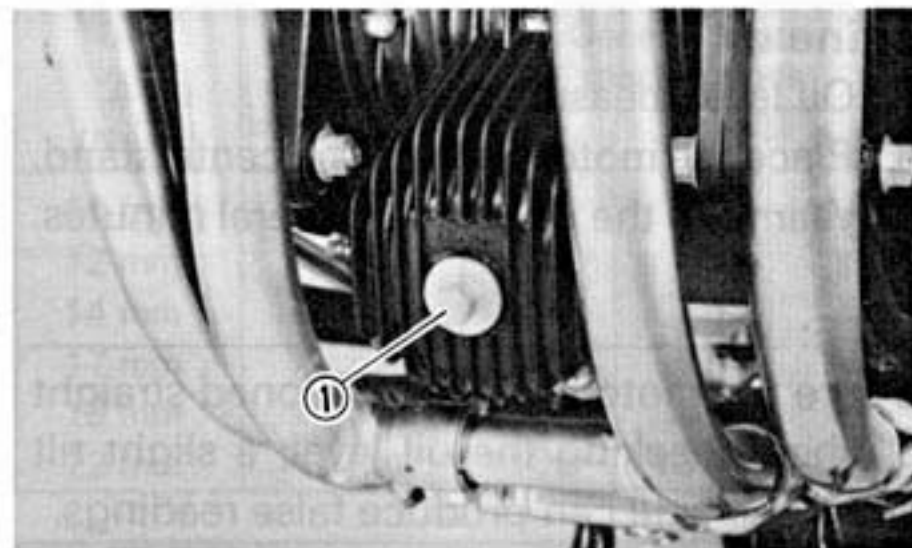

1. Oil filter bolt

- e. Reinstall the drain plug (make sure it is tight).

Drain plug torque:
43 Nm (4.3 m·kg, 31 ft·lb)

- f. Install the new oil filter element, new O-ring, and the filter cover; tighten the oil filter bolt.

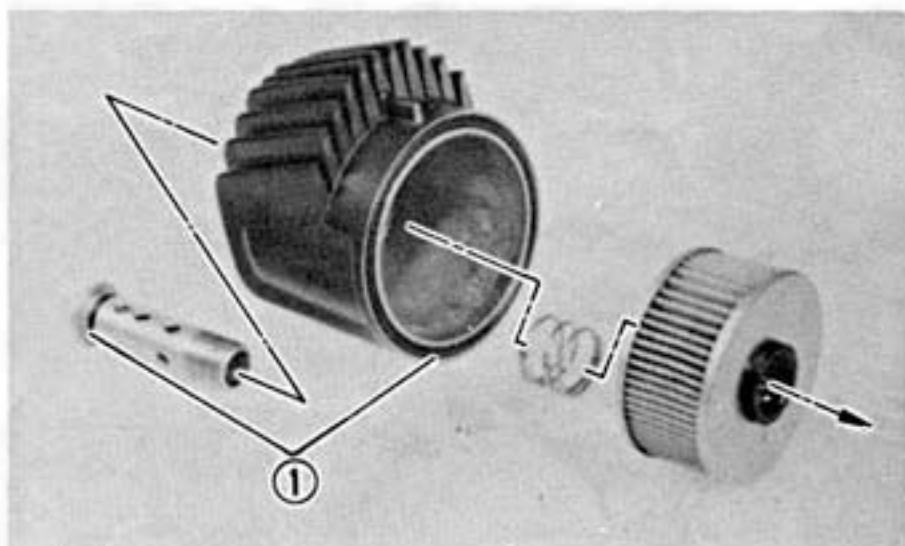

1. O-ring

Oil filter bolt:
15 Nm (1.5 m·kg, 11 ft·lb)

U-041

NOTE:

Make sure the O-ring is positioned properly.

g. Add oil through the oil filler hole.

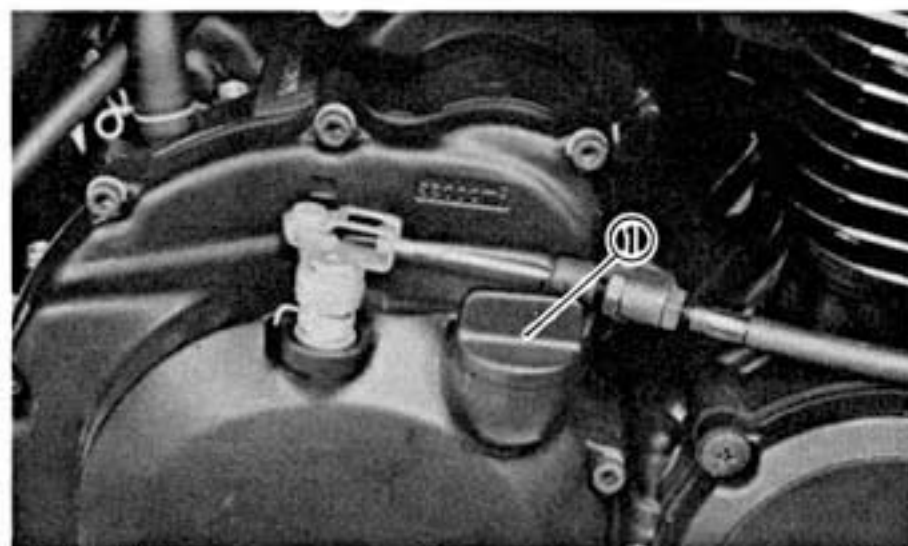

1. Oil filler cap

Periodic oil change:
2.2 L (1.5 Imp qt, 2.3 US qt)
With oil filter replacement:
2.5 L (2.2 Imp qt, 2.6 US qt)
Recommended oil: See page 5-4.

U-323

CAUTION:

Do not add any chemical additives.
Engine oil also lubricates the clutch and
additives could cause clutch slippage.

CAUTION:

Be sure no foreign material enters the crankcase.

- h. After replacement of engine oil and/or oil filter, be sure to check for any oil leakage. The oil level indicator should go off after the oil is filled.

CAUTION:

If the indicator light flickers or remains on, immediately stop the engine and consult a Yamaha dealer or other qualified mechanic.

Air filter

1. Remove the left side cover.

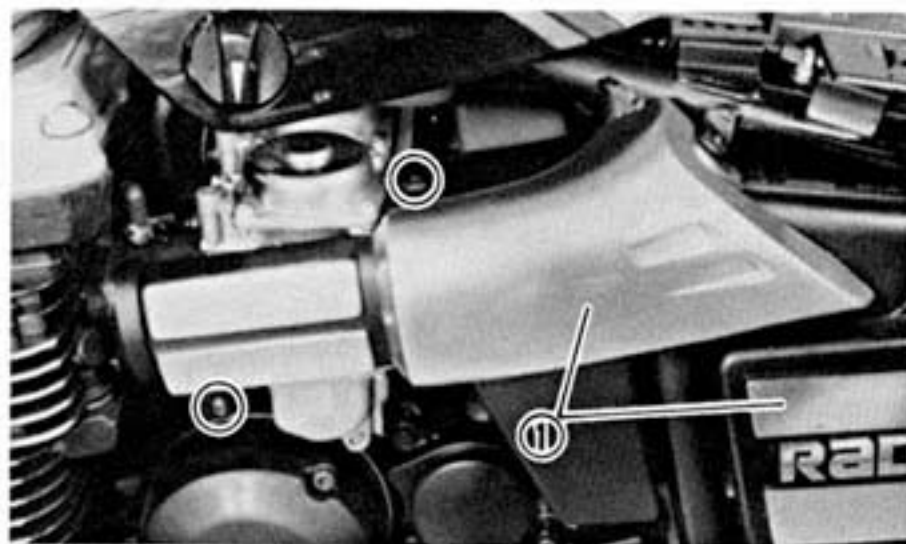

1. Cover

2. Remove the air filter case fitting screws and the filter case cover.



3. Pull out the element.

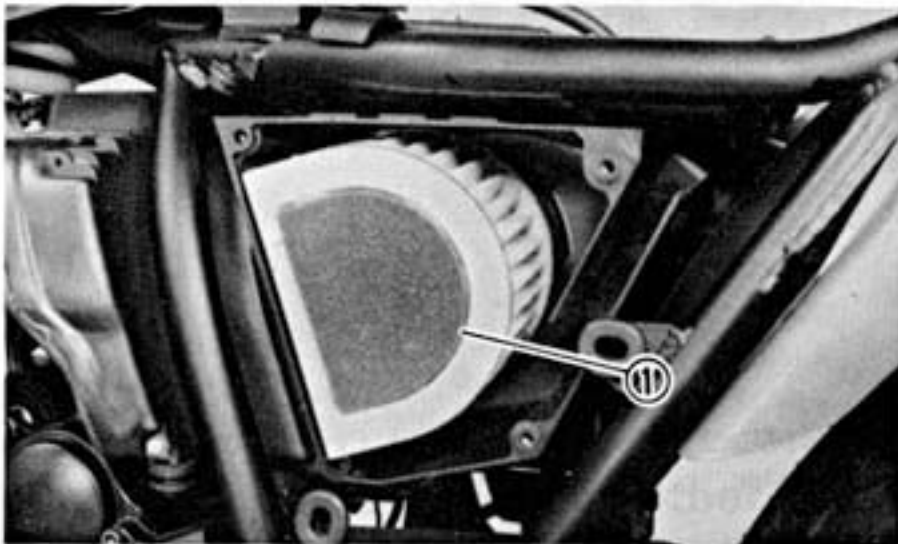

1. Air filter element

4. Tap the element lightly to remove most of the dust and dirt; blow out the remaining dirt with compressed air from the inner surface of the element. If the element is damaged, replace it.

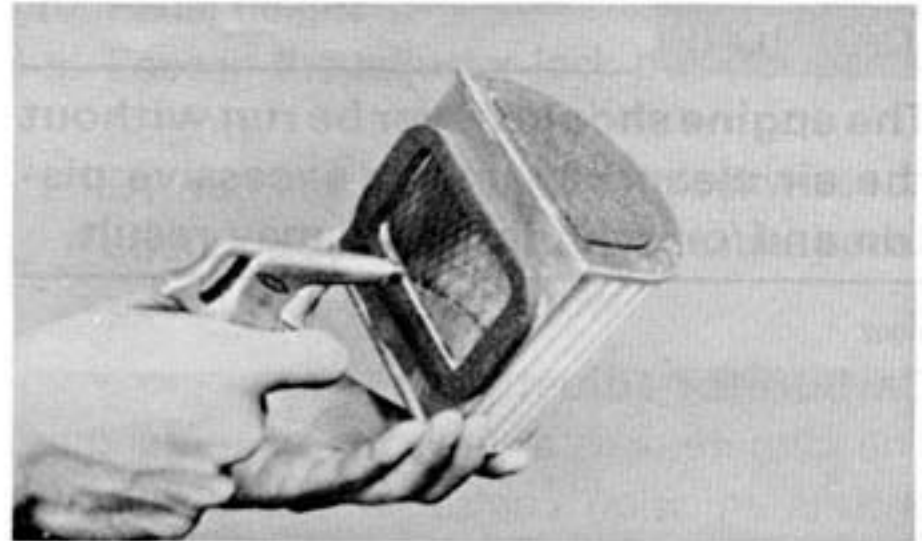

5. Reassemble by reversing the removal procedure.

U-357

CAUTION: _____

Make sure the element edge fits into the corresponding filter case groove.

6. The air filter element should be cleaned at the specified intervals.

CAUTION:

The engine should never be run without the air cleaner element; excessive piston and/or cylinder wear may result.

H-902

Carburetor adjustment

The carburetor is a vital part of the engine and its emission control system. Adjusting should be left to a Yamaha dealer or other qualified mechanic with the professional knowledge, specialized data, and equipment to do so properly.

H-800

Front brake adjustment

The free play at the end of the front brake lever should be 2 ~ 5 mm (0.08 ~ 0.20 in).

1. Loosen the lock nut.

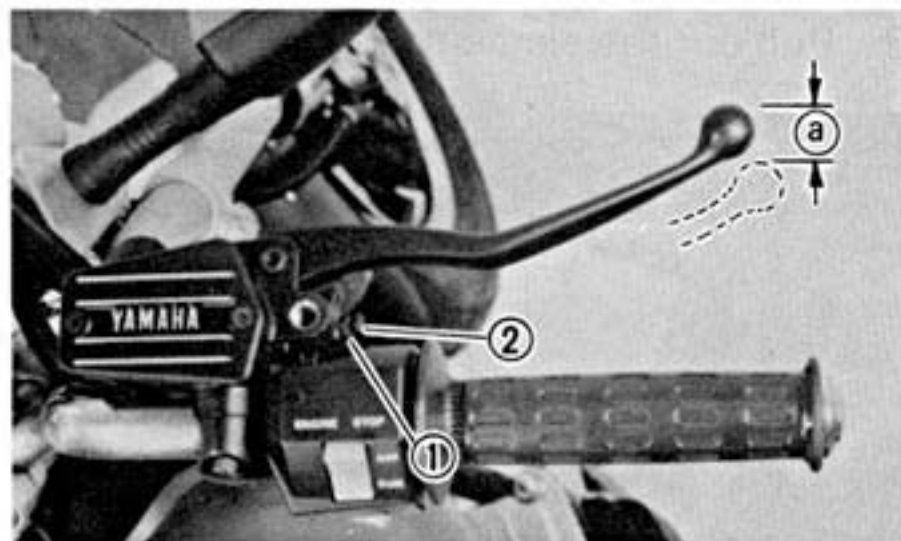

1. Adjuster 2. Lock nut a. 2 ~ 5 mm
(0.08 ~ 0.20 in)

2. Turn the adjuster so that the brake lever movement at the lever end is 2 ~ 5 mm (0.08 ~ 0.20 in) before the adjuster contacts the master cylinder piston.
3. After adjusting, tighten the lock nut.

U-636

WARNING:

Check the brake lever free play. Be sure the brake is working properly.

WARNING:

A soft or spongy feeling in the brake lever can indicate the presence of air in the brake system. This air must be removed by bleeding the brake system before the motorcycle is operated. Air in the system will cause greatly diminished braking capability and can result in loss of control and an accident. Have a Yamaha dealer or other qualified mechanic inspect and bleed the system if necessary.

Rear brake adjustment**WARNING:**

For brake pedal adjustment, be sure to proceed as follows: (It is advisable to have a Yamaha dealer or other qualified mechanic make this adjustment.)

1. Pedal height
 - a. Loosen the adjuster lock nut (for pedal height).
 - b. By turning the adjuster clockwise or counterclockwise, adjust the brake pedal position as shown below.

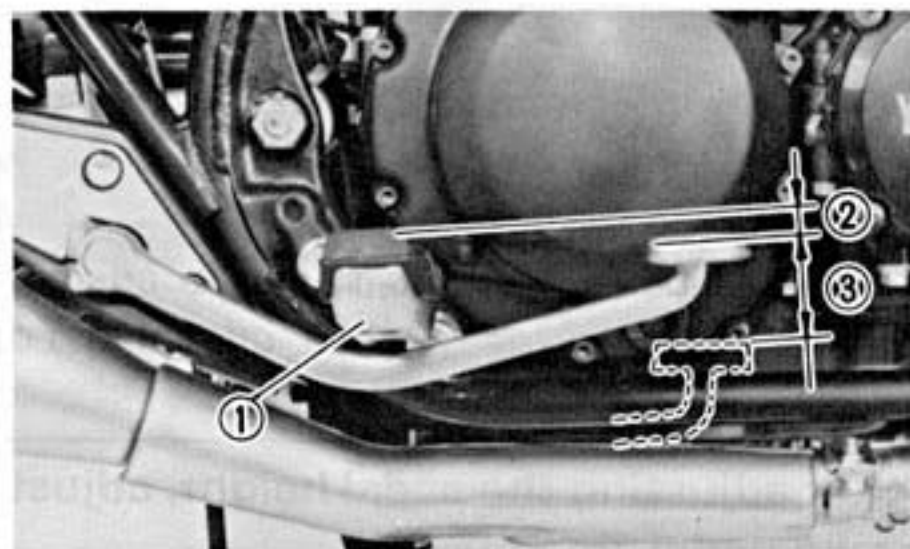

1. Footrest
2. Pedal height 15 mm (0.6 in)
3. Free play 20 ~ 30 mm (0.8 ~ 1.2 in)

c. Secure the adjuster lock nut.



1. Lock nut

2. Adjusting bolt

U-644

WARNING:

After adjusting the pedal height, adjust brake pedal free play.

2. Free play

The rear brake should be adjusted to suit the rider's preference; but free play at the brake pedal end must be 20 ~ 30 mm (0.8 ~ 1.2 in). Turn the adjuster on the

brake rod clockwise to reduce play; turn the adjuster counterclockwise to increase play.

U-698

WARNING:

1. The rear brake pedal adjustment must be checked anytime chain is adjusted or rear wheel is removed and then reinstalled.
2. Check the operation of the brake light after adjusting the rear brake.

H-833

Brake light switch adjustment

The brake light switch is operated by movement of the brake pedal. To adjust, hold the main body of the switch with your hand so it does not rotate and turn the adjusting nut. Proper adjustment is achieved when the brake light comes on just before the brake begins to take effect.

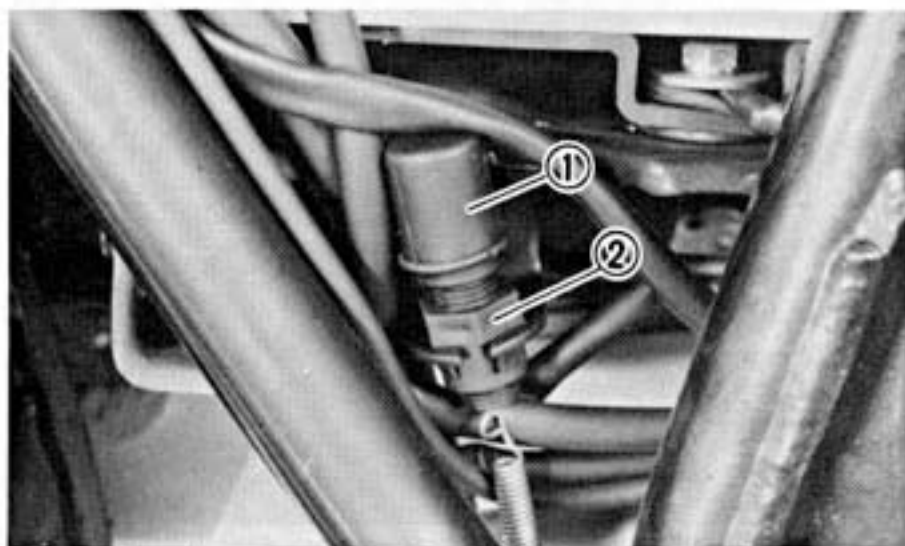
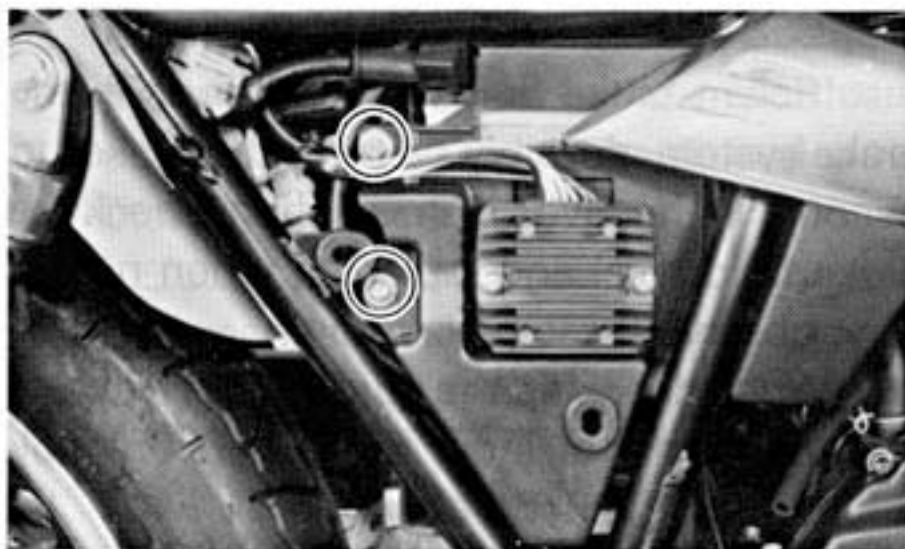

1. Main body

2. Adjusting nut

H-814

Checking the front brake pads and rear brake shoes

A wear indicator is attached to each brake to facilitate brake pad and shoe check. This indicator permits a visual check without disassembling the brake.

H-818

FRONT

To check, depress the brake and inspect the wear indicator. If the wear indicator is ALMOST in contact with the disc plate, ask a Yamaha dealer or other qualified mechanic to replace the pads.

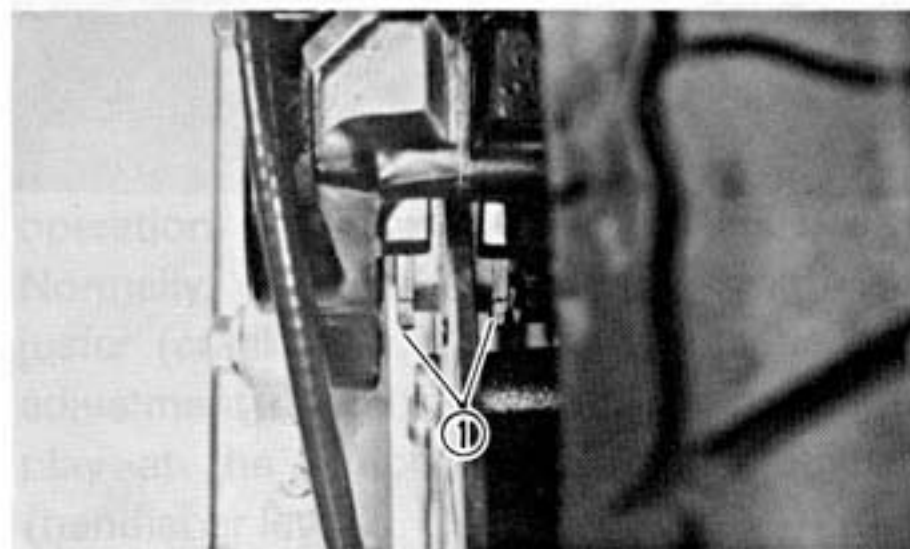

1. Wear indicator

REAR

To check, look at the wear indicator while depressing the brake pedal. If the indicator reaches the wear limit line, ask a Yamaha dealer or other qualified mechanic to replace the shoes.

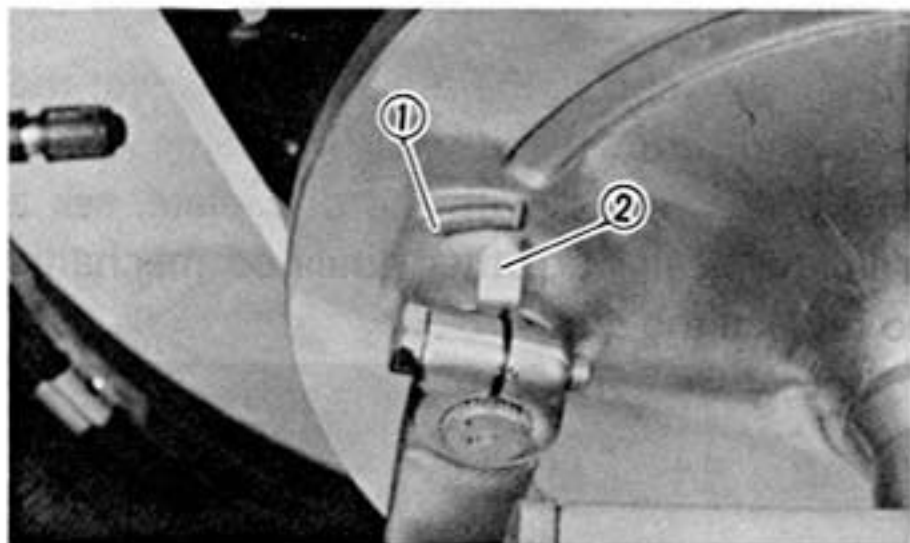

1. Wear limit

2. Wear indicator

Inspecting the brake fluid level

Insufficient brake fluid may let air enter the brake system, possibly causing the brakes to become ineffective. Before riding, check the brake fluid level and replenish when necessary; observe these precautions:

1. When checking the fluid level, make sure the master cylinder top is horizontal by turning the handlebars.

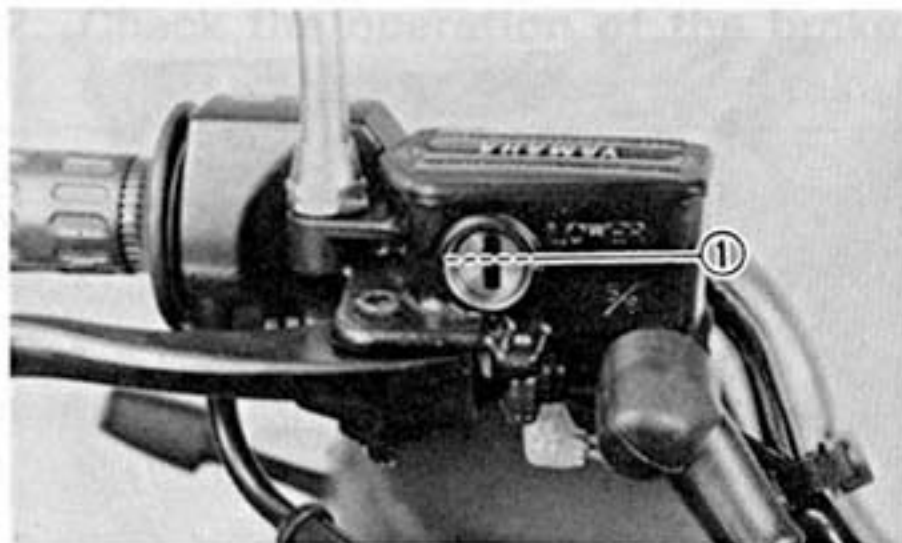

1. Lower level

2. Use only the designated quality brake fluid: otherwise, the rubber seals may deteriorate, causing leakage and poor brake performance.

Recommended brake fluids:
DOT #3

3. Refill with the same type of brake fluid; mixing fluids may result in a harmful chemical reaction and lead to poor performance.
4. Be careful that water does not enter the master cylinder when refilling. Water will significantly lower the boiling point of the fluid and may result in vapor lock.
5. Brake fluid may erode painted surfaces or plastic parts. Always clean up spilled fluid immediately.
6. Have a Yamaha dealer or other qualified mechanic check the cause if the brake fluid level goes down.

H-840

Brake fluid replacement

1. Complete fluid replacement should be done only by trained Yamaha service personnel or other qualified mechanic.
2. Have a Yamaha dealer or other qualified mechanic replace the following components when indicated in the schedule or when they are damaged or leaking.
 - a. Replace all rubber seals every two years.
 - b. Replace all hoses every four years.

--001

Clutch adjustment

This model has two clutch cable length adjusters. The cable length adjusters are used to take up slack from cable stretch and to provide sufficient free play for proper clutch operation.

Normally, once the clutch cable length adjuster (crankcase) is properly set; the only adjustment required is maintenance of free play at the clutch cable length adjuster (handlebar lever).

Free play adjustment

The clutch should be adjusted to suit the rider's preference; but, free play at the lever pivot should be 2~3 mm (0.08~0.12 in).

Clutch lever free play:

2~3 mm (0.08~0.12 in)

1. Handlebar lever side

Turn the cable length adjuster either in or out until suitable adjustment is obtained.

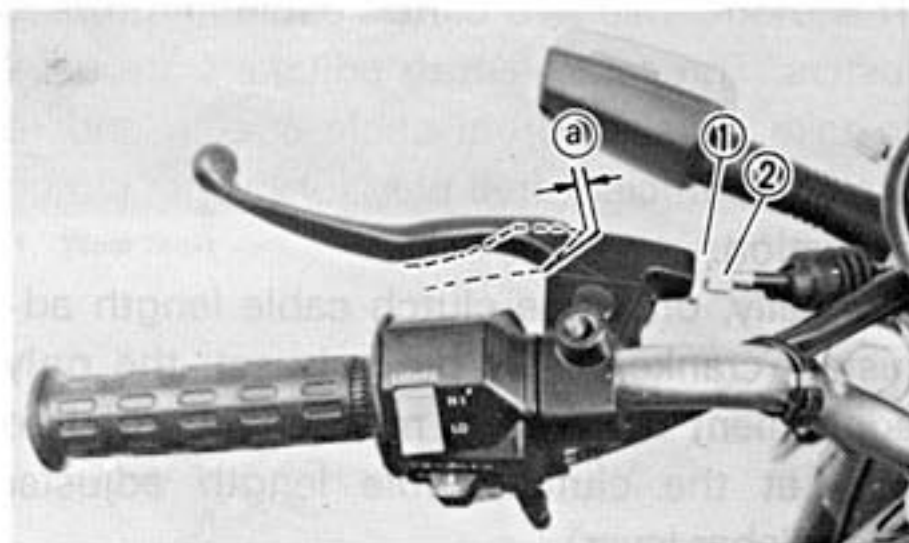

1. Lock nut 2. Adjuster a. 2~3 mm
(0.08~0.12 in)

CAUTION:

Turn the adjuster until you hear a click. Do not leave the adjuster between settings.

2. Crankcase side

Loosen the handlebar lever adjuster lock nut. Next turn the length adjuster either in or out until proper lever free play is achieved.

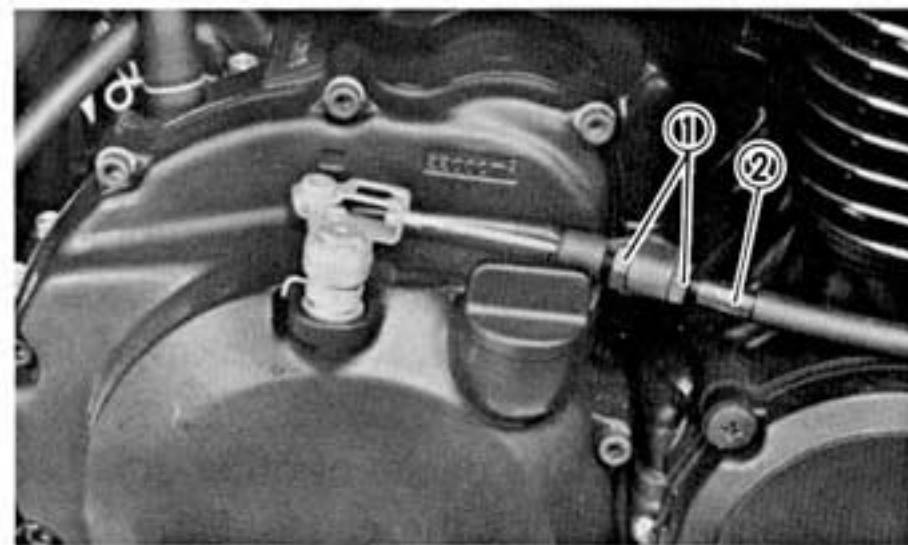

1. Lock nut 2. Adjuster

Drive chain slack check

NOTE:

Before checking and/or adjusting the chain slack, rotate the rear wheel through several revolutions. Check the chain slack several times to find the point where the chain is the tightest. Check and/or adjust the chain slack where the rear wheel is in this "tight chain" position.

Inspect the drive chain when the motorcycle is on the centerstand. Check the slack at the position shown in the illustration. The normal vertical deflection is approximately 20 ~ 30 mm (0.8 ~ 1.2 in). If the deflection exceeds 30 mm (1.2 in), adjust the chain slack.

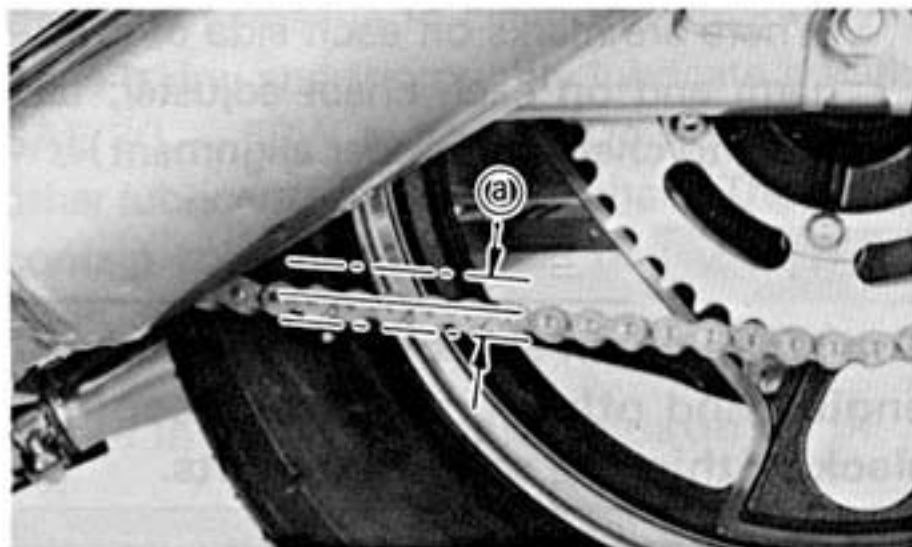

a. 20 ~ 30 mm (0.8 ~ 1.2 in)

Drive chain slack adjustment

1. Loosen the rear brake adjuster.
2. Remove the cotter pin from the rear wheel axle nut.
3. Loosen the rear wheel axle nut.
4. Loosen the lock nuts on each side. To tighten the chain, turn chain adjuster clockwise. To loosen the chain, turn the adjuster counterclockwise and push the wheel forward. Turn each adjuster exactly the same amount to maintain correct axle alignment.

(There are marks on each side of swingarm and on each chain adjuster; use them to check for proper alignment).

U-333

CAUTION:

Too small chain slack will overload the engine and other vital parts; keep the slack within the specified limits.

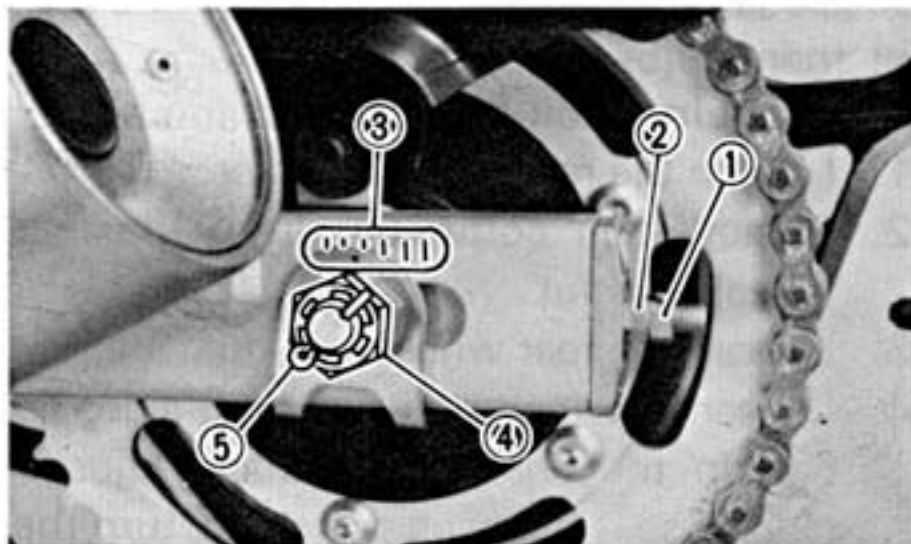

- | | |
|------------------------|-------------|
| 1. Lock nut | 2. Adjuster |
| 3. Marks for alignment | 4. Axle nut |
| 5. Cotter pin | |

5. After adjusting, be sure to tighten the lock nuts and the axle nut.

Axle nut torque:
105 Nm (10.5 m·kg, 75 ft·lb)

6. Insert a new cotter pin into the rear wheel axle nut and bend the end of the cotter pin as shown in the illustration. (If the nut notch and the cotter pin hole do not match tighten the nut slightly to align them.)

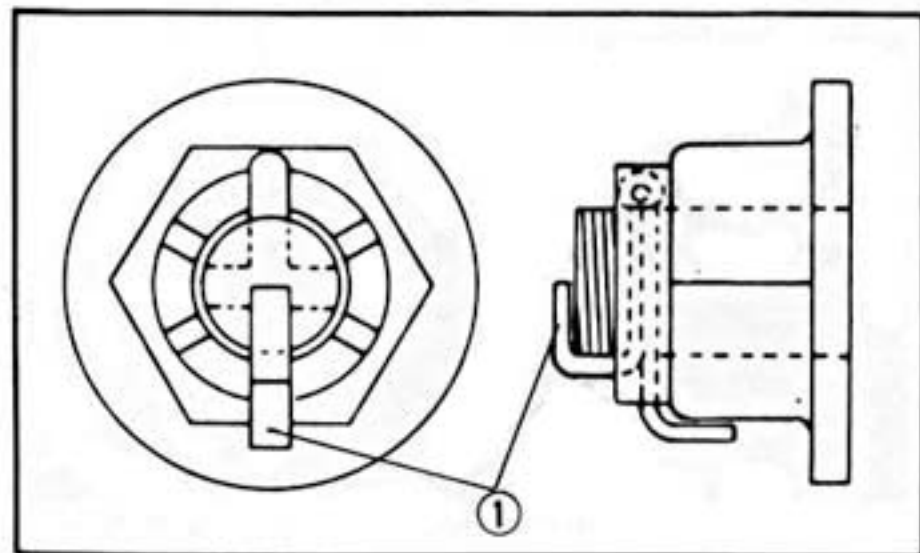

1. Cotter pin

WARNING:

Always use a new cotter pin on the axle nut.

7. Adjust the free play in the brake pedal.

WARNING:

Check the operation of the brake light after adjusting the rear brake.

Drive chain lubrication

The chain consists of many parts which work against each other. If the chain is not maintained properly, it will wear out rapidly, therefore, form the habit of periodically servicing the chain. This service is especially necessary when riding in dusty conditions. This motorcycle has a drive chain with small rubber O-rings between the chain plates. Steam cleaning, high-pressure washes, and certain solvent can damage these O-rings.

Use only kerosene to clean the drive chain. Wipe it dry, and thoroughly lubricate it with SAE 30 ~ 50W motor oil. Do not use any other lubricants on the drive chain. They may contain solvents that could damage the O-rings.

Cable inspection and lubrication**WARNING:**

Damage to the outer housing of the various cables may cause corrosion and interfere with the movement of the cable. An unsafe condition may result so replace such cables as soon as possible.

Lubricate the inner cable and the cable end. If they do not operate smoothly, ask a Yamaha dealer or other qualified mechanic to replace them.

Recommended lubricant:

Yamaha Chain and Cable Lube or
SAE 10W30 motor oil

I-102

Throttle cable and grip lubrication

The throttle twist grip assembly should be greased at the time that the cable is lubricated, since the grip must be removed to get at the end of the throttle cable. Two screws clamp the throttle housing to the handlebar. Once these two are removed, the end of the cable can be held high to pour in several drops of lubricant. With the throttle grip disassembled, coat the metal surface of the grip assembly with a suitable all-purpose grease.

I-302

Brake and change pedals

Lubricate the pivoting parts.

Recommended lubricant:

Yamaha Chain and Cable Lube or
SAE 10W30 motor oil

I-303

Brake and clutch levers

Lubricate the pivoting parts.

Recommended lubricant:

Yamaha Chain and Cable Lube or
SAE 10W30 motor oil

I-304

Center and sidestand

Lubricate the pivoting parts. Check to see that the center and sidestand move up and down smoothly.

Recommended lubricant:

Yamaha Chain and Cable Lube or
SAE 10W30 motor oil

WARNING:

If the center and/or sidestand movement are not smooth, consult a Yamaha dealer or other qualified mechanic.

Rear suspension

Lubricate the pivoting parts.

Recommended lubricant:

Swingarm pivots: Bearing grease

Other pivots: Lithium soap base grease

Front fork oil change**WARNING:**

1. Fork oil leakage can cause loss of stability and safe handling. Have any problem corrected before operating the motorcycle.

2. Securely support the motorcycle so there is no danger of it falling over.

1. Elevate the front wheel by placing a suitable stand under the engine. Remove the handlebars.

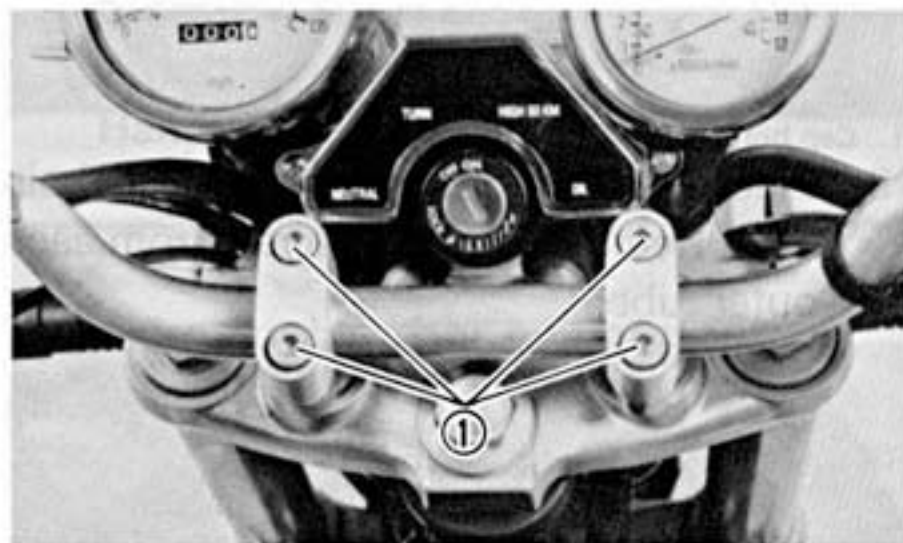

1. Handlebar securing bolt
2. Loosen the front fork pinch bolts, and remove the cap bolts from the inner fork tubes.

WARNING:

Do not let oil contact the disc brake components. If any oil should contact the brake components, it must be removed before the motorcycle is operated. Oil will cause diminished braking capacity and will damage the rubber components of the brake assembly.

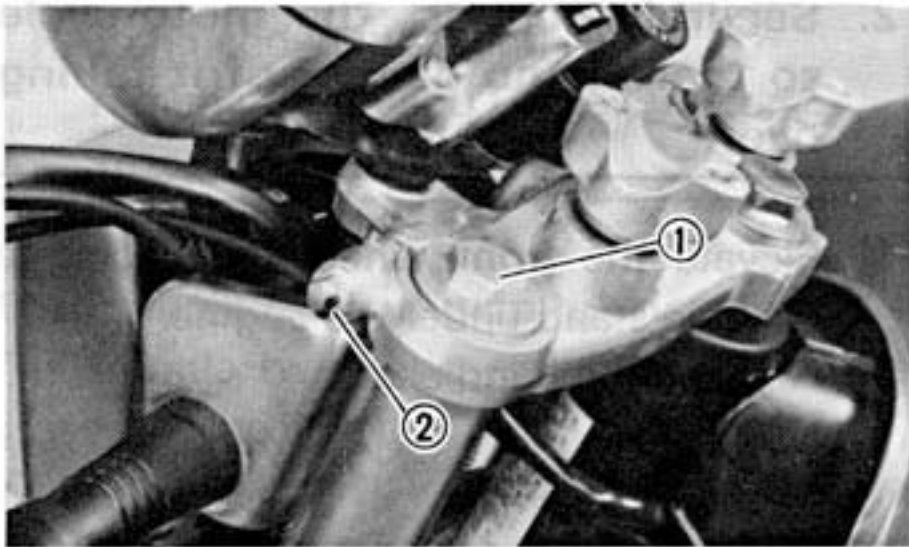

1. Cap bolt

2. Pinch bolt

- Place an open container under each drain hole. Remove the drain screw from each outer tube.

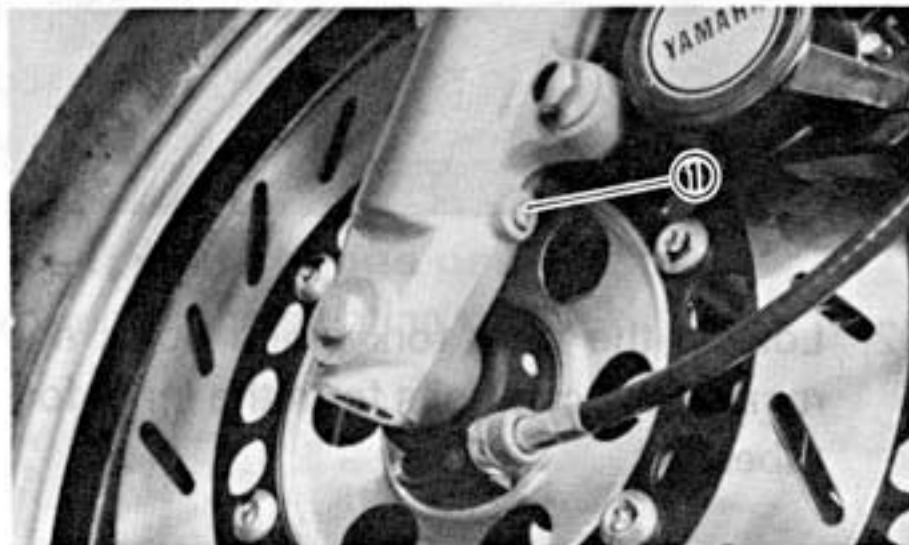

1. Drain screw

- After most of the oil has been drained, slowly pump the forks up and down to remove any remaining oil.
- Inspect the drain screw gasket. Replace if damaged. Reinstall the drain screws.
- Pour the specified amount of oil into each fork inner tube.

Front fork oil capacity (each fork):
 320 cm³ (11.3 Imp oz, 10.8 US oz)
 Recommended oil:
 Yamaha Fork Oil 10WT or equivalent

7. After filling, slowly pump the forks up and down to distribute the oil.
8. Inspect the O-ring on the cap bolts.. Replace if damaged.



1. O-ring

9. Reinstall the cap bolt and tighten the pinch bolt.

Tightening torque:

Cap bolt:

23 Nm (2.3 m·kg, 17 ft·lb)

Pinch bolt torque:

23 Nm (2.3 m·kg, 17 ft·lb)

10. Install the handlebar assembly.

Tightening torque:

Handlebar:

20 Nm(2.0 m·kb,14 *ft·lb)

I-509

Rear shock absorber adjustment

Spring preload

If the spring seat is raised, the spring becomes stiffer, and if lowered, it becomes softer.

Standard position: 2

5. — Softest

1. — Stiffest

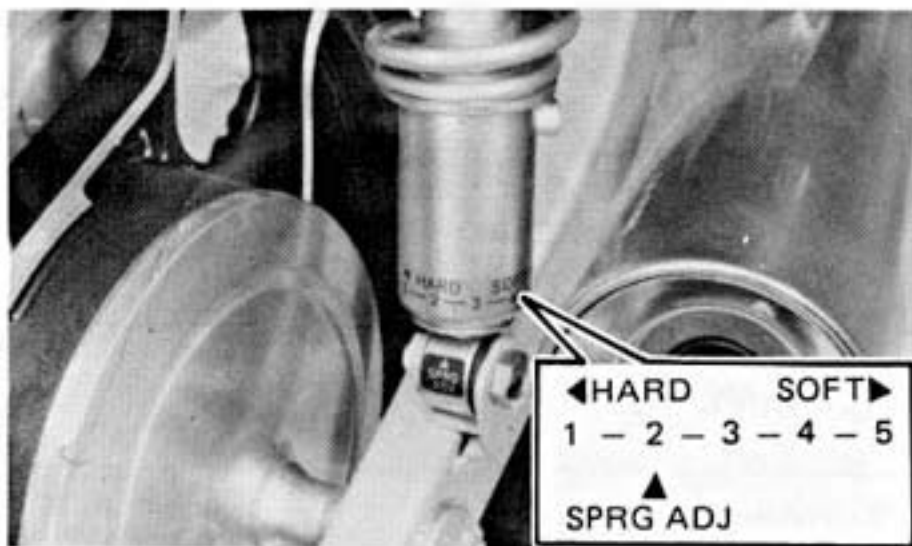

U-652

WARNING:

Always adjust each shock absorber to the same setting. Uneven adjustment can cause poor handling and loss of stability.

I-600

Steering inspection

Periodically inspect the condition of the steering. Worn out or loose steering bearings may be dangerous.

Place a block under the engine to raise the front wheel off the ground.

Hold the lower end of the front forks and try to move them forward and backward. If any free play can be felt, ask a Yamaha dealer or other qualified mechanic to inspect and adjust the steering. Inspection is easier if the front wheel is removed.

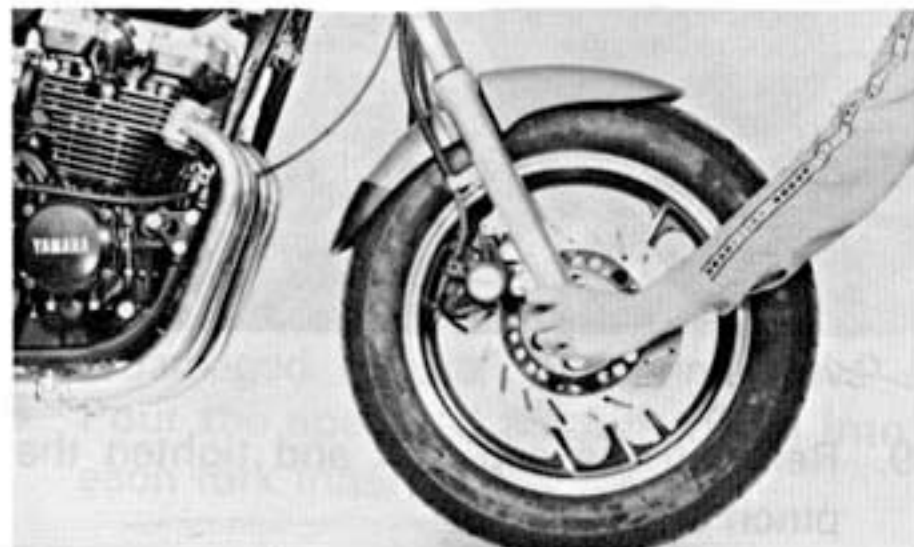

U-657

WARNING:

Securely support the motorcycle so there is no danger of it falling over.

Wheel bearings

If the wheel bearings in the front or rear wheel allow play in the wheel hub or if the wheel does not turn smoothly, have a Yamaha dealer or a qualified mechanic inspect the wheel bearings. The wheel bearings should be inspected according to the General Maintenance Schedule.

Battery

Check the level of the battery electrolyte and see that the terminals are tight. Add distilled water if the electrolyte level is low.

CAUTION:

When inspecting the battery, be sure the breather pipe is routed correctly. If the breather pipe touches the frame or exits in such a way as to cause battery electrolyte or gas to exit onto the frame, structural and cosmetic damage to the motorcycle can occur.

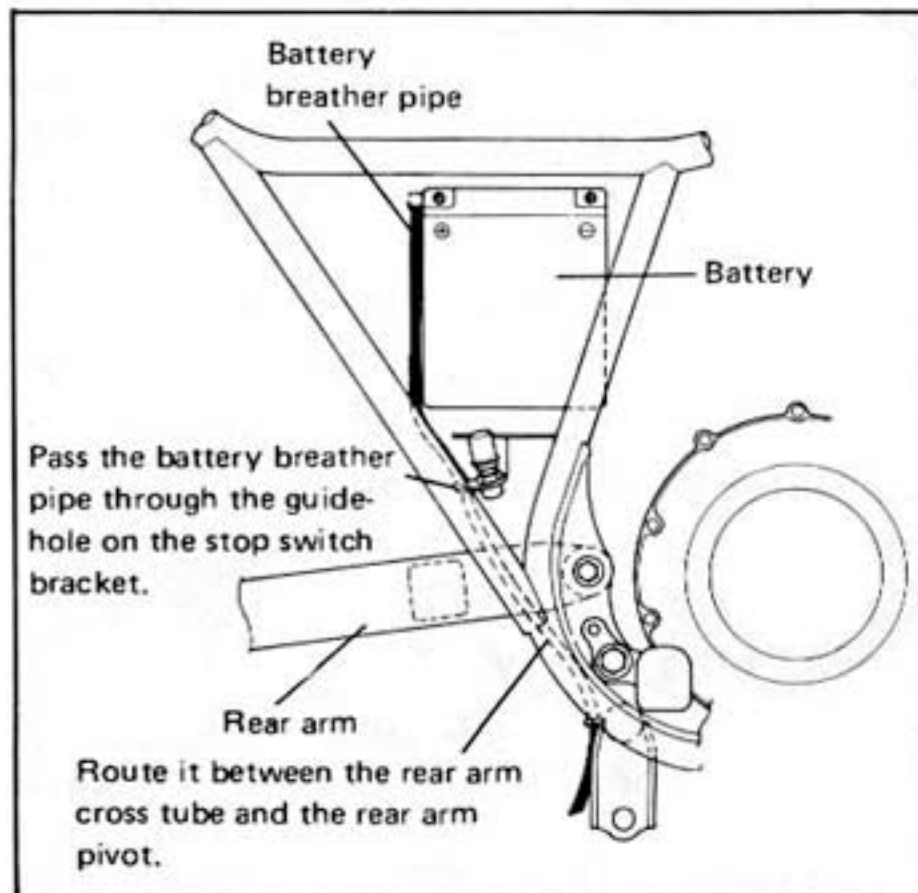

WARNING:

Battery electrolyte is poisonous and dangerous, causing severe burns, etc. It contains sulfuric acid. Avoid contact with skin, eyes or clothing.

Antidote: EXTERNAL-Flush with water. INTERNAL-Drink large quantities of water or milk. Follow with milk of magnesia, beaten egg, or vegetable oil. Call a physician immediately.

Eyes: Flush with water for 15 minutes and get prompt medical attention. Batteries produce explosive gases. Keep sparks, flame, cigarettes etc., away. Ventilate when charging or using in an enclosed space. Always shield your eyes when working near batteries. **KEEP OUT OF REACH OF CHILDREN.**

Replenishing the battery fluid

A poorly maintained battery will deteriorate quickly. The battery fluid should be checked at least once a month.

1. The level should be between the upper and lower level marks. Use only distilled water if refilling is necessary.



1. Upper level

2. Lower level

CAUTION:

Normal tap water contains minerals which are harmful to a battery; therefore, refill only with distilled water.

WARNING:

Battery fluid on the chain can cause premature failure and possibly an accident.

2. When the motorcycle will not be used for a month or longer, remove the battery and store it in a cool, dark place. Completely recharge the battery before reusing.
3. If the battery will be stored for a longer period than the above, check the specific gravity of the fluid at least once a month and recharge the battery when it is too low.

4. Always make sure the connections are correct when putting the battery back in the motorcycle.

Make sure the breather pipe is properly connected and is not damaged or obstructed.

Fuse replacement

1. The fuse block is located under the seat.

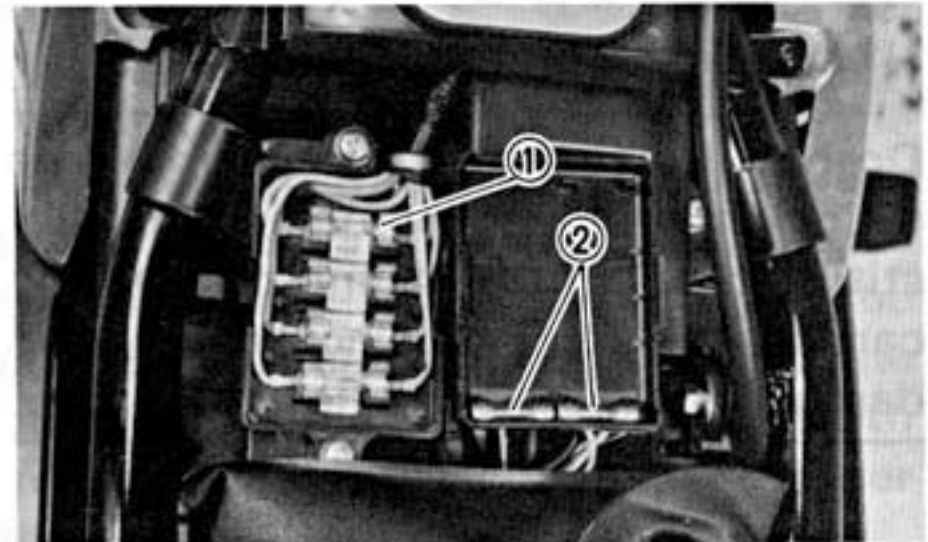

1. Fuse

2. Spare fuse

2. If any fuse is blown, turn off the ignition switch and the switch in the circuit in question. Install a new fuse of proper amperage.

Turn on the switches, and see if the electrical device operates. If the fuse immediately blows again, consult a Yamaha dealer or other qualified mechanic.

U-344

CAUTION:

Do not use fuses of higher amperage rating than those recommended. Substitution of a fuse of improper rating can cause extensive electrical system damage and possibly a fire.

I-800

Replacing the headlight bulb

This motorcycle is equipped with a quartz bulb headlight. If the headlight bulb burns out, replace the bulb as follows:

1. Remove the 2 screws holding the light unit assembly.

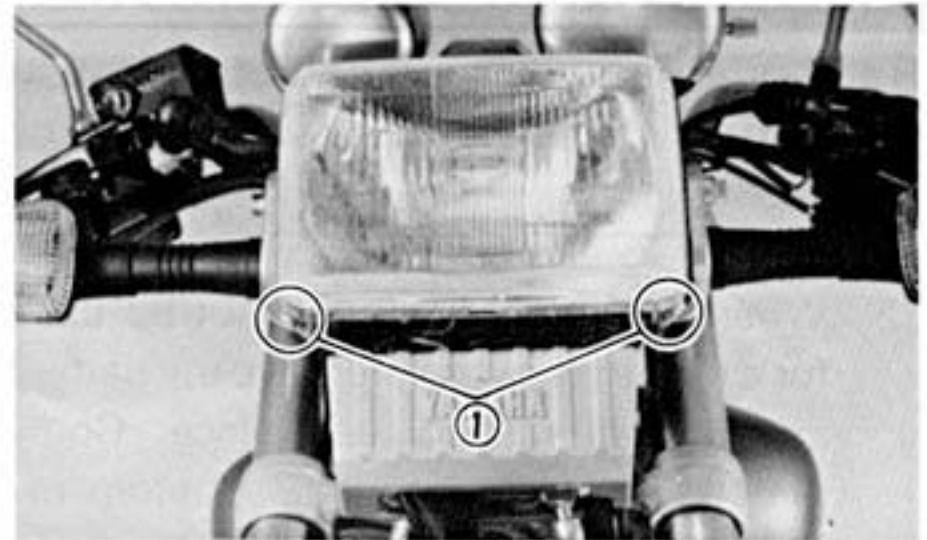

1. Holding screw

2. Disconnect the lead wires, and remove the light unit assembly.

WARNING:

Keep flammable products or your hands away from the bulb while it is on, it will be hot. Do not touch the bulb until it cools down.

- Slip a new bulb into position and secure it in place with the bulb holder.

CAUTION:

Avoid touching the glass part of the bulb. Keep it free from oil; otherwise, the transparency of the glass, life of the bulb, and illuminous flux will be adversely affected. If oil gets on the bulb, thoroughly clean it with a cloth moistened with alcohol or lacquer thinner.

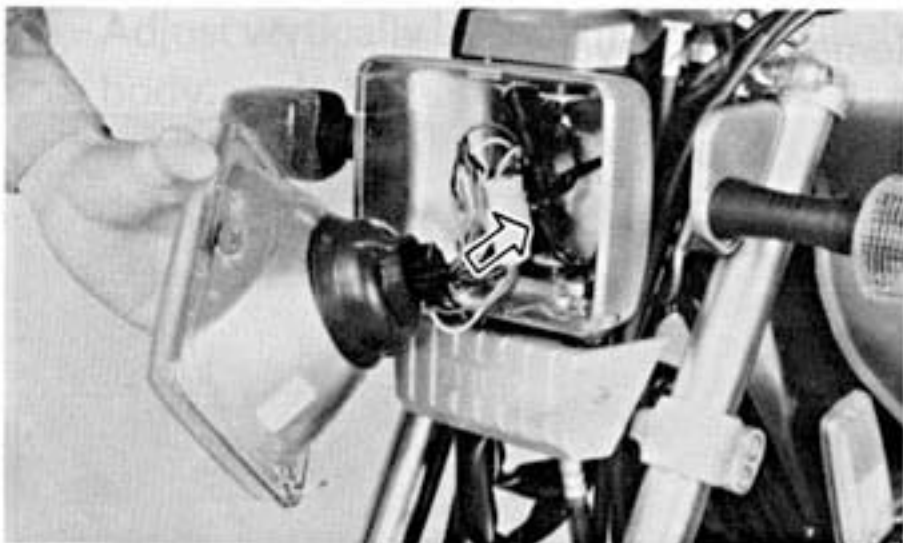

- Turn the bulb holder counterclockwise and remove the defective bulb.

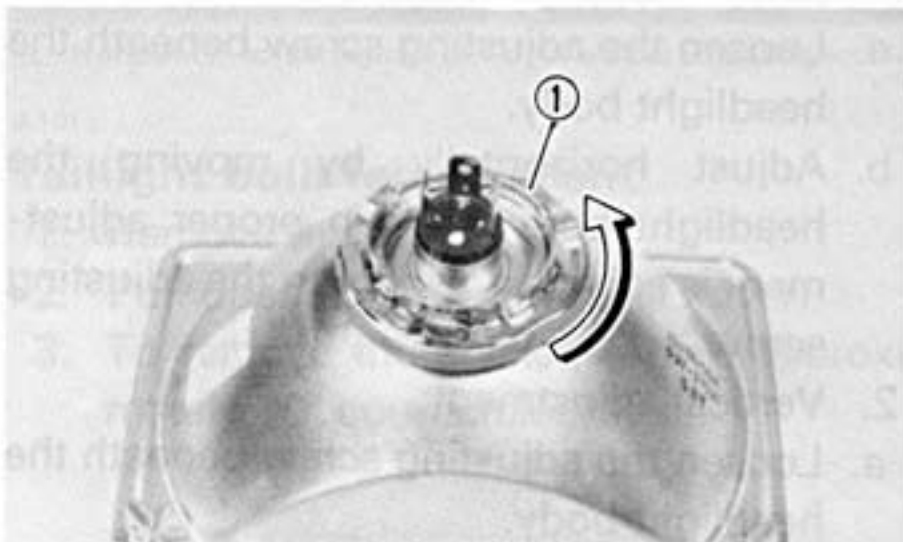

1. Bulb holder

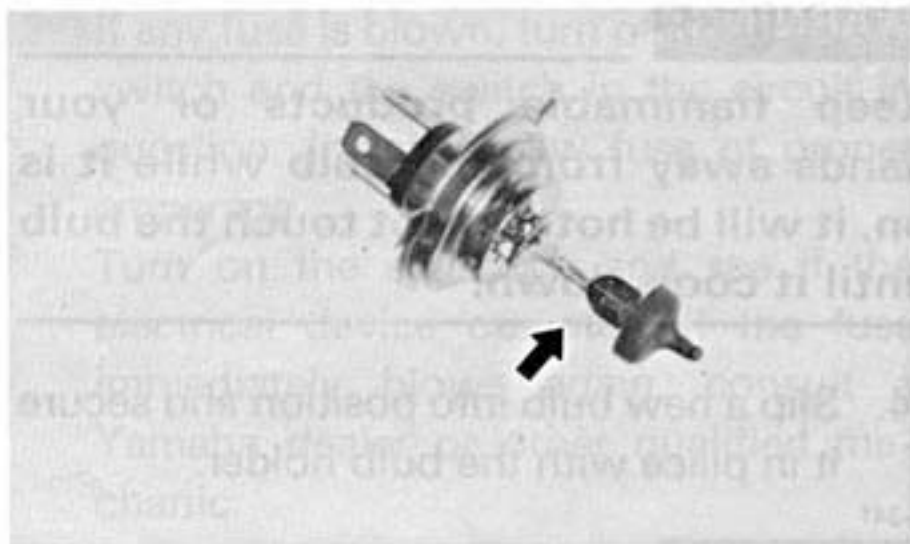

5. Reinstall the light unit assembly. Adjust the headlight beam if necessary.

I-827K

Headlight beam adjustment

U-343

CAUTION:

For the headlight beam adjustment, be sure to proceed as follows; (It is advisable to have a Yamaha dealer make this adjustment.)

Remove the cover

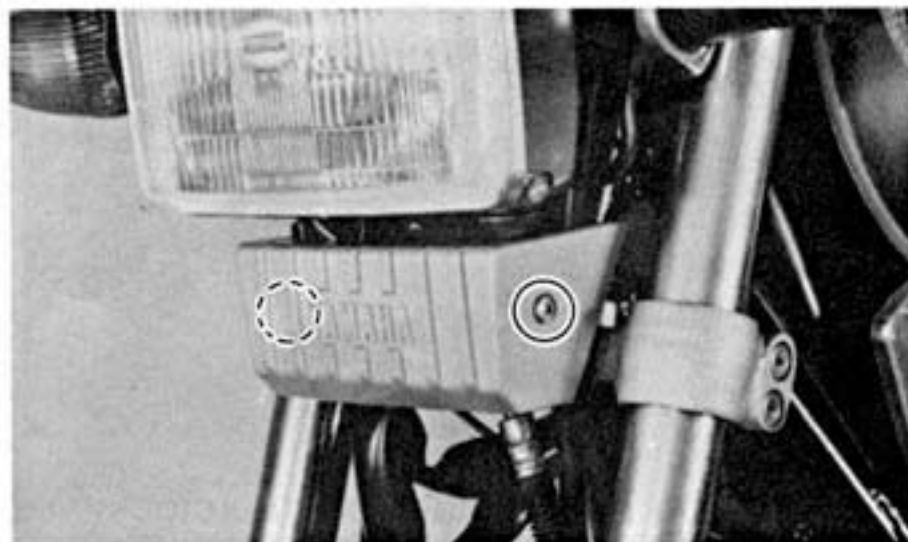

1. Horizontal adjustment:
 - a. Loosen the adjusting screw beneath the headlight body.
 - b. Adjust horizontally by moving the headlight body. When proper adjustment is achieved, retighten the adjusting screw.
2. Vertical adjustment:
 - a. Loosen the adjusting screw beneath the headlight body.

- b. Adjust vertically by moving the headlight body. When proper adjustment is achieved, retighten the adjusting screw.

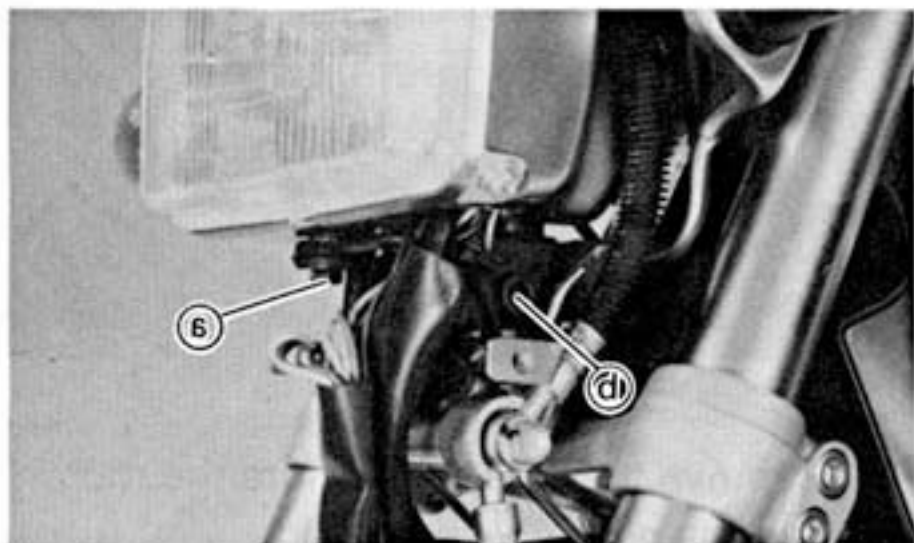

a. Horizontal adjusting screw b. Vertical adjusting screw

J-101

Taillight bulb replacement

1. Remove the seat.
2. Pull open the lid in the seat cover.
3. To remove the socket, turn it approximately 30° counterclockwise.

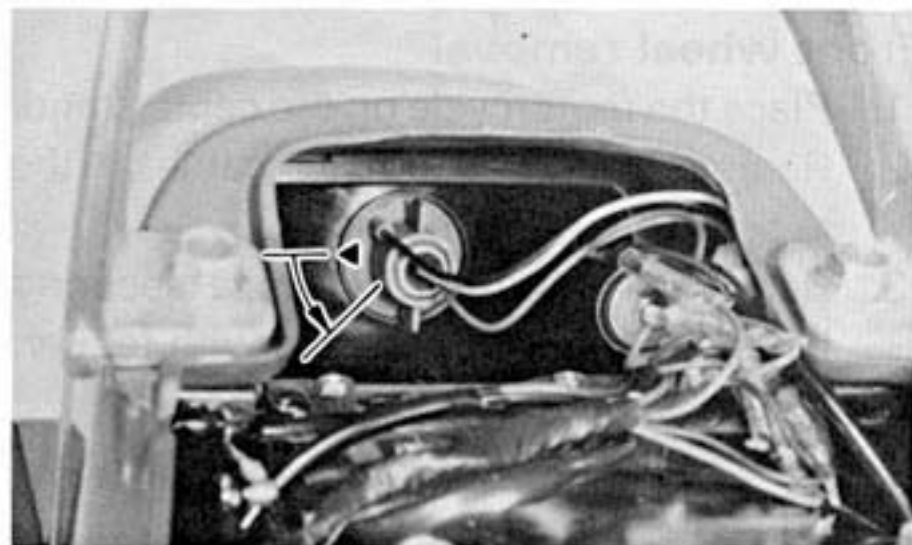

4. Turn the bulb counterclockwise and remove the defective bulb.
5. Push a new bulb into position and turn it clockwise.
6. To install the socket, reverse the removal procedure.

Front wheel removal

1. Place the motorcycle on the centerstand.
2. Remove the speedometer cable at the speedometer gear housing.
3. Remove the front fork brace securing bolts and remove the brace with fender.

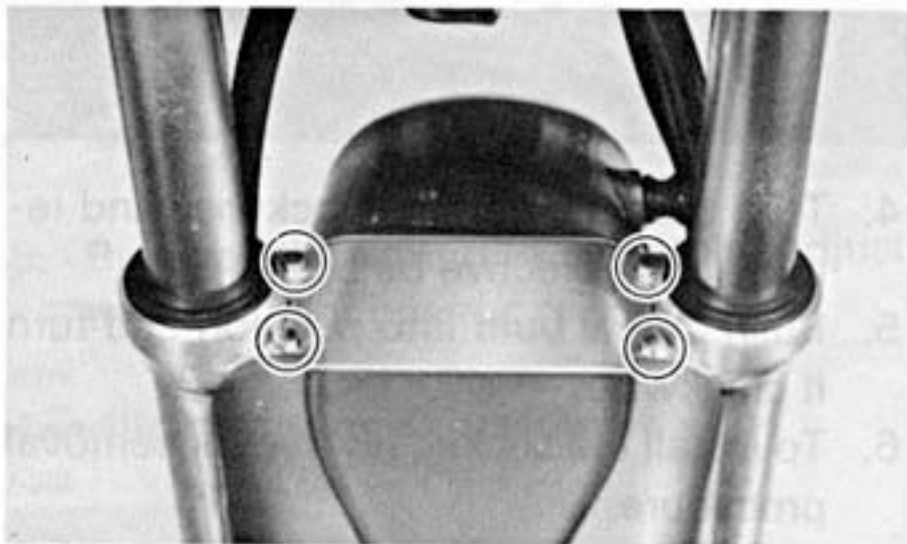

4. Loosen the pinch bolt.

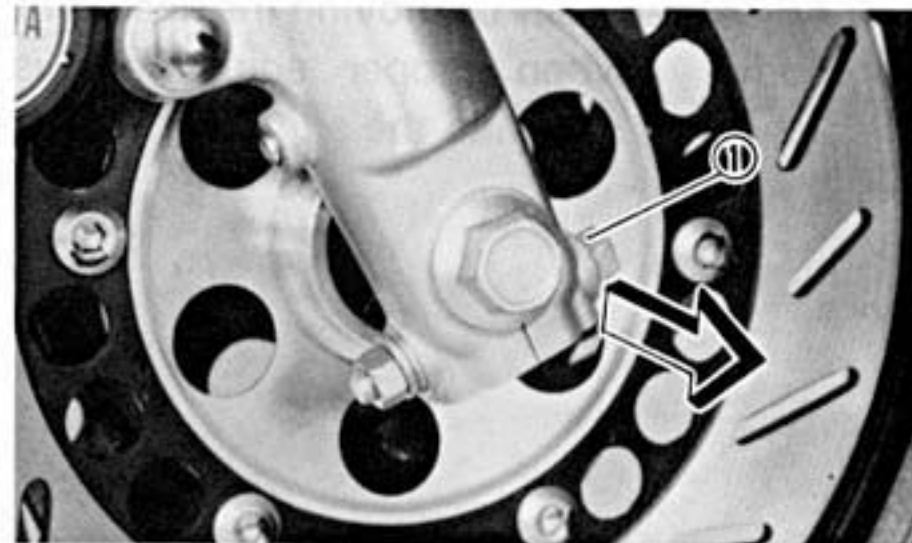

1. Pinch bolt

5. Remove the axle. Make sure the motorcycle is properly supported.

U-054

NOTE: _____
Do not depress the brake lever when the disc is off the caliper as the brake pads will be forced shut.

6. Lower the wheel until the discs come off the calipers. Turn the calipers outward so they do not obstruct the wheel and remove the wheel.

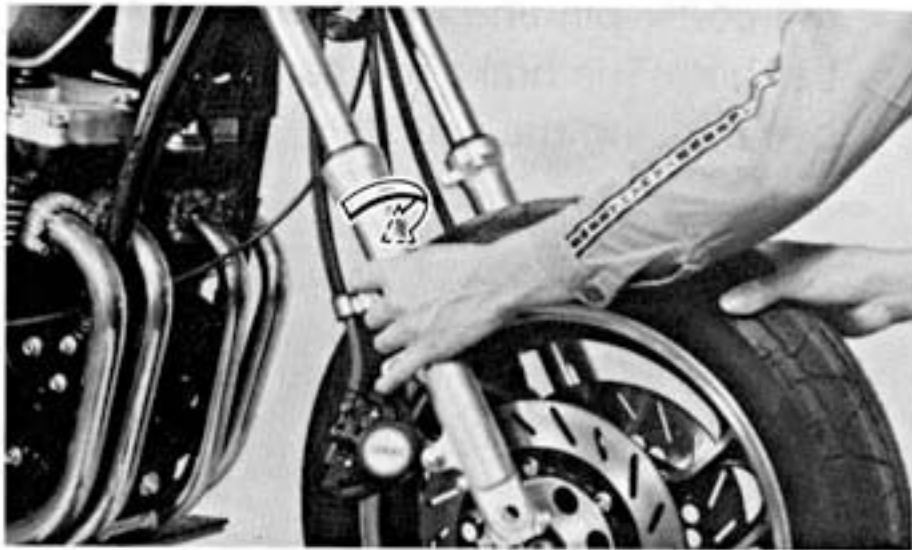

J-217

Front wheel installation

When installing the front wheel, reverse the removal procedure.

Pay attention to the following points:

1. Make sure the wheel hub and the speedometer clutch assembly are installed with the projections meshed into the slots.

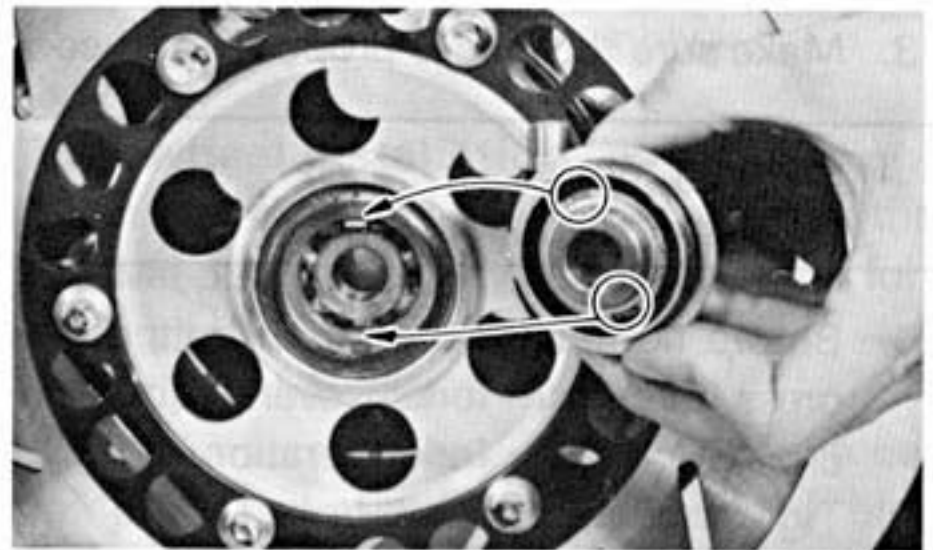

2. Make sure the projecting portion (torque stopper) of the speedometer housing is positioned correctly.

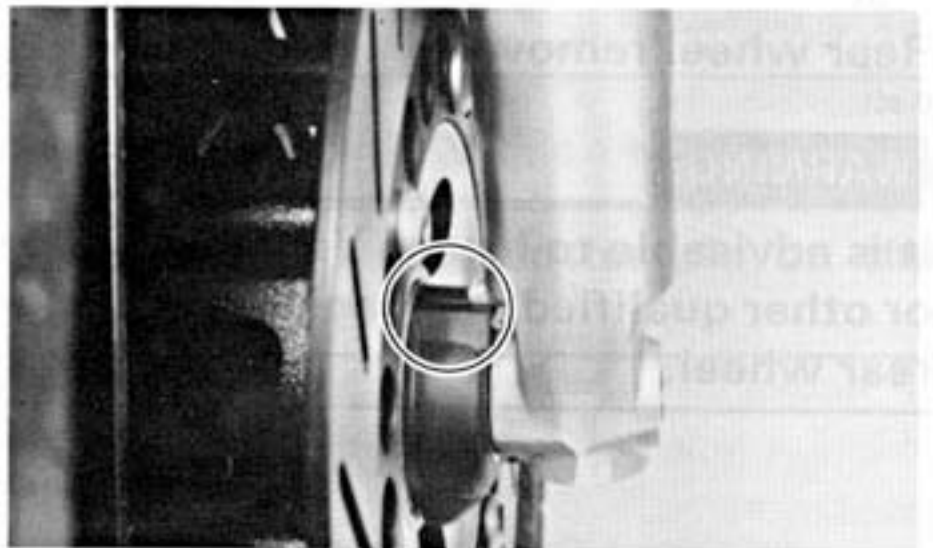

7-39

3. Make sure the axle is properly torqued.

Tightening torque:

105 Nm (10.5 m·kg, 75 ft·lb)

4. Before tightening the pinch bolt, compress the front forks several times to check for proper fork operation.
5. Tighten the axle pinch bolt.

Axle pinch bolt torque:

20 Nm (2.0 m·kg, 14 ft·lb)

J-341K

Rear wheel removal

U-661

WARNING:

It is advisable to have a Yamaha dealer or other qualified mechanic service the rear wheel.

1. Place the motorcycle on the centerstand.
2. Remove the tension bar and the brake rod from the brake shoe plate. The tension bar can be removed by removing the cotter pin and nut from the tension bar bolt. The brake rod can be removed by removing the adjuster.

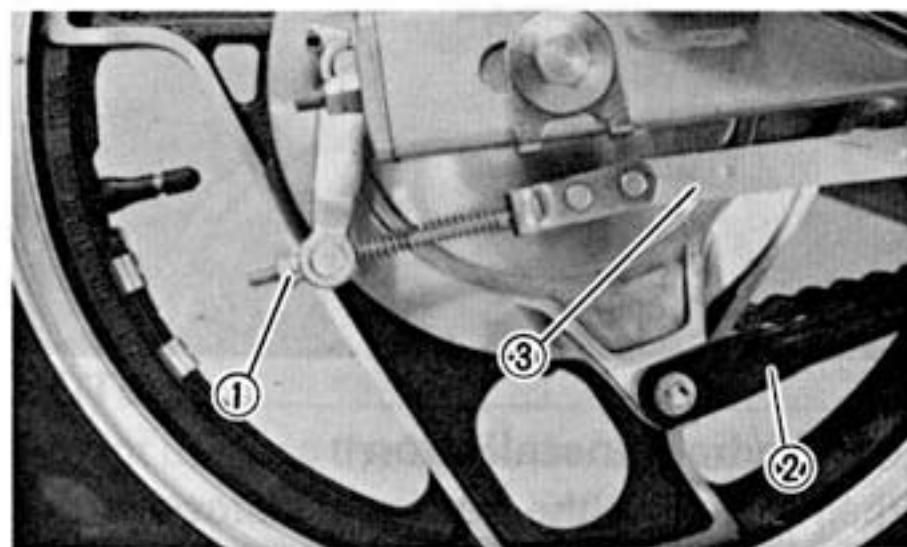

1. Adjuster 2. Brake rod 3. Tension bar

3. Remove the axle nut cotter pin and the axle nut.

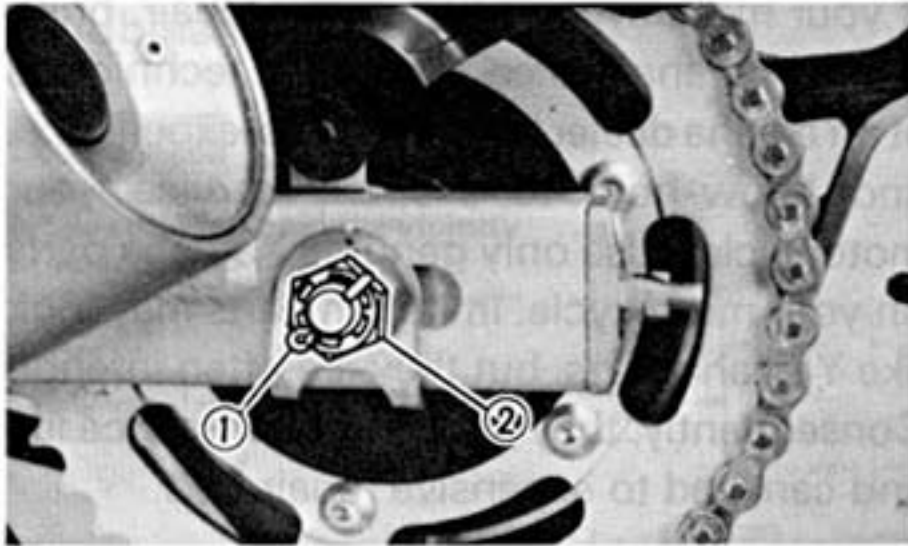

1. Cotter pin 2. Axle nut

4. Push the wheel forward and remove the drive chain.



5. Remove the wheel assembly.

J-340K

Rear wheel installation

When installing the rear wheel, reverse the removal procedure. Pay attention to the following points:

1. Adjust the drive chain.
2. Make sure the axle nut and tension bar bolt are properly torqued, and a new cotter pin is installed.

U-647

WARNING: _____

Always use a new cotter pin on the axle nut.

U-716

WARNING: _____

Always use a new cotter pin on the tension bar bolt.

Tightening torque:

Axle nut:

105 Nm (10.5 m·kg, 75 ft·lb)

Tension bar bolt:

20 Nm (2.0 m·kg, 14 ft·lb)

3. Adjust the rear brake. (See page 7-17.)

U-645

WARNING:

Check the operation of the brake light after adjusting the rear brake.

J-500

Troubleshooting

Although Yamaha motorcycles receive a rigid inspection before shipment from the factory, trouble may occur during operation. Any problem in the fuel, compression, or ignition systems can cause poor starting and a loss of power. The troubleshooting chart describes a quick, easy procedure for checking these systems.

If your motorcycle requires any repair, bring it to a Yamaha dealer. The skilled technicians at a Yamaha dealer have the tools, experience, and know-how to properly service your motorcycle. Use only genuine Yamaha parts on your motorcycle. Imitation parts may look like Yamaha parts, but they are often inferior. Consequently, they have a shorter service life and can lead to expensive repair bills.

Troubleshooting chart

U-663

WARNING:

Never check the fuel system while smoking or in the vicinity of an open flame.

CJ5-01

1. Fuel

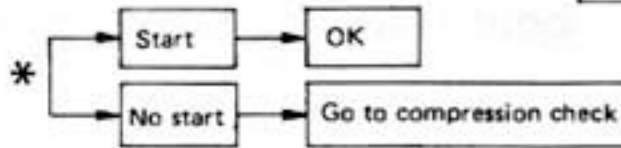
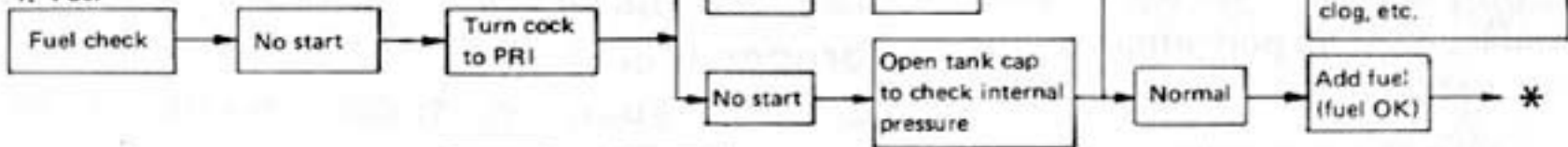

2. Compression

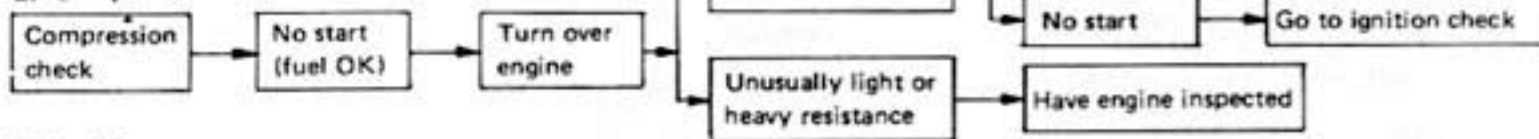

3. Ignition

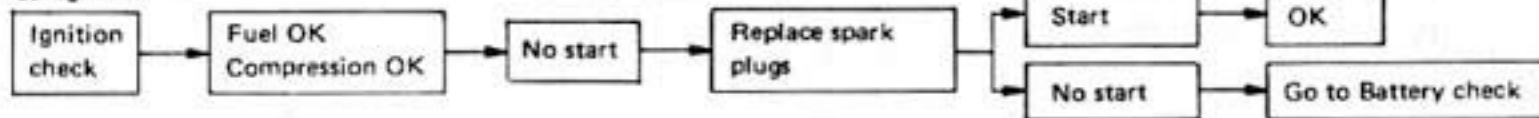

4. Battery

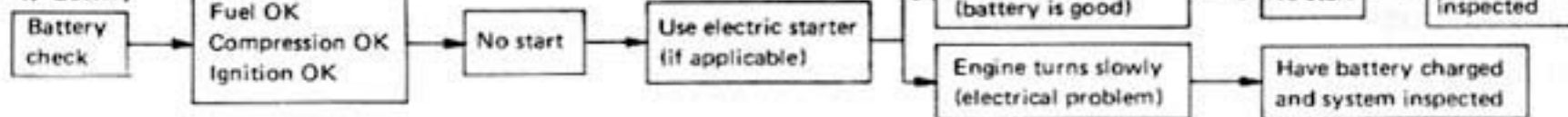

CLEANING AND STORAGE

K-009

A. CLEANING

Frequent thorough cleaning of your motorcycle will not only enhance its appearance but will improve its general performance and extend the useful life of many components.

1. Before cleaning the motorcycle:
 - a. Block off the end of exhaust pipe to prevent water entry; a plastic bag and strong rubber band may be used.
 - b. Make sure the spark plug(s) and all filler caps are properly installed.
2. If the engine case is excessively greasy, apply degreaser with a paint brush. Do not apply degreaser to the chain, sprockets, or wheel axles.
3. Rinse the dirt and degreaser off with a garden hose, use only enough pressure to do the job.

CAUTION:

Excessive hose pressure may cause water seepage and contamination of wheel bearings, front forks, brakes and transmission seals. Many expensive repair bills have resulted from improper high pressure detergent applications such as those available in coin-operated car washers.

4. Once the majority of the dirt has been hosed off, wash all surfaces with warm water and mild, detergent-type soap. An old tooth brush or bottle brush is handy for hard-to-get-to places.
5. Rinse the motorcycle off immediately with clean water and dry all surfaces with a chamois, clean towel, or soft absorbent cloth.
6. Dry the chain and lubricate it to prevent rust.

7. Clean the seat with a vinyl upholstery cleaner to keep the cover pliable and glossy.
8. Automotive-type wax may be applied to all painted and chrome-plated surfaces. Avoid combination cleaner-waxes. Many contain abrasives which may mar the paint or protective finish. When finished, start the engine and let it idle for several minutes.

K-012

B. STORAGE

Long term storage (60 days or more) of your motorcycle will require some preventive procedures to guard against deterioration. After thoroughly cleaning the motorcycle, prepare for storage as follows:

1. Drain the fuel tank, fuel lines, and carburetor float bowl(s).

2. Remove empty fuel tank, pour a cup of SAE 10W30 or 20W40 motor oil in tank, shake the tank to coat the inner surfaces thoroughly and drain off the excess oil. Reinstall the tank.
3. Remove the spark plug, pour about one tablespoon of SAE 10W30 or 20W40 motor oil in the spark plug hole and reinstall the spark plug. Turn the engine over several times (ground spark plug lead wires) to coat the cylinder walls with oil.

U-664

WARNING:

When using the starter motor to crank the engine, remove the spark plug wires, and ground them to prevent sparking.

NOTE: _____

Make any necessary repairs before storing the motorcycle.

4. Remove the drive chain. Thoroughly clean the chain with kerosene and lubricate. Reinstall the chain or store it in a plastic bag (tied to frame for safe-keeping).
5. Lubricate all control cables.
6. Block up the frame to raise both wheels off the ground.
7. Tie a plastic bag over the exhaust pipe outlet to prevent moisture from entering.
8. If storing in a humid or salt-air atmosphere, coat all exposed metal surfaces with a light film of oil. Do not apply oil to any rubber parts or the seat cover.
9. Remove the battery and charge it. Store it in a dry place and recharge it once a month. Do not store the battery in an excessively warm or cold place (less than 0 °C(30 °F) or more than 30 °C(90 °F)).

MISCELLANEOUS

Consumer information

CL0-01

STOPPING DISTANCE

These figures indicate braking performance that can be met or exceeded by the vehicles to which they apply, without locking the wheels, under different conditions of loading and with partial failures of the braking system. The information presented represents results obtainable by skilled drivers under controlled road and vehicle conditions and the information may not be correct under other conditions.

Description of vehicles to which this table applies: Yamaha motorcycle YX600S/YX600SC

A. Fully Operational Service Brake

Load

Light

Maximum

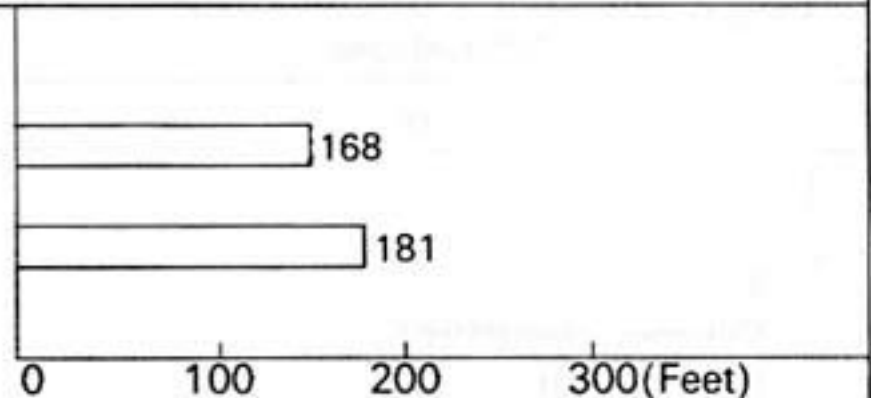

NOTE:

The statement above is required by U.S. Federal law. "Partial failures" of the braking system do not apply to this chart.

Stopping distance in feet from 60 mi/h

SPECIFICATIONS

| Model | YX600S/YX600SC |
|--|--|
| Dimension: Overall length Overall width Overall height Seat height Wheel base Minimum ground clearance | 2,075 mm (81.7 in) 770 mm (30.3 in) 1,095 mm (43.1 in) 765 mm (30.1 in) 1,385 mm (54.5 in) 145 mm (5.7 in) |
| Basic weight: With oil and full fuel tank | 197 kg (434 lb) |
| Minimum turning radius: | 2,400 mm (94.5 in) |
| Engine: Type Model Cylinder arrangement Displacement Bore x Stroke Compression ratio Starting system Lubrication system | Air cooled 4-stroke, gasoline, DOHC 1UJ (YX600S), 1UL (YX600SC) Parallel, 4-cylinder, Forward inclined 599 cm ³ 58.5 x 55.7 mm (2.3 x 2.2 in) 10.0 : 1 Electric starter Wet sump |

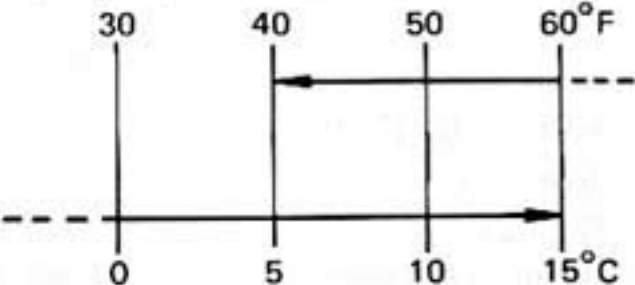
| Model | YX600S/YX600SC |
|---|---|
| <p>Engine oil (4-cycle):</p>  <p>Capacity:</p> <p>Periodic oil change</p> <p>With oil filter replacement</p> <p>Total amount</p> | <p>SAE 20W40 type SE motor oil (If temperature does not go below 5°C/40°F)</p> <p>SAE 10W30 type SE motor oil (If temperature does not go above 15°C/60°F)</p> <p>2.2 L (1.9 Imp qt, 2.3 US qt) 2.5 L (2.2 Imp qt, 2.6 US qt) 2.9 L (2.5 Imp qt, 3.1 US qt)</p> |
| <p>Air filter</p> | <p>Dry type element</p> |
| <p>Fuel:</p> <p>Type</p> <p>Tank capacity</p> <p>Reserve amount</p> | <p>Regular gasoline</p> <p>12 L (2.6 Imp gal, 3.2 US gal) 2.5 L (0.5 Imp gal, 0.7 US gal)</p> |
| <p>Carburetor:</p> <p>Type/Manufacturer</p> | <p>BS30 x 4/MIKUNI</p> |
| <p>Spark plug:</p> <p>Type/Manufacturer</p> <p>Gap</p> | <p>D8EA (NGK) or X24ESU (NIPPON DENSO) 0.6 ~ 0.7 mm (0.024 ~ 0.028 in)</p> |

| Model | YX600S/YX600SC |
|--|--|
| Clutch type: | Wet, multi-disc |
| Transmission: Primary reduction system Primary reduction ratio Secondary reduction system Secondary reduction ratio Transmission type Operation Gear ratio: 1st 2nd 3rd 4th 5th 6th | Chain, Gear 22/21 x 65/28 (2.431) Chain drive 45/16 (2.812) Constant mesh 6-speed Left foot operation 41/15 (2.733) 37/19 (1.947) 34/22 (1.545) 31/25 (1.240) 29/28 (1.035) 27/30 (0.900) |
| Chassis: Frame type Caster angle Trail | Double cradle 27° 128 mm (5.04 in) |

| Model | YX600S/YX600SC |
|--|--|
| Tire: Type Size – Front Rear | Tubeless 110/90-16 59H 130/90-16 67H |
| Brake: Front brake type Operation Rear brake type Operation | Dual, Disk brake Right hand operation Drum brake Right foot operation |
| Suspension: Front Rear | Telescopic fork Swing arm |
| Shock Absorber: Front Rear | Coil spring, Oil damper Coil spring, Oil damper |
| Wheel travel: Front Rear | 140 mm (5.5 in) 98 mm (3.9 in) |

| Model | YX600S/YX600SC |
|---|--|
| Electrical: Ignition system Generator system Battery type/Capacity | TCI AC generator 12N 12A-4A/12V 12AH |
| Headlight type: | Quarz bulb |
| Bulb wattage/Quantity: Headlight Tail/Brake light Flasher light Licence light Meter light | 12V 60W/55W 12V 8W/27W 12V 27W x 4 12V 3.8W x 2 12V 3W x 4 |
| Indicator light wattage/Quantity: "NEUTRAL" "HIGH BEAM" "OIL LEVEL" "TURN" | 12V 3.4W 12V 3.4W 12V 3.4W 12V 3.4W |

WARRANTY INFORMATION

CL0-02

Please refer to your copy of the YAMAHA LIMITED WARRANTY* for details of the warranty offered on your new Yamaha.

The YAMAHA LIMITED WARRANTY contains the warranty policy, an explanation of the warranty, and other important information. Becoming familiar with these policies will help you make the best use of Yamaha's warranty programs.

There are certain requirements which you must meet in order to qualify for warranty coverage **FIRST**, your new Yamaha must be operated and maintained properly, as explained in this manual. If you have any questions about any procedure in this manual, please consult a dealer. **ABUSE AND NEGLECTED MAINTENANCE MAY LEAD TO MECHANICAL FAILURES WHICH CANNOT BE COVERED UNDER WARRANTY.**

SECOND, IF ANY PROBLEMS OCCUR WHICH YOU FEEL SHOULD BE COVERED UNDER WARRANTY, NOTIFY YOUR DEALER IMMEDIATELY. Don't delay, as small problems left unrepaired can become large problems which may not be covered under warranty.

We recommend that the YAMAHA LIMITED WARRANTY be used as a folder in which you may keep your registration and other important documents related to your new Yamaha.

* The YAMAHA LIMITED WARRANTY is to be supplied by a Yamaha dealer at the time of purchase. If you did not receive one, or have lost yours, you may obtain extra copies upon request from your Yamaha dealer or by writing to:

YAMAHA MOTOR CORPORATION U.S.A.

6555 Katella Avenue

P.O. Box 6555

Cypress, California 90630

Attn: Warranty Department

MOTORCYCLE NOISE REGULATION

TAMPERING WITH NOISE CONTROL SYSTEM PROHIBITED:

Federal law prohibits the following acts or the causing thereof: (1) The removal or rendering inoperative by any person other than for purposes of maintenance, repair, or replacement of any device or element of design incorporated into any new vehicle for the purpose of noise control prior to its sale or delivery to the ultimate purchaser or while it is in use or (2) the use of the vehicle after such device or element of design has been removed or rendered inoperative by any person.

“AMONG THOSE ACTS PRESUMED TO CONSTITUTE TAMPERING ARE THE ACTS LISTED BELOW.”

These acts include tampering with the following systems; i.e., modification, removal, etc.

CLO-04

| | |
|----------------|--|
| Exhaust system | Muffler Exhaust pipe Silencer |
| Intake system | Air cleaner case Air cleaner element Intake duct |

MAINTENANCE RECORD

Copies of work orders and/or receipts for parts you purchase and install will be required to document that maintenance has been completed in accordance with the emission warranty. The chart below is printed only as a reminder to you that the maintenance work is required. It is not acceptable proof of maintenance work.

CLO-06

| MAINTENANCE INTERVAL | DATE OF SERVICE | MILEAGE | SERVICING DEALER NAME AND ADDRESS | REMARKS |
|--|-----------------|---------|-----------------------------------|---------|
| 1,000 km or 600 mi or 1 mo. | | | | |
| 7,000 km or 4,400 mi or 7 mo. | | | | |
| 13,000 km or 8,200 mi or 13 mo. | | | | |
| 19,000 km or 12,000 mi or 19 mo. | | | | |
| 25,000 km or 15,800 mi or 25 mo. | | | | |

| MAINTENANCE INTERVAL | DATE OF SERVICE | MILEAGE | SERVICING DEALER NAME AND ADDRESS | REMARKS |
|--|-----------------|---------|-----------------------------------|---------|
| 31,000 km or 19,600 mi or 31 mo. | | | | |
| 37,000 km or 23,400 mi or 37 mo. | | | | |
| 43,000 km or 27,200 mi or 43 mo. | | | | |
| 49,000 km or 31,000 mi or 49 mo. | | | | |
| 55,000 km or 34,800 mi or 55 mo. | | | | |
| 61,000 km or 38,600 mi or 61 mo. | | | | |

– MEMO –

A series of horizontal dotted lines for writing.

YX600S/YX600SC WIRING DIAGRAM

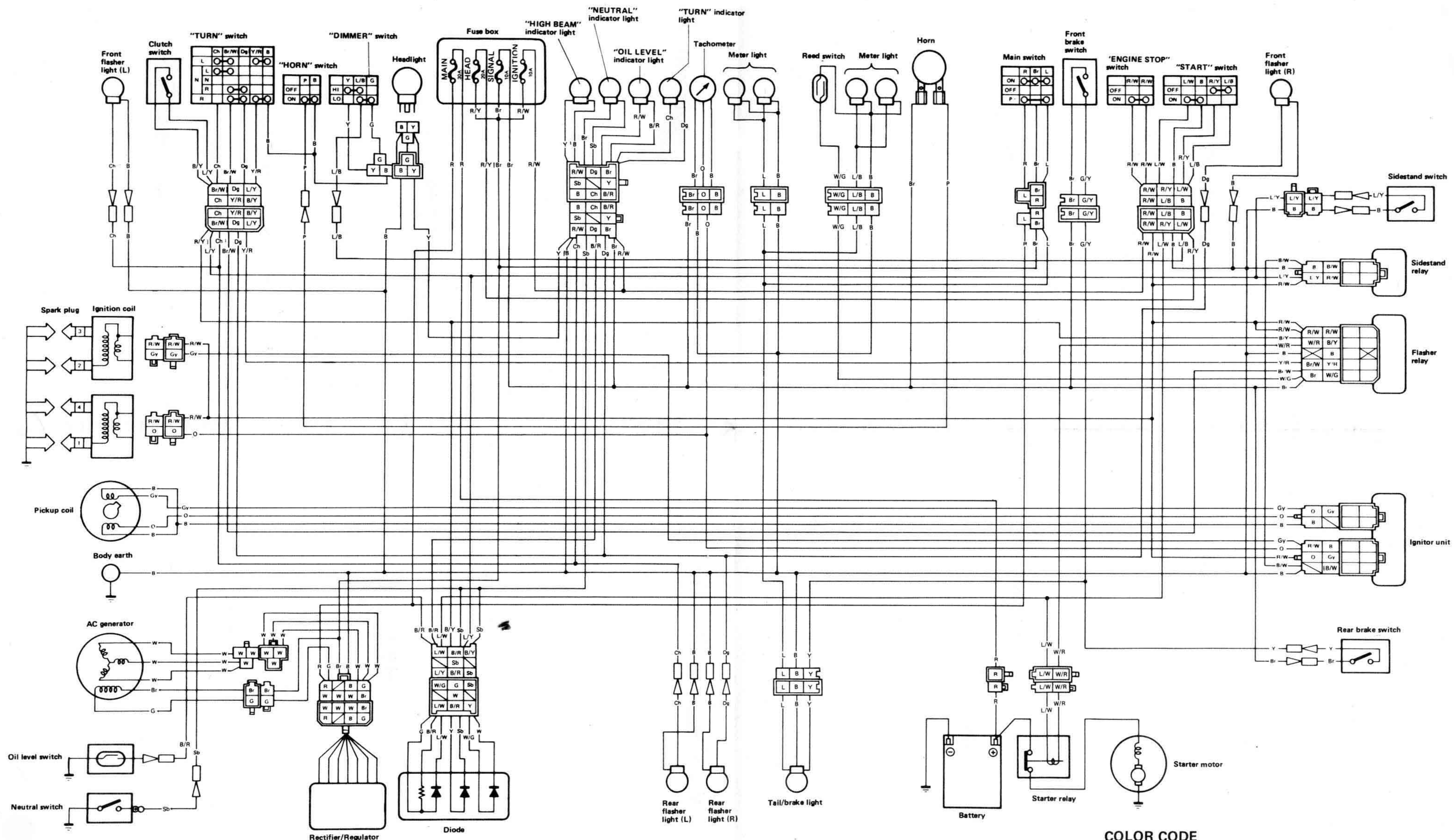

COLOR CODE

| | | | |
|--------------|------------|---------------|--------------|
| B | Black | B/Y | Black/Yellow |
| L | Blue | B/R | Black/Red |
| Y | Yellow | B/W | Black/White |
| O | Orange | L/Y | Blue/Yellow |
| P | Pink | L/B | Blue/Black |
| W | White | L/W | Blue/White |
| G | Green | Y/R | Yellow/Red |
| R | Red | R/Y | Red/Yellow |
| Ch. | Chocolate | R/W | Red/White |
| Dg. | Dark green | R/B | Red/Black |
| Sb. | Sky blue | W/G | White/Green |
| Gy | Gray | | |
| Br. | Brown | | |



YAMAHA MOTOR CO.,LTD.

IWATA, JAPAN

PRINTED IN JAPAN

85 · 11 - 3.91 x 1

(英)

www.badradd600.com